

U.S. DEPARTMENT OF
ENERGY

Office of
**ENERGY EFFICIENCY &
RENEWABLE ENERGY**

Extended Plate and Beam Construction Guide

March 2018





NOTICE

This report was prepared as an account of work sponsored by an agency of the United States government. Neither the United States government nor any agency thereof, nor any of their employees, makes any warranty, express or implied, or assumes any legal liability or responsibility for the accuracy, completeness, or usefulness of any information, apparatus, product, or process disclosed, or represents that its use would not infringe privately owned rights. Reference herein to any specific commercial product, process, or service by trade name, trademark, manufacturer, or otherwise does not necessarily constitute or imply its endorsement, recommendation, or favoring by the United States government or any agency thereof. The views and opinions of authors expressed herein do not necessarily state or reflect those of the United States government or any agency thereof.

Available electronically at Office of Scientific and Technical Information website (www.osti.gov)

Available for a processing fee to U.S. Department of Energy and its contractors, in paper, from:

U.S. Department of Energy
Office of Scientific and Technical Information
P.O. Box 62
Oak Ridge, TN 37831-0062

OSTI www.osti.gov
Phone: 865.576.8401
Fax: 865.576.5728
Email: reports@osti.gov

Available for sale to the public, in paper, from:

U.S. Department of Commerce
National Technical Information Service
5301 Shawnee Road
Alexandria, VA 22312

NTIS www.ntis.gov
Phone: 800.553.6847 or 703.605.6000
Fax: 703.605.6900
Email: orders@ntis.gov



Extended Plate and Beam Construction Guide

Prepared for:

U.S. Department of Energy's Building America Program
Office of Energy Efficiency and Renewable Energy

Prepared by:

Patricia Gunderson and Vladimir Kochkin
Home Innovation Research Labs
400 Prince Georges Blvd.
Upper Marlboro, MD 20774

and

Research Partners:

American Chemistry Council
Dow Building Solutions
Forest Products Laboratory

March 2018

Suggested Citation

Gunderson, P; Kochkin, V. 2018. *Extended Plate and Beam Construction Guide*.
Upper Marlboro, MD: Home Innovation Research Labs. DOE/EE-1730.
www.homeinnovation.com/epbguide2018

This material is based on work supported by the U.S. Department of Energy's Office of Energy Efficiency and Renewable Energy (EERE) within the Building Technologies Office (Award Number EE0007054).

The work presented in this EERE Building America report does not represent performance of any product relative to regulated minimum efficiency requirements.

The laboratory and/or field sites used for this work are not certified rating test facilities. The conditions and methods under which products were characterized for this work differ from standard rating conditions, as described.

Because the methods and conditions differ, the reported results are not comparable to rated product performance and should only be used to estimate performance under the measured conditions.

TABLE OF CONTENTS

EP&B CONSTRUCTION GUIDANCE

EP&B Wall Layout.....	3
Headers.....	4
Framing.....	4
Planning: Insulating Rigid Foam Layer.....	5
Planning: Wood Structural Panel	10
Nailing EP&B Walls.....	11
Window and Door Openings.....	12
Water-Resistive Barrier	13
Rim Band.....	13
Raising Walls	16
Connecting Outside Corners	16
Building Short Walls	17
Quality Assurance: Outside Corners and General	
Air-Sealing.....	18
Quality Assurance: Nailing.....	19
Roof Trusses.....	20
Window Installation	22
Window Flashing.....	22
Sliding Door Installation	24
Hinged Door Installation.....	26
Siding Installation.....	27

EP&B SYSTEM BACKGROUND

1	EP&B System Overview
2	Demonstrating and Optimizing EP&B Walls
6	EP&B Benefits
7	EP&B Thermal Performance
8	EP&B Market Opportunities
9	EP&B Compared to Typical Light-Frame Construction
14	EP&B Sills, Headers, and Rim Headers
15	EP&B Wall Layer Functions
20	Water-Resistive Barriers and Pan-Adhered Flashing
21	EP&B Moisture Considerations
28	EP&B Insulation
29	EP&B Interior Vapor Retarders
30	Installation Specification for EP&B Wall Systems

TERMINOLOGY

c.i.	continuous insulation—generally a rigid or semi-rigid foam or fibrous sheathing material installed exterior to the wall cavity to provide an uninterrupted layer of insulation
ccSPF	closed-cell spray polyurethane foam
CZ	climate zone, as defined by the International Energy Conservation Code
EP&B	extended plate and beam—an advanced wall system developed by Home Innovation Research Labs
FPIS	foam plastic insulating sheathing, made from extruded polystyrene (XPS), expanded polystyrene (EPS), or polyisocyanurate (PIC)
High-R	Building America program reference to wall systems with high thermal resistance exceeding energy code minimum requirements
IECC	International Energy Conservation Code
IRC	International Residential Code for one- and two-family dwellings
o.c.	on center—in wood framing, the measured interval from the center of one thickness of lumber to the next.
OSB	oriented strand board—a manufactured wood panel made of laminated wood fibers, typically available in 4-ft. x 8-ft. sheets in various thicknesses
R-value	quantitative measure of resistance to conductive heat flow ($[\text{hr}\cdot^{\circ}\text{F}\cdot\text{ft}^2]/\text{Btu}$)
WRB	water-resistive barrier—protects the building envelope from liquid water while allowing the diffusion of water vapor back out
WSP	wood structural panel—the layer of wood sheathing (plywood or OSB) that provides shear and racking strength when properly attached to wall framing

EP&B SYSTEM OVERVIEW

Extended Plate and Beam (EP&B) is an advanced wall system developed by Home Innovation Research Labs as part of the Building America Research Program. This innovative configuration has been tested in the lab and in four different demonstration buildings in climate zones 4, 5, and 6.

EP&B is based on tried-and-true lumber construction methodologies, integrating rigid foam sheathing with standard framing practices into a system that preserves many conventional construction features and minimizes builder risk. The EP&B wall system is composed of familiar wall materials but in a different configuration:

- 2x4 studs, with top and bottom plate extensions of 2x6
- 2-in. continuous insulation (c.i.) exterior to the wall cavity, interior to the wood structure panel (WSP)
- More than 95% of the wall area free of thermal bridging
- Common methods and materials for framing, air-sealing, insulation, drainage plane and siding attachment
- Double rim board (beam) that is also a header and is inset to provide space for a c.i. thermal break

This guide contains all the information you need to build a high-performing wall at reasonable cost and effort that meets or exceeds energy code prescriptive insulation requirements for all U.S. climate zones.

- 1 The bottom plate is one dimension larger than the studs.
- 2 The top plates are one dimension larger than the studs.
- 3 There is a layer of rigid insulation in the two-inch space between the stud framing and oriented strand board (OSB) sheathing.
- 4 Rim joist can be inset to provide space for a thermal break of c.i.

Prescriptive requirements for the EP&B wall system will be submitted for inclusion into building codes for the upcoming code development cycle. Until International Residential Code (IRC) approval, use of the EP&B wall system in a specific project must be in accordance with the professional design for that project. The specifications for the EP&B wall system provided in this guide are consistent with the scope of the IRC, save for high-seismic or high-wind areas.

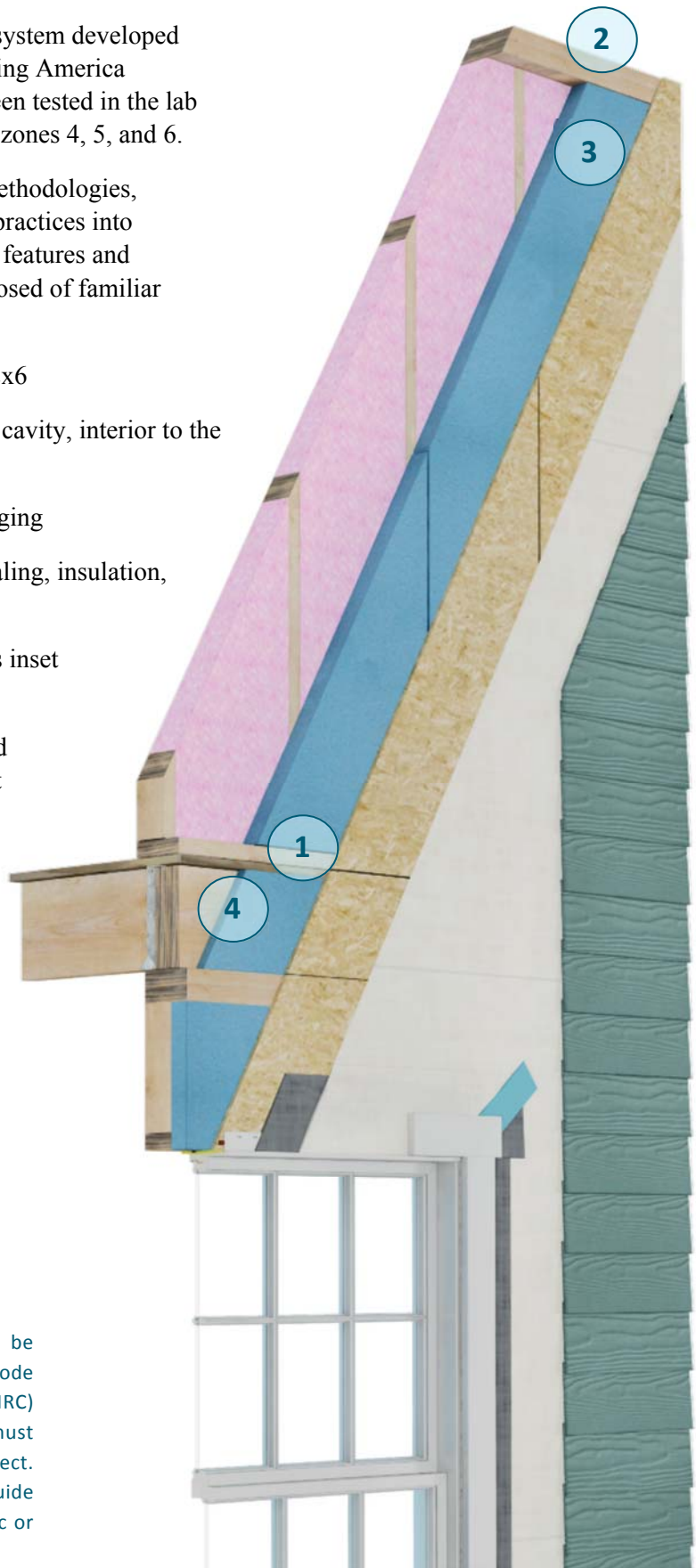

DEMONSTRATING AND OPTIMIZING EP&B WALLS



Kevin L. Smith Construction, from left: Scott, Chad, Kevin, and Josh.



A completed EP&B demonstration home in Grand Rapids, Michigan.



The final recommended EP&B configuration uses two extended top plates, in addition to the extended bottom plate.



Circular saw blades are available for cutting rigid foam, which can reduce foam dust by 95%.
(Photo courtesy Bullet Tools)



A 4+-in. panel pilot bit with a self-driving guide tip and at least 2-3/4-in. cutting depth can simplify cutting window and door openings.
(Photo courtesy CMT USA, Inc.)

The Extended Plate and Beam Wall system has been under development for several years and extensively vetted through research sponsored by the U.S. Department of Energy, the U.S.F.S. Forest Products Laboratory, the New York State Energy Research and Development Authority, and industry sponsors including The American Chemistry Council and Dow Chemical. This guide is the result of a 2015-2017 DOE Building America Research project. The construction photographs are from observation site visits to two different demonstration projects in Grand Rapids, Michigan.

Home Innovation Research Labs extends our thanks to Arn and Kim from McIntyre Builders, Inc., and Kevin, Josh, Scott, and Chad from Kevin L. Smith Construction. These builder partners generously allowed us to document the entire construction process, responded to questions, and provided excellent feedback. As a result of their participation, several modifications were made to the EP&B configuration which will result in reduced complexity, lower cost, and faster build times.

Optimization

The EP&B field tests led to several improvements, which are detailed in this Guide. However, the photographs necessarily show the original, tested configuration. The first design for the EP&B wall extended only two of the three wall plates—the bottom and the second top plate—and used 4-in. nails with a slightly different fastening schedule. While this configuration was strong and minimized thermal bridging due to framing, improvements to complexity and cost were found. The new configuration extends all three plates and uses 3-1/2 in. nails which are readily available, reasonably priced, and fit into almost any nail gun that is currently in a framer’s tool trailer. The WSP fastening follows a sheathing perimeter/field schedule that will be familiar to most framers. Having all plates be the same width reduces confusion on the job site—plates won’t be mistaken for studs. Please keep these improvements in mind as you compare the photos from the field demonstration project to the illustrations, schematics and text in this guide.

Preparation

As a result of the 2-in. layer of foam plastic insulating sheathing (rigid foam), an EP&B wall requires nails that are longer than you may be used to, and a more frequent nailing schedule. Standard nail guns accommodate the 3 -1/2-in. nails, and this fastener can also be used at other framing locations, such as end-nailing studs and joining adjacent studs, which simplifies construction.

Plan on about twice as many nails for WSP attachment than you would normally use. But time and material savings in other aspects mean that an EP&B wall is typically less expensive per square foot and per equivalent R-value, compared to other methods which use rigid foam.

Before beginning, Gather some tools for working with foam – a utility knife, and 3-in. to 6-in. hand blade, a Skilsaw, table saw, and Sawzall. Two-inch foam does not snap cleanly enough for tightly-butted connections, and the field-test crew recommends using non-scored rigid foam if it’s available in your area.

A pilot panel router bit with a self-driving guide tip and at least a 2-3/4-in. cutting length can be a real time-saver, allowing the foam and OSB to be cut in a single pass for openings.

EP&B Wall Layout

The EP&B configuration incorporates plates that are one lumber dimension wider than studs, so keep this in mind when placing the order from the yard. Otherwise, all takeoffs and materials are typical. Because studs and plates are different widths, the EP&B configuration can actually reduce error at the jobsite – pre-cut studs are unlikely to be mistaken for other framing lumber.

EP&B walls have been tested in two framing configurations:

- 2x4 studs with 2x6 plates, yielding a 6-in.-thick wall of R-23 to R-27; and
- 2x6 studs with 2x7.5* plates, yielding an 8-in.-thick wall of R-30 to R-33.

*The asterisk is used to indicate this dimension is actual, rather than nominal.

2x6/2x7.5* can use 16-in on center (o.c.) standard or 24-in. o.c. advanced framing.

Nominal 2x8 lumber is 7.25 in. wide, so a 2x8/2x6 combination does not yield enough gap for 2-in. rigid foam, which is the most readily-available and cost-effective thickness. Home Innovation estimated the costs of various solutions for a higher-R EP&B wall, and found that ripping 2x10s to an actual 7.5-in width is not only the least expensive solution, but rivals the 2x4/2x6 configuration on a per-sf basis, and is nearly 25% less expensive on an R-value basis.

The test crew laid out top and bottom plates along the deck edge, temporarily toe-nailed the bottom plate, then measured and marked the locations of studs, cripples, and openings. If building the 2x4/2x6 EP&B configuration, use 2x6s for this layout. If building a 2x6/2x7.5* configuration, use the 7.5-in. lumber ripped from 2x10s.

Top and bottom plates can be measured and marked together at the deck edge, and then the top plate can be shifted to the middle of the deck to make room for studs and headers. The crew tacked the 2x6 bottom plates to the deck so when they stand the wall up it doesn't slip over the edge. Markings face up and out.

During the planning process, consider how the 2-in. rigid foam sheathing laps at outside and inside corners, and how it affects the construction order, the fastening of the corners, and the integrity of the thermal breaks.

If using an outside corner configuration that has a vertical framing member flush with the exterior plane of the wall, it's handy to orient those on the gable ends of the building, to add bearing capacity below the plates. This is a belt-and-suspenders approach—unlike with walls that have c.i. added to the exterior or those whose only sheathing is rigid foam, there is no need for a doubled truss at each gable end. The WSP is well-nailed to the double, extended top plate supported by typical studs—that combination can easily bear the limited self-load of the truss. The following figures show several acceptable outside corner configurations.



Temporarily nail bottom plate to deck.



Lay out 2x6 top and bottom plates at deck edge; mark stud locations.



Lay out studs and framing lumber according to plan. Remember that in the final recommended EP&B configuration, all three plates should be the same dimension.

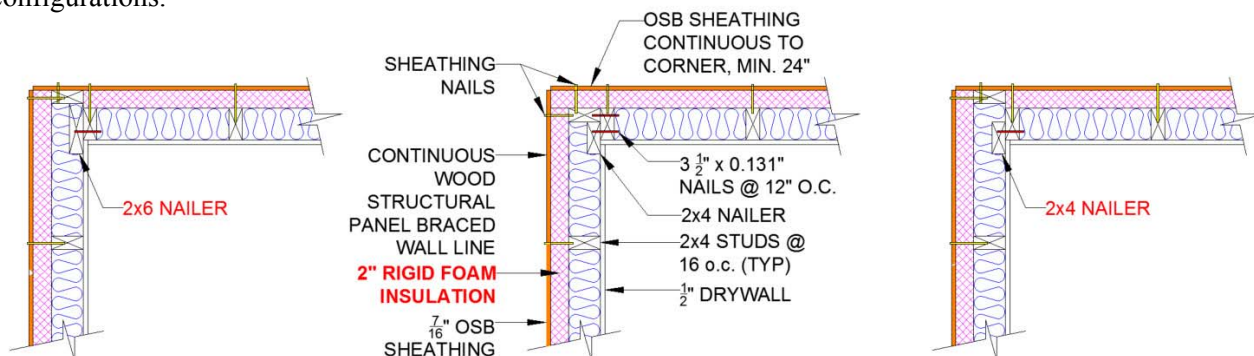



Double headers have a 1-in. foam sandwich; single headers have a 2x4 nailer added at bottom for attaching window trim.

Headers (Where Second-Floor Rim Header is Not Used)

Build headers according to plan. The crew used single hem-fir 1x's where possible, and added a 2x4 at the bottom with a layer of 1-in. rigid foam for nailing window trim. This maximizes space for insulation. They used double hem-fir for larger spans, with 1/2-in. rigid foam sandwiched in between the layers.

Framing

Mark out stud and cripple locations, measure and cut the lumber, and lay out the framing. Lay out studs and headers at the marked locations and cut cripples according to plan.



Move the top plate to the center of the floor deck, lay out studs, and cut a spacer from waste 2x4 to measure for 2-in. rigid foam.

The EP&B wall configuration places the OSB sheathing at the outside plane of the wall, on top of the rigid foam and nailed to the extended plates at top and bottom. Full-width framing is not required at window and door openings. Hinges for swinging doors, and tracks for sliders are coincident with the stud and cripple depth, which bear the horizontal and vertical loads and torque.

The window's framing enclosure can bear on the OSB and span the rigid foam. Nails carry the bulk of the vertical load and the OSB bears the wind load. Full-depth framing can be added if extra strength is desired, but it is not necessary, and it increases thermal bridging due to framing.



Use the spacer when end-nailing studs to measure the gap for the foam layer.

The test crew's typical wall uses let-in bracing and rigid foam as the only sheathing. It's their habit to add a 1x6 sill at window openings to span the wall's width and support the window frame, and they did that in the EP&B test house as well. This is not required but may be preferred.

Lumber often has imperfections and may be twisted or bowed. A uniform gap is necessary for the rigid foam to rest against the studs and still allow the OSB to be attached flush to the face of the plates. The crew made 2-in. spacers out of scrap wood. By holding the spacer at the top of each stud end, flush with the face of the plate, they were able to end-nail each stud and ensure room for the FPIS so the wood sheathing could be nailed flush and flat over the rigid foam.

End-nail the headers and cripples. Lay in corners and nailers for interior partition wall connections. Cut, place, and fasten the 2x6 (or 2x7.25*) second top plate, leaving gaps to tie in the partition wall framing at the top of the wall and to tie corners and adjacent wall sections together.



Position studs and headers according to layout markings on plates. Remember that all plates will be one dimension wider than studs, unlike what is shown here.



End-nail headers and studs. Remember that all plates will be one dimension wider than studs, unlike what is shown here.



Leave gap in top plate for tying-in interior partition walls. Remember that all plates will be one dimension wider than studs, unlike what is shown here.

Planning: Insulating Rigid Foam Layer

A table saw or circular saw is best for vertical cuts (rips) in the rigid foam sheathing that provides the thermal break. Cross-cut the foam to fit between the plates using the table saw; cut to match the full length of the studs. Consider the kerf and ensure that the rigid foam will be snug; 90-degree cuts avoid gapping. Lay the pre-cut rigid foam into place between the top and bottom plates, atop the studs. Don't worry about a small bow in the rigid foam—the OSB will be stiff enough to overcome that, once it is nailed on.

Behind headers and cripples, take advantage of scrap foam pieces, and tack them into place with a few cap nails. All rigid foam joints should land on studs.

In the EP&B configuration, the foam sheathing installed on the interior side of the OSB provides a distinct, centrally-located vapor control plane with effective drying to the direction where the source moisture came from – exterior to the exterior and interior to the interior. To ensure this layer is uninterrupted, use manufacturer-approved tape (such as DOW Weathermate™) to seal all seams between rigid foam panels and where they meet framing at the top and bottom plates. Check the spec sheet to make sure the tape is approved for use on wood. A single line of 2-7/8-in. tape at the top of the wall can seal both the foam/plate connection and the plate/plate connection. Taping the seams adds a level of protection where interior vapor drive is higher, such as winter conditions in CZs 6, 7, and 8. Fully detailed taping also allows the rigid foam layer to serve as the air barrier.

Precutting lengths of rigid foam is preferred, but if you do have to trim foam in place next to an extended plate, be sure to adjust the guide plate of the circular saw to ensure you do not cut into the lumber below.

ALTERNATE: If you do not have a table saw on site, you can use a circular saw to cut the rigid foam sheathing in place atop the walls. Lay the foam onto the wall, snugged to the bottom plate and overlapping the top plates. Use a few cap nails to hold the FPIS in place, then snap a chalk line along the top edge coincident with the bottom of the first top plate. Use a circular saw to cut away the excess foam. Take care to set the guide plate for 2-in. depth and seat the guide of the saw flat against the foam's surface for a square cut to ensure a snug fit when the foam is pressed into place between the plates and against the studs.

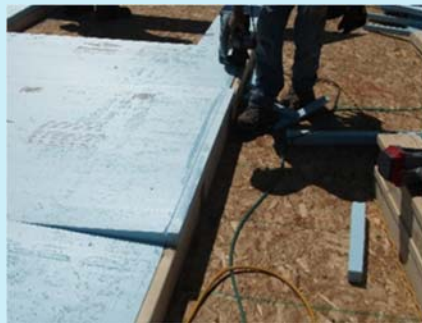

A table saw trims 2-in. rigid foam cleanly, with little waste or debris.



Measure and cut rigid foam for a snug fit between the EP&B wall's top and bottom plates.



Cap nails can keep the rigid foam in place until the OSB is fastened over the top.



Adjust the height of the circular saw blade to protect the framing.

EP&B BENEFITS

Wood Sheathing over the Rigid Foam Layer Allows for Standard Installation Approaches

The EP&B system locates the structural sheathing exterior to the foam sheathing. Windows, doors, the drainage plane, and the water-resistive barrier (WRB) are all located as in standard frame wall systems with well-known installation methods.

The EP&B wall system achieves more than 95% c.i. without adding complexity or risk, to yield the following advantages:

- Has a clearly identified location for the drainage plane and uses standard WRB installation;
- Allows windows and doors to be installed as in typical framing;
- Keeps the cavity warmer because of the foam’s relative thickness and its location in the assembly;
- Slows interior moisture movement to the OSB or other structural sheathing;
- Promotes cavity drying to the interior and wood sheathing drying to the exterior; and
- Lab tests confirm good structural performance.



Typical location of rigid foam: exterior to WSP

Problem Solver

Typically, rigid foam c.i. located in the traditional location exterior to the structural sheathing requires special attachment of windows, doors, and siding. Thickness in excess of 1-in. may require additional furring and support for windows and doors, as well. Depending on the type of cladding, the IRC may require continuous backing, which would necessitate a 1/2 in. foam fill layer between furring strips. This ordering also complicates decisions about the location of the drainage plane and WRB—complications that are avoided with the EP&B system.

EP&B location of rigid foam: interior to WSP to simplify installation of windows and siding

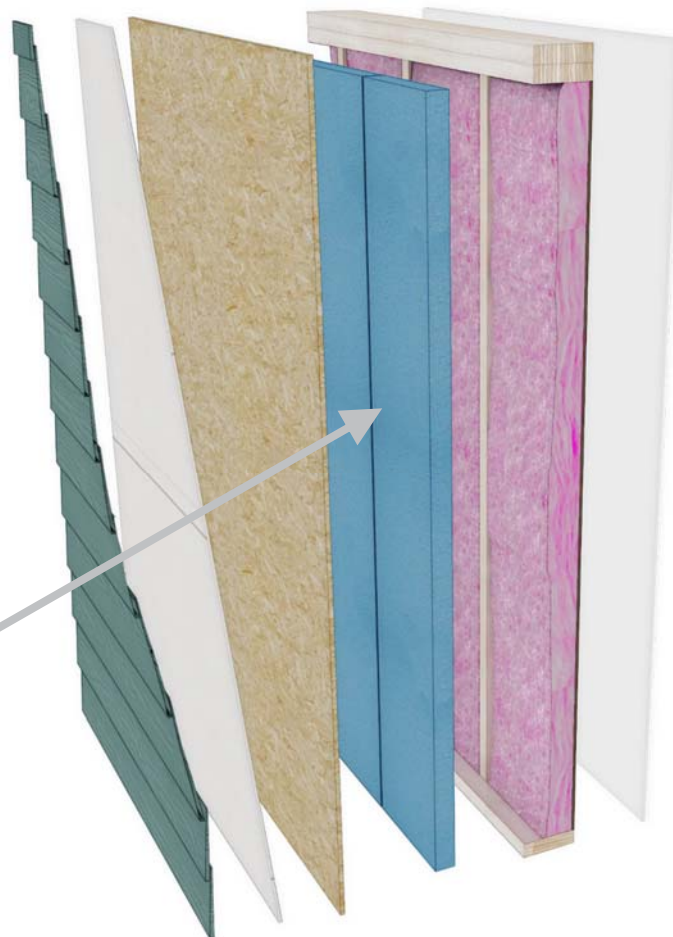

EP&B THERMAL PERFORMANCE

Light-Frame Wall Performance—Walls with a 2 in. layer of exterior c.i. provide improved performance.

Light Frame Wall System ^a	Wall Thickness ^b	R-Value Nominal ^c	U-Value Calculated ^d	Wall Area % by Thermal Path			
				Cavity only	Cavity/c.i.	Lumber/c.i.	Lumber (bridge)
2x4 Standard 16 in. o.c. R13	4 in.	13	0.0840	75%	n/a	n/a	25%
2x6 Standard 16 in. o.c. R20	6 in.	20	0.0595	75%	n/a	n/a	25%
2x6 Advanced 24 in. o.c. R20	6 in.	20	0.0535	85%	n/a	n/a	15%
2x4 Std 16 in o.c. R13 + R10 ^e	6 in.	23	0.0459	0%	75%	25%	0%
2x4 Std 16 in o.c. R13 + R10 ^f	6 in.	23	0.0441	0%	75%	25%	0%
2x4/2x6 EP&B R13 + R10	6 in.	23	0.0461	0%	75%	20%	5%^h
2x6/2x7.5* EP&B R21 + R10^g	8 in.	31	0.0344	0%	85%	10%	5%^h

^a Vinyl siding, house wrap, #2 SPF lumber, 1/2 in. OSB, 1/2 in. gypsum drywall

^b Wall framing, sheathing, and furring

^c R-value in hr·°F·ft²/Btu; includes cavity and c.i. values

^d U-value in Btu/(hr·°F·ft²); includes all layers, interior/exterior finishes and film factors; calculated using ASHRAE Parallel Path method

^e One layer of 1.5-in. rigid foam, with 1/2 in. foam layer alternating with let-in furring strips at 16-in. intervals

^f One layer of 2-in. rigid foam, with 1x4 surface-mounted furring strips at 16-in. intervals

^g 24-in. o.c. advanced framing

^h Using an inset rim beam with a layer of c.i.

Note: All exterior c.i. examples use extruded polystyrene (XPS)

EP&B Walls Meet or Exceed Energy Code Requirements in All Climate Zones

The basic EP&B wall system using 2x4 studs and 2x6 plates meets or exceeds the most stringent IECC prescriptive insulation requirements for above-grade walls in all U.S. CZs.

Compared to an IECC code-minimum prescriptive wall, the typical 2x4/2x6 EP&B wall offers an 82% improvement in CZ 1 and 2, and a 25% improvement in CZ 3, 4, and 5, when compared using the calculated whole-wall thermal performance. EP&B provides nearly the same whole-wall performance as the prescriptive wall in CZs 6 through 8, with less cost and complexity.

The extended plates constitute only a 4.4% thermal bridge. This reduces performance by about R-1 compared to 100% exterior c.i., but with practical benefits that many builders find compelling.

For next-level performance, the EP&B configuration can be adapted to 2x6 stud framing, using a true 7.5 in. plate by ripping 2x10's to allow for the 2 in. layer of c.i. This configuration achieves nearly a 30% assembly R-value increase over the calculated performance of IECC prescriptive minimum walls in the coldest climates.

EP&B walls can contribute to whole-building thermal performance to help qualify for voluntary energy certification programs such as National Green Building Standard (NGBS), Leadership in Energy Efficient Design (LEED), and ENERGY STAR® for Homes.

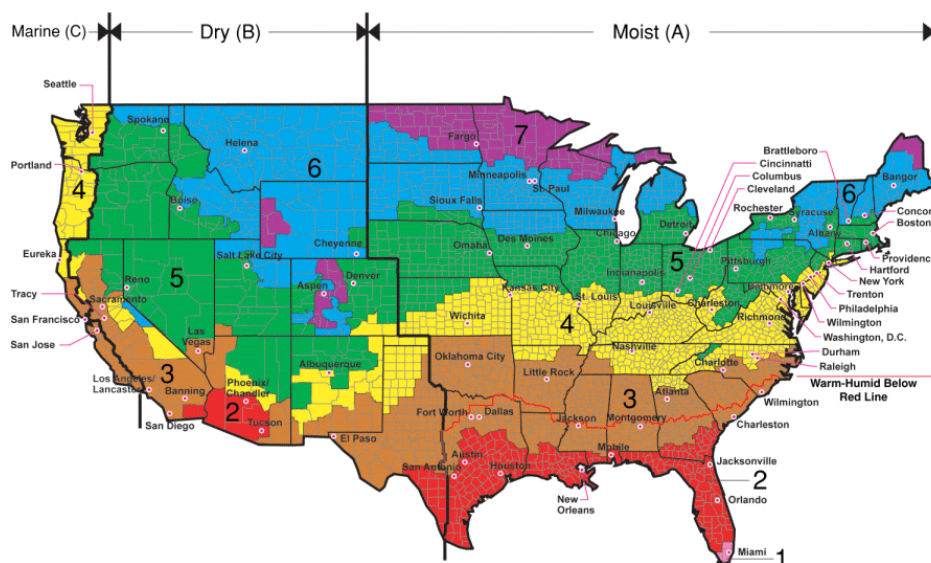

All of Alaska in Zone 7 except for the following Boroughs in Zone 8: Bethel, Dellingham, Fairbanks, N. Star, Nome North Slope, Northwest Arctic, Southeast Fairbanks, Wade Hampton, and Yukon-Koyukuk

Zone 1 includes: Hawaii, Guam, Puerto Rico, and the Virgin Islands

DOE CZ map

EP&B MARKET OPPORTUNITIES

Flexibility

The EP&B method launches directly from the starting point most comfortable for residential builders today: 2x4 light framing. The technique is innovative; however, the system is non-proprietary—builders can choose from a broad variety of sheathing, rigid foam, WRB, and cavity insulation options, and the system is readily adaptable to field modifications.

Maintenance & Comfort

The EP&B wall’s nearly continuous 2-in. layer of rigid foam ensures a warm cavity and reduces the potential for condensation and resultant mold growth. Dryer wall assemblies also contribute to greater durability and longevity of materials, which reduces maintenance cost and effort. Additionally, higher R-value means a warmer interior surface in the occupied space, which improves occupant comfort.

Can Be Panelized & Shipped

Often builders choose to have wall components factory-fabricated to streamline the construction process. Many high-performing walls do not lend themselves to factory panelization, either due to their complexity or to the risk of damage in shipping. The EP&B system design requires modest changes to the panelization process, but once employed, panels can be easily constructed and shipped from the factory to the worksite. The structural sheathing effectively protects the foam sheathing from damage during transport.

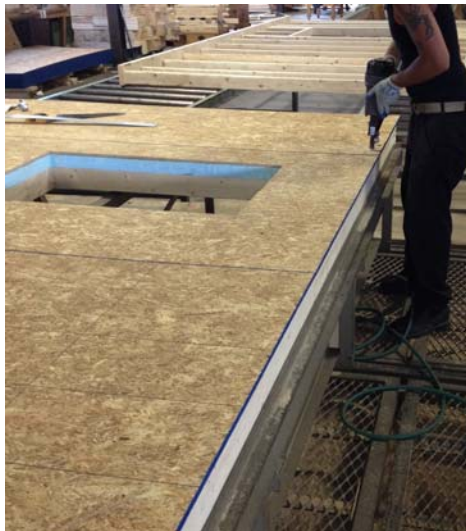

Factory Panelization—EP&B Walls can be factory fabricated.



Factory Panelization—Bundling and strapping panels.



Factory Panelization—Loading and shipping panelized wall sections from the factory.



Factory Panelization—EP&B wall system allows the contractor to realize scalar and waste reduction savings.



EP&B Wall Panel Erection—Note top plate end gap and sheathing overlap to tie into the neighboring panel.

EP&B COMPARED TO TYPICAL LIGHT-FRAME CONSTRUCTION

Competitive Cost

The EP&B system offers good value and reduced risk in the transition to high-R, high-performing walls. In the following graph, R-value (dark blue bar) and cost per sf of wall (light blue bar) are measured on the left axis. On a unit-area basis EP&B costs the same or less than an IECC prescriptive 2x4 wall with 2 in. of c.i., with arguably less complexity. For a typical 1,800-ft² single-story home, that difference can translate to several hundred dollars. When measured by the cost of the R-value provided per square foot of wall (right axis and yellow trendline), the 2x6/2x7.5* EP&B configuration meets or beats all competitors.

Advantages of Continuous Exterior Insulation

For decades, high-performance builders have used rigid insulation installed to the exterior of the wall sheathing (and sometimes replacing the sheathing) to increase thermal performance. This method effectively eliminates thermal bypass (or short circuits) caused by the framing—essentially covering nearly 100% of the framing geometry with a continuous layer of insulation.

In addition to improving thermal performance, the rigid foam c.i. can potentially reduce air infiltration and improve moisture performance. But rigid foam as the exterior layer of a wall also impacts installation details, including window load transfer and flashing, drainage plane and vapor barrier considerations, and siding attachment methods.

Although there is a long history of exterior insulation use, material selection and detailing requirements can still be challenging for many builders. The EP&B system provides an alternate, straightforward approach to incorporating c.i., especially compared with wall systems that require additional furring for siding installation.



Interior view of EP&B wall system.



Exterior view of EP&B wall system.

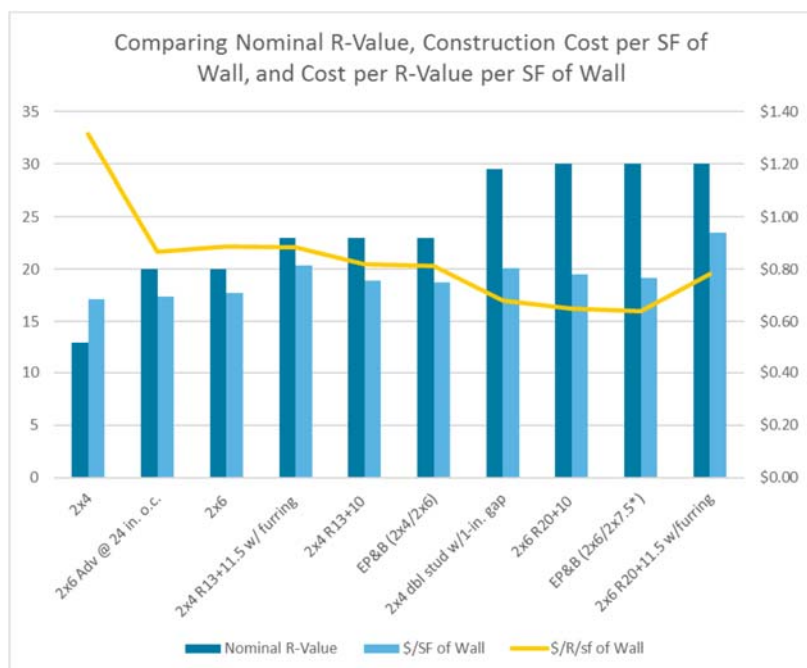

Left, Cost Comparison: EP&B walls provide excellent incremental thermal and construction cost value. (16-in. o.c. framing unless otherwise noted.)

Note: Home Innovation Research Labs performed cost comparisons in 2015 for a typical 200-ft² residential wall with all components including windows and siding and rim beam. The comparison cost estimates for 2x4 and 2x6 walls with 2 in. of c.i. exterior foam include taped foam panel joints to perform as the WRB. The EP&B wall cost estimate includes a separate WRB.

Planning: Wood Structural Panel



OSB sheathing must always be oriented vertically, for structural bracing.

For required structural bracing to match the performance of an IRC prescriptive wall*, use plywood or oriented strand board (OSB) between 3/8-in. and 15/32-in. The wood structural panel (WSP) in an EP&B wall must always be oriented vertically—no horizontal joints are allowed. All WSP and rigid foam joints must occur at studs, but not at the same stud – plan your sheet placement to avoid the occurrence of a WSP seam at the same stud where two sheets of rigid foam meet. Butt rigid foam joints tightly together, but provide the typical 1/8-in. gap when installing WSP (a 10d box nail works great) or as required by code or manufacturer’s installation instructions.

When building a single long wall in two sections that will be attached once the walls are tipped up, plan for the overlap of the rigid foam and WSP, to maintain the staggered vertical joints (two photos, bottom left).

For the first two walls, generally the long walls at opposite sides of the building, you can fully complete all wall layers (including rigid foam and OSB) while the wall is laying flat on the floor deck. When building the perpendicular short walls, plan your outside corners to maintain the thermal break, which probably means leaving some gaps in both the rigid foam and the OSB, to be filled in after the wall is erected.



Two adjacent sections of wall must be planned to stagger the vertical joints of the rigid foam and OSB.

Plan your cheat: if the pre-cut studs are at 92-5/8 in., the raw wall height with three 2x plates will be 97-1/8 in. A 4x8 sheet of OSB or plywood is 95-7/8 in. x 47-7/8 in., which makes it 1-1/4 in. short. You can apply that entire gap at the top and fasten to the first top plate (rather than the second top plate) for structural bracing, or you can split the difference by leaving a 5/8-in. gap at both top and bottom.

*See bottom of page 1 for usage recommendations. Structural lab testing based on AC 269.1 indicates the EP&B wall performs as well or better than a prescriptive WSP braced wall.



Two adjacent sections of wall must be planned to stagger the vertical joints of the rigid foam and OSB.

ALTERNATE: A third option for OSB installation is to do what the Grand Rapids framing crew did. The first-floor rim was 10 in. engineered lumber inset from the outside plane to accommodate 1 in. of c.i. To simplify air-sealing at the rim band, our crew designed the walls so that the OSB would lap the sole plate and extend down across the rim; this required using 9 ft. OSB and some care during tip-up.

See page 13 for rim band options. In this case, the bracing connection was still made by nailing with 3-in. o.c. spacing to the sole plate, and the bottom edge of the OSB was nailed through the foam to the rim at 6-in. o.c. spacing. A ripper was added at the bottom for a seamless exterior sheathing surface to accept cladding. If the wall height allows the sheathing to extend all the way to the sill plate, that location can become the bracing connection with 3-in. o.c. nailing.



Nailing EP&B Walls

Due to the added thickness of the rigid foam, an EP&B wall requires longer-than-typical nails and a modified nailing schedule. Most standard nail guns marketed for residential framing can accommodate the 3-1/2-in. nails. You will probably be familiar with the perimeter/field pattern from typical stapling schedules, but for EP&B it is doubled: 3-in./6-in. instead of 6-in./12-in. Please note that staples are not an approved substitute for nails in the EP&B wall configuration.

Where two sheets of OSB meet in typical light-framed walls with wood structural panels (WSPs), nails are shot at a slight angle to maintain the necessary setback from the panel edge.

The typical angle for attaching structural sheathing directly to a light-framed wall is too steep for EP&B because of the 2-in. layer of rigid foam. It is necessary to straighten the angle so the nail does not over-reach and “blow past” the opposite side of the stud.

Full fastener engagement at the specified frequency is required for the wall to meet the IRC bracing requirements. The nail gun does not give any indication of whether the nail has sunk entirely into the sheathing or has driven through and past the lumber. You’ll have to examine this after the wall is standing. From inside the wall, you can use your hand to push the foam near the stud to test the connection.

This level of quality assurance is necessary with any WSP-braced wall that is built on the floor deck and subsequently tipped into place.

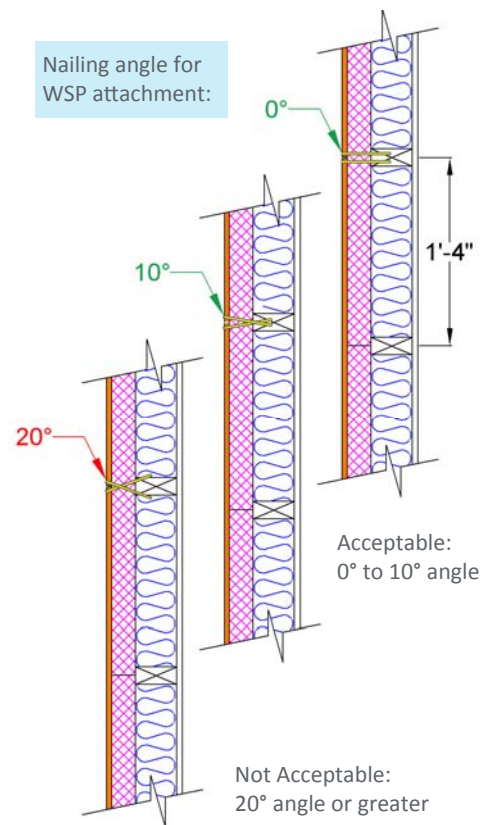

ABOVE, plan view: Correct nail gun angle achieves full fastener engagement at wood sheathing joints. If vertically staggered, nails can be angled up to 10 degrees. Angles of 20 degrees and more will cause the nail to blow past the stud on the opposite side, weakening the wall and requiring re-nailing from the exterior once the wall has been tipped into place.

LEFT, EP&B wall panel: 3-1/2-in. nails at 3-in. spacing at panel edges, 6-in. spacing for the field (3/6 perimeter/field pattern). See page 13 for rim insulation strategies.

EP&B Connection Schedule*

Connection	Fasteners	Schedule
EP&B Perimeter of Sheathing	3.5 in. x 0.131 in. (framing nail gun for EP&B)	3 in. o.c.
EP&B Field of Sheathing	3.5 in. x 0.131 in. (framing nail gun for EP&B)	6 in. o.c.
Top Plate to Top Plate (face-nail)	10d box (nail gun: 3.5 in. x 0.131 in.)	12 in. o.c.
Top/Bottom Plate to Stud (end-nail)	16d box or 10d box (nail gun: 3.5 in. x 0.131 in.)	Three per stud
Stud-to-Stud -Braced Wall Panels (face-nail)	16d box (nail gun: 3.5 in. x 0.131 in.)	12 in. o.c.
Corner studs in direct contact with each other	16d box (nail gun: 3.5 in. x 0.131 in.)	12 in. o.c.
Corners: WSP from both intersecting walls nailed directly to a common 2x framing member	2.5 in. x 0.131 in. nails (nail gun: 3.5 in. x 0.131 in.)	6 in. o.c.
Corner studs separated by up to 2 in. of rigid foam sheathing insulation, two options	5 in. x 0.135 in. nails 6 in. x 0.190 in. structural insulated panel screws	6 in. o.c. 12 in. o.c.

*Notes: Staples are NOT an acceptable substitute for nails in the EP&B wall system. Table identifies potential opportunities () to substitute with the 3.5-in. nail required for EP&B sheathing attachment, for economy of time.

Table adapted from IRC Table R602.3(1). This table does not supersede local code requirements for general framing and fastening.

Window and Door Openings

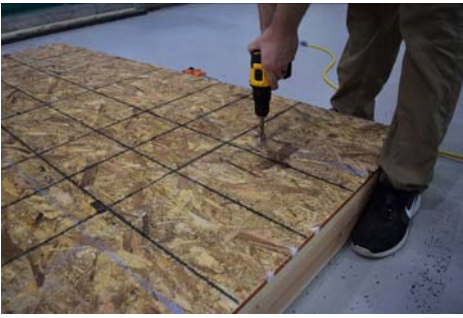

Snap chalk lines and drill holes.



Sink the circular saw to catch the first drill hole. Do not overcut at corners.

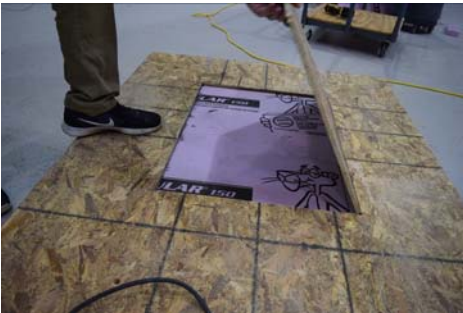

Remove OSB.



Cut corners of remaining rigid foam with a hand blade or reciprocating saw.



Remove the foam from the opening.

Removing both the rigid foam and the OSB in a single operation is the preferred method, saving time and effort. Double check that your penciled notes for window and door openings will still be visible on the top face of the second top plate once the OSB is placed and nailed. Lay the OSB over the rigid foam and attach with 3-1/2-in. nails at the 3/6 schedule. Economize by using foam scraps at header and cripple locations. Snap chalk lines at all vertical and horizontal opening edges.

CIRCULAR SAW: The cleanest cuts with the least debris will be made with a circular saw. A 7-1/4-in. blade is required to cut the full depth of the 2-in. rigid foam and the 7/16-in. OSB. Drill all four corners and snap chalk lines. Start the saw a few inches from the drilled corner and sink the blade into the OSB. Follow the chalk line on all four sides. Cut the OSB all the way to the drilled corner, but do not overcut—the short sections of rigid foam in each corner can be removed later with the 4-in. blade or a reciprocating saw. Follow similar steps if using a track saw.

ROUTER: Use a 4-in. (or longer) pilot panel bit with a self-driving tip and a cutting depth (flute) of at least 2-3/4 in. Punch through each opening near a corner and use the 2x framing below the rigid foam as a guide. A long bit with a solid guide head is necessary to reach the full depth and seat against the 2x4 so the path will be true. A router creates more debris than a circular saw.

ALTERNATE: Two Separate Steps. Cut the rigid foam in place first with a reciprocating saw, and then lay in the OSB and make a second pass with the circular saw. This is more time-consuming, but has the advantage of providing some limited view of the framing, and is thus more forgiving. With practice, this can be done with very little time taken for measurement.

Once the rigid foam is in place and before laying in the OSB, cut the openings out of the foam with the reciprocating saw. Use the 2x4 framing to guide the saw's path—this is done both by eye and by feel. Although the cut is not crisp, it's clean enough to provide a good connection to the wood framing if you keep the blade perpendicular and don't remove too much material. Initially, you'll guide the saw along the 2x4 by feel. Once the foam rectangle is removed from the opening, you may need to tidy up some edges. Then lay in and nail on the OSB, and snap your chalk lines. Use a circular saw set to 1/2-in. depth. Having already removed the rigid foam, once the first opening is made by the circular saw, you'll be able to see the 2x4 framing below and use that as an additional visual guide.



Use the 2x4 framing to guide the reciprocating saw to cut out FPIS.



Sweep away debris and lay in OSB, careful to stagger joints vs foam.



Nail OSB at top and bottom plates and use circular saw to cut OSB at opening.

Water-Resistive Barrier

Attach and detail the water-resistive barrier (WRB) when all openings have been cut, both top plates are nailed on and the OSB is attached per the EP&B Fastener Schedule. Fold back the WRB from wall edges and tack it temporarily.



Attach WRB before wall erection to save time and effort. Use cap nails or wide staples per manufacturer's requirements.



Cut window openings. See window installation and detailing guidance on page 22.



Staple WRB into place. Fold back and tack long edges that need to wrap down or around when the wall is later tipped up.

Rim Band

Lab tests confirm good structural performance with a double rim located at the exterior plane. Insetting a single or double rim by 1 in. also meets IRC performance targets in lab tests, and improves thermal performance by making room for a continuous layer of rigid foam. A final option allows a 2-in. inset if the WSP spans the entire wall/rim assembly, and the scheduled fasteners connect the bottom OSB edge to the sill plate. See illustrations at the bottom of this page.

If you intend to add c.i. to the rim, now is the time. The Grand Rapids demonstration crew used 1-in. rigid foam and made sure the thermal break was continuous at corners.



Cut rigid foam for rim.



Tack c.i. rigid foam to rim band.



Ensure a complete thermal break.

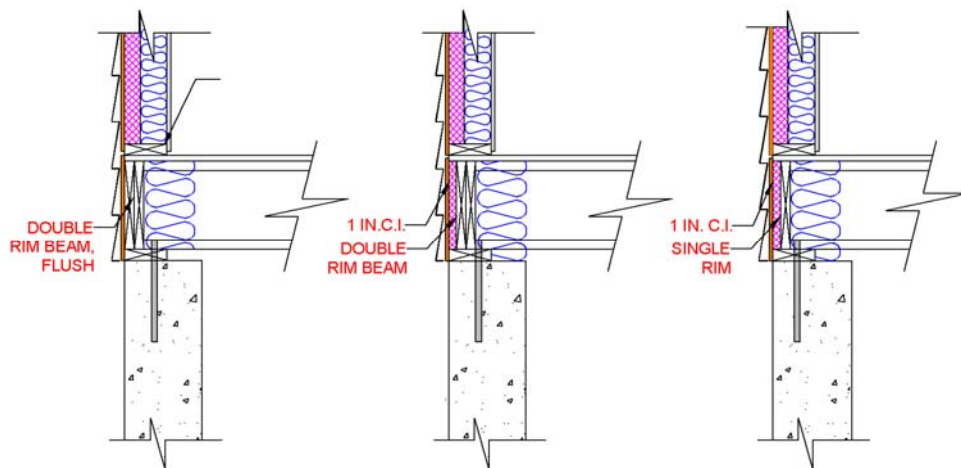

Rim Options – Double Rim joists may be flush to the exterior of the wall or inset by 1 in. to accommodate rigid foam layer. A single rim joist must be inset by 1 in.

NOTE: A single rim board must be not sufficiently strong to perform the duty of a header. In this case, utilize typical headers of solid or laminated lumber.

NOTE: Insetting the rim by 2 in. is allowed only if the full length of the WSP spans the entire rim height and is fastened to the sill plate per the EP&B nailing schedule.

EP&B SILLS, HEADERS, AND RIM HEADERS



Double Rim Beam as header; note joist hangers and caulk sealing.

The EP&B wall design can use single rim joists for non-load-bearing walls with no openings, and typical headers. For two-story buildings, a double rim can act as the header for openings below and provide ample bearing for the floor joists. The joists above the opening will require joist hangers. Use of double rim headers is cost-effective and can stream-line the wall installation and allow the c.i. to span more wall area, reducing framing short-circuits. Windows can be installed in the EP&B wall with no special modifications. A 1x6 sill is sometimes added for convenience, but not required.



1x6 sill added (not required).



Double header.



Single header, with 2x4 nailer.

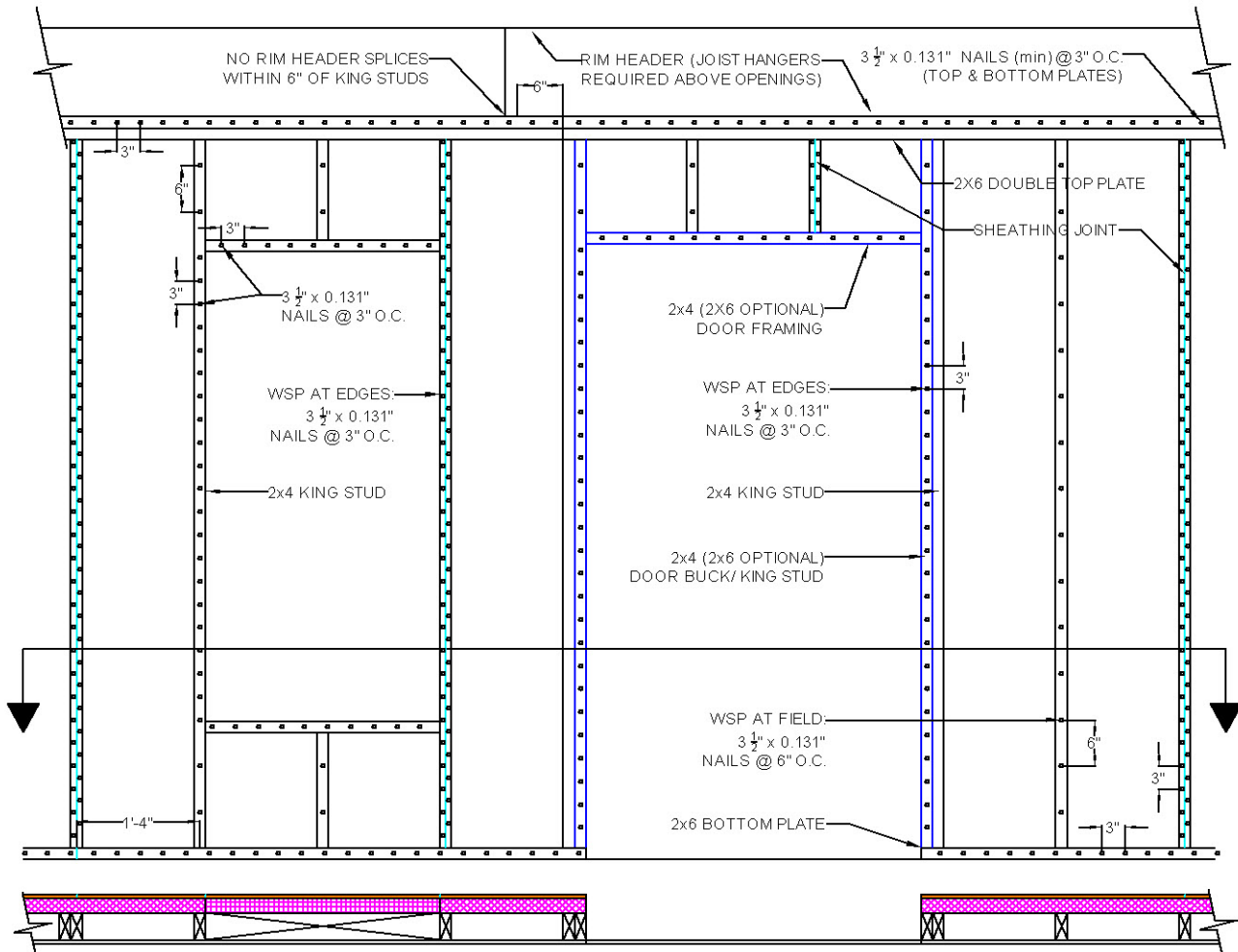

EP&B Wall Elevation – Joists attached to the double rim beam above wall openings require joist hangers. Use 3-in. nail spacing for all edges of wood sheathing panels, including at openings. No rim header splices are allowed within 6 in. of king studs.

EP&B WALL LAYER FUNCTIONS

Right: EP&B Wall Detail (first-floor bottom plate detail not shown).

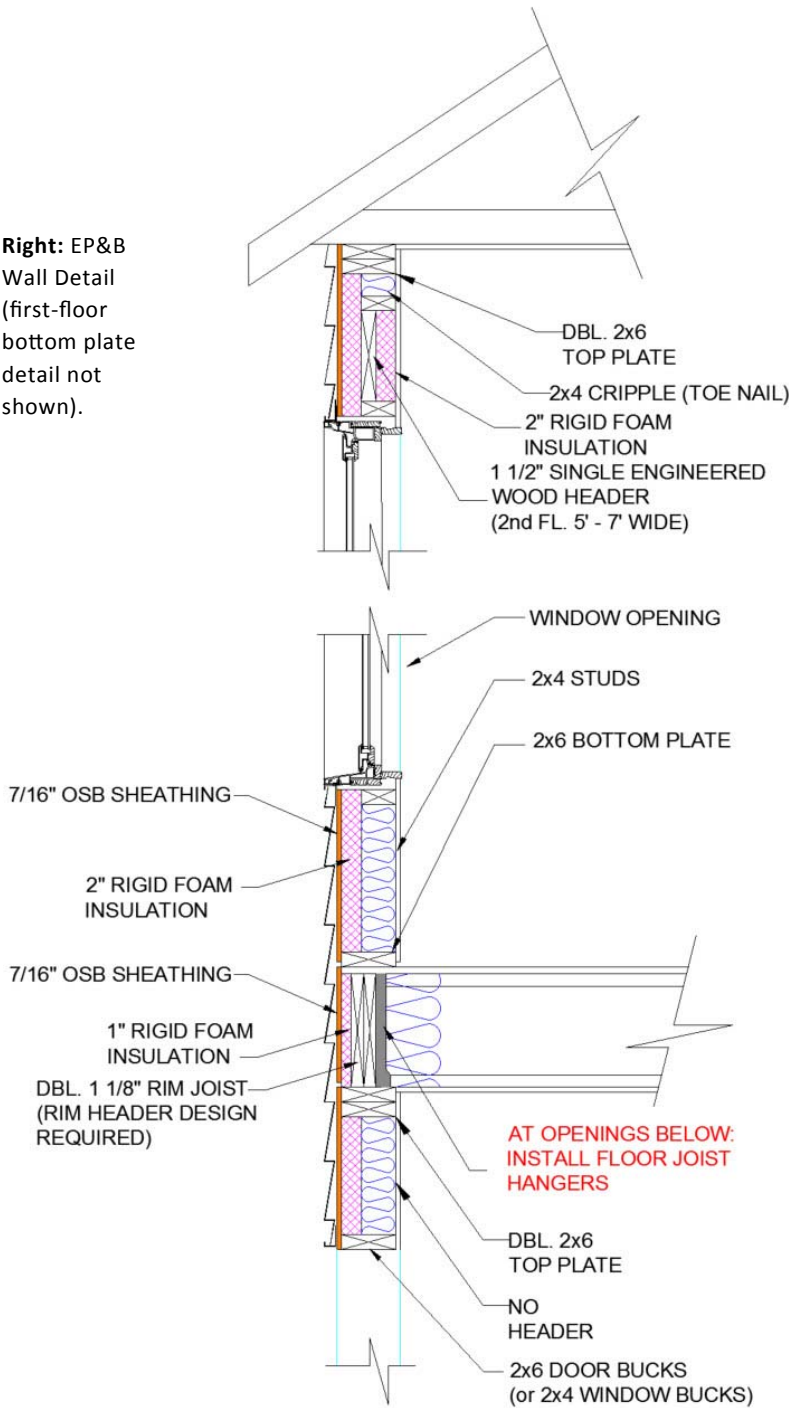

The EP&B wall system detail at left is summarized for a 2-story house design (the WRB layer is not shown). EP&B unique characteristics include:

- Extended plates provide a 2-in. space for the rigid foam layer;
- Windows are framed with 2x4 framing, reducing thermal bridging;
- Doors are framed with either 2x4s (typical) or 2x6s (heavy-duty);
- Structural wood sheathing is attached directly to the extended plates, for shear resistance;
- Structural wood sheathing is detailed as the air barrier, as with typical light-framed walls;
- Double rim provides load transfer between floors;
- Double rim can act as a header for the openings below (joist hangers required);
- Double rim can be inset up to 2 in. to accommodate rigid foam c.i.; and
- A single header is used for many openings in the second floor to maximize insulation.

Lab tests confirm good structural performance with the rim located at the exterior plane, using the nailing schedule described in this guide.

Insetting a double or single rim by 1 in. also meets IRC performance targets in lab tests, and improves thermal performance by making room for a c.i. layer of rigid foam. A final option allows a 2 in. inset if the WSP spans the entire wall/rim assembly, and the scheduled fasteners connect to the sill plate.

Note that a single rim board is not sufficiently strong to perform the duty of a header. In this case, utilize typical headers of solid or manufactured lumber.

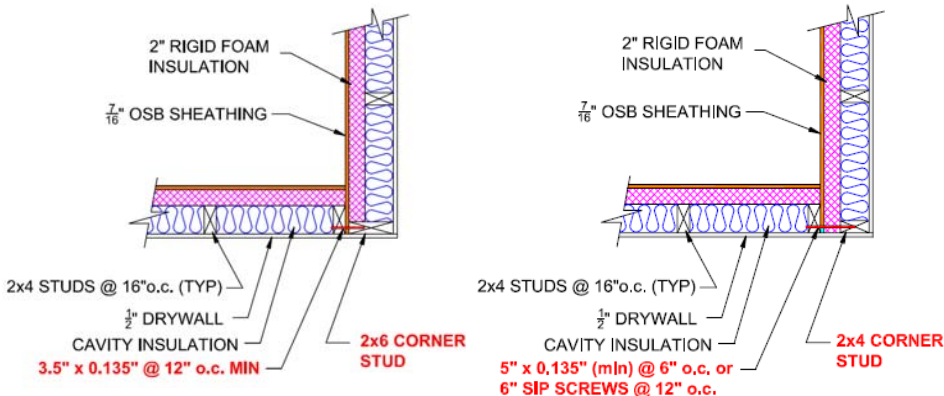

Left: Two recommendations for inside corners.

Raising Walls

Except for planning for OSB and foam joints to be offset, raising the EP&B wall is fairly typical. Prior to lifting the walls into place, apply caulk or foam to the underside of the bottom plate to air-seal the sole plate to the floor deck.

When there is a gap between adjacent studs of separate panels, apply spray foam or caulk first, then connect and fasten tightly. As with all wall panel joints, the gap should be sealed carefully, and a final bead of caulk should air-seal joints from the interior side of the wall.



Apply construction caulk at bottom plate to air-seal at floor deck.



Apply construction caulk at bottom plate to air-seal at floor deck.



Ensure air-seal at sole plate. Here, the OSB will lap the rim for improved seal.



Leave a gap at the top plate for tying adjacent panels together.



Plan the layering of foam and OSB so vertical material joints between adjacent panels occur at different studs.



When adjacent wall panels are in place, fill in the EP&B layers as necessary: rigid foam, then OSB, then WRB.

Connecting Outside Corners

Plan sheathing layers at outside wall corners so that OSB and rigid foam vertical joints do not land at the same stud, and ensure the rigid foam constitutes a continuous thermal break. If necessary, omit (or remove) foam at the ends of these walls where they will connect perpendicularly to the previously erected walls and abut the existing foam layer. The Grand Rapids crew utilized an outside corner with framing interior to the foam sheathing in both directions.



Removing a strip of FPIS to join thermal break at outside corner.



The gap provides a slot for the other wall's foam layer. Air-seal connection with caulk.



It is not possible to add foam or caulk once an exterior corner is in place, unless the OSB is added after erection.



Plan outside corners carefully to anticipate the layering of rigid foam, OSB, and WRB, and a bead of caulk or spray foam for air-sealing.

Building Short Walls

Framed sections that must be tipped up to fit between two parallel walls require planning. Frame the studs and plates as usual; however, anticipate the need for connecting foam and OSB layers—leave gaps that can be filled after the final wall is upright and connected to its perpendicular neighbors. This material can be added from the exterior once the wall is up.



Plan short, connecting end walls carefully to maintain an uninterrupted layer of rigid foam across outside corners. Remember to apply a bead of caulk prior to tipping up, and follow with caulk if necessary to ensure an air-seal.

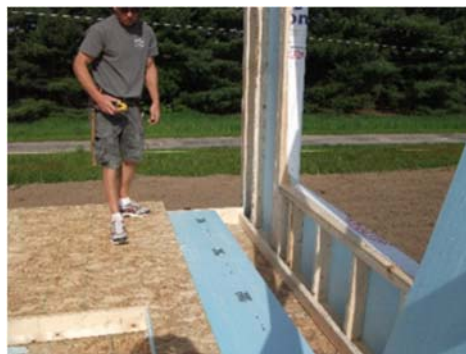

At outside corners, plan temporary gaps in the foam and OSB to leave knuckle room for erection and connection. The last sections of foam and OSB can then be added from the exterior side of the building. Ensure that foam and OSB joints do not land at the same stud.

Quality Assurance: Outside Corners and General Air-Sealing

Careful quality control at all connections is an important investment to achieve the full benefit of the EP&B wall's continuous layer of rigid foam. The WSP will be detailed as the air-control layer, so anticipate the bead of caulk or spray foam necessary to fully seal all joints and connections. The following series of photos illustrates the layers, methods, and order of operations.



Prepare the ends of the long walls for connection to the short wall. This outside corner configuration places the studs interior to the layer of rigid foam in both directions. Don't forget the continuous bead of caulk for air-sealing.



Raise the short wall and tie-in to the long walls on each side, with rigid foam and OSB gaps to allow maneuverability and connection, to be filled later from the exterior side of the wall.



Fill in the EP&B components at the outside corners of the short wall and provide a continuous rigid foam layer.



Fill in the EP&B components at the outside corners of the short wall—OSB.



Final detailing of outside corner connections.

Quality Assurance: Nailing

As with a typical frame wall, once all wall sections are up, check for missed nails at studs. Re-nail as necessary from outside (on ladder), before folding WRB into place. If any nail gun “misses” occurred where the WRB has already been stapled into place, nail through WRB and then seal the nail head with caulk or a piece of manufacturer-approved tape to maintain the WRB. For any areas where the WRB was folded back to allow tip-up, be sure to check for misses and re-nail as necessary before the WRB is unfolded and stapled to the sheathing.



If nails missed the stud, re-nail from outside.



Where possible, re-nail before fully attaching the WRB.



If it's necessary to nail through the WRB, seal each nail head with tape or caulk.



Double trusses at gable end walls are acceptable, but not required.



EP&B walls support trusses with WSP nailed to a double top plate.

Roof Trusses

Typical or raised-heel trusses can be used in the standard fashion with EP&B walls. The nailing schedule for attaching the sheathing to the double, full-width top plate provides ample bearing for the self-weight of the truss.

The test house photos show a double truss at the gable ends although it is not necessary for the EP&B configuration. The Grand Rapids framing crew typically uses let-in bracing instead of WSP-braced walls for shear load, and sheathes the house with 1-3/4-in. rigid foam, taping it to perform as the WRB. Two trusses sistered together for each gable end of the house ensures that the assembly bears on framing. The truss package had been ordered before the commitment was made to use EP&B walls.

WATER-RESISTIVE BARRIERS AND PAN-ADHERED FLASHING

For long-term durability, any wall system must be detailed to avoid bulk water intrusion. When properly installed over the EP&B's wood structural sheathing, a WRB provides protection against rain water entering the wall cavity from the outside. Look for a housewrap that resists tearing and always layer in shingle fashion. A WRB with texturing or vertical channels to provide a physical drainage plane behind the cladding is also worth considering.

Due to the low-permeability of the foam sheathing directly behind the OSB, drying of the wood sheathing in an EP&B wall must be outwards. A high-perm WRB is recommended (≥ 40 perms) and will also allow outward drying of water vapor resulting from incidental moisture that may accidentally get behind the WRB.

Installation of the WRB at windows is the same as over wood sheathing in typically-framed homes—use standard best practices for all openings and penetrations, including pan flashing installed in a shingled fashion.



See Building America Resource: <https://basc.pnnl.gov/resource-guides/fully-flashed-window-and-door-openings>

EP&B MOISTURE CONSIDERATIONS

The following table lists the calculated temperatures at important locations within the wall for EP&B and other wall types when the outdoor temperature is 24° F. The foam sheathing keeps the wall cavity warmer than cavity insulation only, reducing the potential for condensation. Note that for typical light-framed walls, the OSB interior plane is coincident with the cavity’s exterior plane. In the winter, the vapor drive is outward, due to warmer, moister air inside so an interior vapor retarder is especially important, because if moisture reaches this location it is very likely to condense. Note the protection offered by the c.i., and the below-freezing temperatures calculated for walls without a rigid foam layer.

Temperature Profile Calculated Temperatures(°F) in the Wall when Outdoors is 24°F.			
Interface/Wall Assembly	EP&B, R13/10	2x4, R13	2x6, R20
Indoor Temperature	68.0	68.0	68.0
Gypsum/Cavity Interface	66.2	64.8	65.8
Cavity/Rigid Foam Interface	43.7	N/A	N/A
OSB Interior Plane	26.5	28.1	26.9
OSB Exterior Plane	25.4	26.2	25.5
Outdoor Temperature	24.0	24.0	24.0

Reduced framing, c.i., and low air infiltration are characteristics common to many high-performance wall systems, including EP&B. To control airborne moisture migration, always use air-sealing best practices. Rigid foam joints should be butted firmly to each other, and to the framing members they touch, to ensure uniform coverage with no gaps. Foam joints should either be taped from the outside (before the installation of the OSB) or sealed at plates and each side of the stud on the interior side with either caulk or spray foam. The Grand Rapids house had a flash coat of closed-cell spray polyurethane foam (ccSPF) added prior to installation of cavity insulation, which provides reliable air-sealing.

EP&B wall test data in CZ 4 shows stable wood moisture content for the system (graph below, blue lines). Compare the EP&B performance to the acceptable but cyclic performance of a standard wall without a c.i. layer (graph, green lines). Also note the large moisture variations of OSB sheathing when a vapor barrier is omitted from a typical 2x4 wall in CZ 4 (dotted pale green line). This tendency increases for CZs 5 and up, as a result of the greater vapor drive caused by colder outdoor winter temperatures.

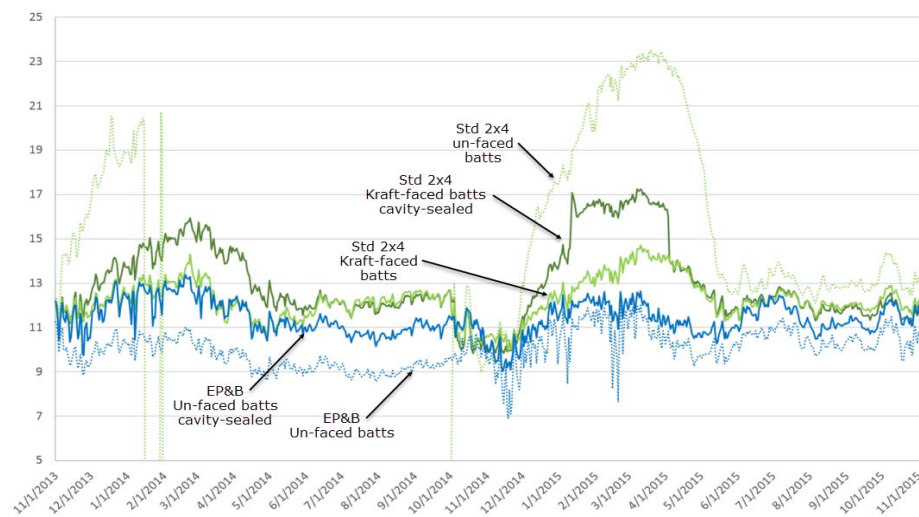

Controlled field tests conducted by Home Innovation Research Labs from Nov. 13–15, 2014, in CZ 4 on north-facing walls show OSB moisture content (MC%). EP&B walls (blue lines) stay drier than conventional walls.

Note: Despite the gap in data for the 2x4 wall with unfaced batts from 2/1/2014 to 10/1/2014, the data collected on the remaining dates corroborates the trend.

Source: Home Innovation Research Labs: Characterization of Moisture Performance of Energy-Efficient Light-Frame Wood Wall Systems—Phase II, December, 2015.

Window Installation



Frame window openings with 2x4 lumber to maximize c.i.

Windows in an EP&B wall do not require major changes to typical practice, unless required by the window manufacturer.

The demonstration house used flanged windows, which are installed from the outside, flush to the exterior wall plane. The factory window frame can bear on the edge of the OSB and the rigid foam, and is supported mainly by nails through the flanges and the OSB. If desired, the window sill framing (2x4) can be extended (2x6) like the top and bottom plates of the wall, but this is not required, and the added framing increases thermal bridging.

The test house crew typically builds a light-framed wall with let-in bracing and no WSP, where rigid foam acts as the sheathing—their habit is to add a 1x6 at the sill to span from the framing to the foam sheathing. They did that with the EP&B wall in the test house, as well. The added thermal bridging is minimal, and will not adversely affect performance. You are welcome to add this 1x6 member for added support, but it is not necessary. If you do add it, be sure to account for the depth of the sill material in your layout of the rough openings.



1x6 sills may be added for convenience but are not necessary.

Nail the window flanges to the OSB using 2-in. galvanized, ring shanked cap nails at approximately every other hole. In our demonstration house, one window had an unusually short flange, and the nails did not engage OSB. In this case, the crew used 3-1/2-in. nails to catch the framing through the 2-in. foam layer. For added strength, 3-1/2-in. nails could be used at all window flanges to connect to framing through the foam, but this is not required.

Window Flashing

Apply flexible, self-adhered pan flashing and jamb flashing according to typical best practices. Although WRB manufacturers often suggest an inverted Y-cut at each corner to allow turning in the WRB to wrap the rough opening, other reliable methods include cutting the WRB flush to the outside sill edge (and flush with the jamb edges in areas with high probability of wind-driven rain) so the flashing can adhere directly to the framing of the rough opening and avoid any possibility that water may make its way between the framing and the WRB.



Window opening, WRB folded back, 1x6 sill plate added (not required).



Flexible, self-adhered pan flashing tape, cut to length.



Pan flashing should be as flat as possible at corners.

Window Flashing and Details

In an EP&B wall, the OSB sheathing provides a solid substrate for window detailing, as with typical light-framed walls. You can find an in-depth discussion of window flashing and water-sealing methods here:

<http://www.homeinnovation.com/~media/Files/Reports/TechNote-Window-and-Door-Flashing.pdf>.



Apply flexible, self-adhered pan flashing, extending several inches up the jamb on each side. Smooth out all wrinkles.



Apply jamb flashing in shingled layers from bottom to top.



Apply head flashing as the final layer, and then tape the WRB flap over the head flashing.

The additional c.i. layer provided by the EP&B wall system is evident at openings.

Per best practices, ensure all windows operate as expected prior to final detailing.

Sliding Door Installation

Unless extra strength is required, sliding door framing can be 2x4. Full-depth framing (2x6 if building a 2x4/2x6 EP&B configuration) can be considered for oversized sliding glass doors, to ensure the horizontal forces bear directly against framing lumber.

For the sliding glass patio door and the deck's ledger board, the crew used typical best practices for aprons, pan, head and jamb flashing, and drip caps.

Where extra stability is desired, a 3-1/2-in. spiral shanked nail may be used to connect the sliding door's flange directly to the framing.



Apron and stainless steel pan at sliding door opening, leading to elevated deck on the north side of the house.



Sliding door installed in opening.



Install windows and doors only after the opening has been properly detailed.



Sills of patio doors require special attention because decks may have standing water.



WRB above the door is folded up and away, and is the last waterproofing component to be folded down, as the top "shingle" to prevent bulk water intrusion by shedding water instead of trapping it.



All components of a good waterproofing detail are layered bottom-to-top.



Self-adhesive jamb flashing should be installed snug to the window frame.



Use a 3-1/2-in. spiral or ring shank nail where direct engagement to framing is desired for added security.

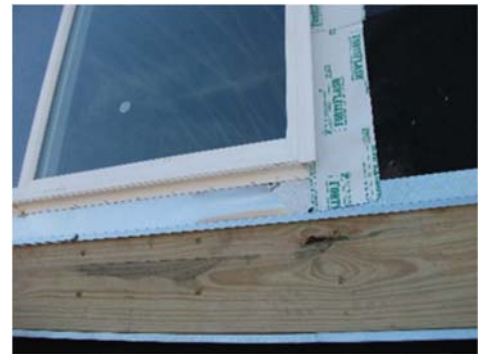

Bottom to top waterproof layering.



Install jamb and head flashing in shingle fashion.



Smooth wrinkles and press out air pockets to avoid imperfections that can trap water.



Caulk or seal with WRB tape all new penetrations through flashing.

Hinged Door Installation

All exterior hinged doors should be ordered with 6-in. jambs to fill the full width of the wall. Unless extra strength is required, the wall framing opening for the door can be 2x4 lumber; the hinge frame and jamb connection occur at the interior framing, so the 2x4 is in plane with the door's operation.

Prior to inserting the door to the garage (where there is no WRB) apply a continuous bead of silicone caulk where the brick mold meets the face of the OSB to air-seal the connection.



Door installation in an EP&B wall is similar to standard construction.



Tipping the door into place. Note that between the house and garage, the OSB was detailed as the air control layer.



Squaring the door.



Plumbing the door.



Nailing the door frame.



Exterior doors need 6-in. jambs to match the wall width of a 2x4/2x6 EP&B wall.



The factory-drilled securement jamb holes match up with the framing of an EP&B wall.

Siding Installation

One of EP&B’s strongest advantages is the simplification of siding installation.

Using the alternate schedule IRC R.402.13, siding can be attached directly to the OSB sheathing of an EP&B wall, and is similar to installing siding over structural insulated panels. The IRC has included a table specifying attachment of siding weighing 3 psf or less (most fiber cement siding qualifies) to wood structural sheathing (see the following images).

The Grand Rapids test house was built over a pre-insulated, pre-cast concrete basement foundation. Furring strips were added to allow a seamless transition for horizontal vinyl siding.

Note: Alternately, siding or other types of exterior finishes may use nails or screws of sufficient length to attach through both the wood structural sheathing and 2-in. foam layer to engage the framing with penetration to the depth required by IRC Section R703.3.3, at the prescribed frequency. Be sure to coordinate with the siding crew by marking the framing geometry and stud locations, especially if WRB is installed by the framing crew.



Apply WRB and siding with standard methods.



The completed house looks clean, crisp, and traditional.

Fastening Exterior Finishes—the IRC provides an alternate schedule for fastening directly to structural sheathing.

Adapted from 2015 IRC TABLE R703.3.2 OPTIONAL SIDING ATTACHMENT SCHEDULE FOR FASTENERS WHERE NO STUD PENETRATION NECESSARY	
NUMBER AND TYPE OF FASTENER	SPACING OF FASTENERS ^b
Ring shank roofing nail (0.120" min. dia.)	12 in. o.c.
Ring shank nail (0.148" min. dia.)	15 in. o.c.
#6 screw (0.138" min. dia.)	12 in. o.c.
#8 screw (0.164" min. dia.)	16 in. o.c.

Exterior wall covering (weighing 3 psf or less) attachment to wood structural panel sheathing, either direct or over foam sheathing a maximum of 2 in. thick.^a

Note: Does not apply to vertical siding.

^a Fastener length shall be sufficient to penetrate back side of the wood structural panel sheathing by at least 1/4 in. The wood structural panel sheathing shall be not less than 7/16 in. in thickness.

^b Spacing of fasteners is per 12 in. of siding width. For other siding widths, multiply “Spacing of Fasteners” above by a factor of 12/s, where “s” is the siding width in inches. Faster spacing shall never be greater than the manufacturer’s minimum recommendations.

EP&B INSULATION

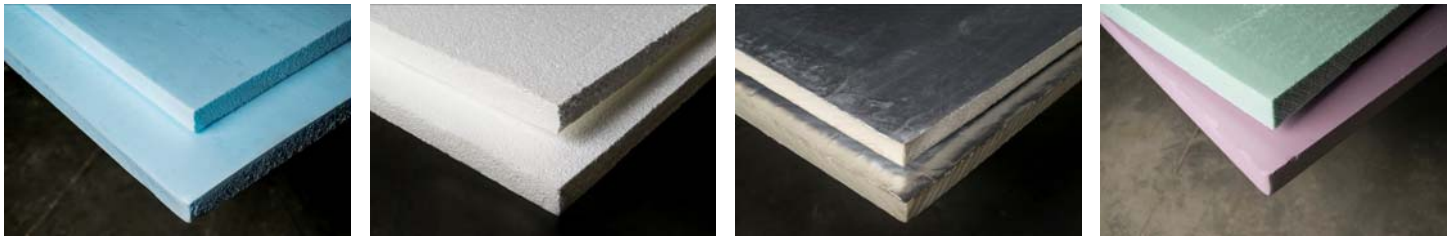

Rigid foam insulation, from left: XPS, EPS, PIC, XPS.

Choose the Insulation that Meets Your Needs



Mineral wool batt Cellulose

Fiberglass batts with Kraft paper facing Unfaced fiberglass batts



Insulation choices for an EP&B wall are similar to the options for standard framed walls. Mix and match cavity fill and rigid c.i. to achieve the IECC prescriptive minimums (or greater) for your CZ (see table).

Also consider the moisture characteristics of these choices; see the following section on interior vapor retarders.

Foam plastic insulating sheathing is recommended for the EP&B c.i. layer for its compressive strength (minimum 15 psi) and low level of moisture permeance. Due to its high perm rating, EPS is recommended ONLY if it has a film facing or a low-perm film is added. For single-faced rigid insulation board, the film must be installed facing the cavity, not toward the sheathing. Because mineral wool board is not faced and not sufficiently rigid, it is not suitable for the c.i. layer of an EP&B wall. The following rigid foam sheathing products are recommended for use in an EP&B wall system:

- XPS (Extruded Polystyrene – blue, pink, yellow, or green);
- EPS (Expanded Polystyrene – typically white with a characteristic beaded appearance; use faced only); and PIC/Polyiso (Polyisocyanurate – yellow or tan with a foil facing).

Note: The demonstration house was insulated with a 1-in. flash coat of ccSPF (a reliable air-sealer), followed by a low-moisture fibrous blown insulation.

Typical Insulation Thermal Performance Values^{a, b, c}

Rigid Insulation: Nominal R-Value per 2 in. layer

EPS – Expanded Polystyrene	8
GPS – EPS with graphite	9
XPS – Extruded Polystyrene	10
XPS* – blown with low GWP blowing agent ^d	8
PIC – Polyisocyanurate	12

Cavity Insulation: Nominal R-Value per 3.5 in. layer

Fiberglass Batt (3-1/2, 3-5/8, hi-density)	11, 13, 15
Cellulose (dense-pack wall or blown)	12.5
Blown Fiberglass (loose, dense)	12.5, 14
Mineral Wool Batt (standard, hi-density)	12.5, 14
Spray Polyurethane Foam (SPF) (open cell, closed cell)	12.5, 12 to 23

^a Values shown are typical; check manufacturer’s specifications for actual performance

^b Thermal Resistance is measured in the unit $R = (\text{hour} \times \text{ft} \times \text{°F})/\text{Btu}$

^c Refer to the climate zone map and *Table R702.7.1 Class III Vapor Retarders* to ensure your chosen combination meets IECC prescriptive insulation requirements for frame walls

^d The Global Warming Potential (GWP) of CO₂ = 1. Some low-GWP blowing agents with GWP <5 have been tested to produce R per inch performance that is 20% or more below XPS produced by standard methods. Check manufacturer’s specifications.

EP&B INTERIOR VAPOR RETARDERS

Climate Zones 1–4 (except Marine 4) do not require vapor retarders according to IRC Section R702.7 and Table R702.7.1. Climate Zones 5–8 and Marine 4 require a Class I or II vapor retarder on above-grade walls unless certain conditions regarding vented cladding or c.i. are met, in which case it is permitted to use a class III vapor retarder.

Because an EP&B wall includes a 2-in. layer of c.i., in most cases a Class III vapor retarder may be used. See the following table for direction. If the configuration you’ve chosen does not qualify for Class III interior vapor retarder, then Home Innovation recommends a Class II vapor retarder, such as Kraft facing on batt insulation. Proprietary “smart” vapor retarder products have perm ratings that rise with increasing relative humidity from 1 perm or less at normal conditions (Class II) up to 35+ perms (vapor permeable) in high humidity, and represent a “belt and suspenders” approach, excellent for use with EP&B. In any situation expected to have a higher than normal interior vapor drive, Home Innovation strongly encourages the use of an interior vapor retarder:

- High internal moisture load due to high human and pet occupancy; and
- Very low outdoor temperatures.

CAVITY INSULATION INSTALLATION

The Grand Rapids test house received a 1-in. flash coat of closed cell spray foam, followed by blown-in fiberglass.

The ccSPF serves several functions, acting as both a reliable air barrier and a vapor retarder.



Home Innovation discourages the use of Class I interior vapor retarders (like polyethylene sheeting) as it may create a double-vapor barrier condition, trapping incidental moisture and limiting drying.

IRC Interior Vapor Retarder Requirements as They Apply to the EP&B Wall System
(See IRC Table R702.7.1 Class III Vapor Retarders)

Climate Zone	EP&B Rigid Insulation, 2 in.	c.i. R-Value	2x4/2x6 EP&B	2x6/2x7.5* EP&B
1, 2, 3, Non-Marine 4	EPS, GPS, XPS*, XPS, PIC	8–12	None required.	
Marine 4, 5	EPS, GPS, XPS*, XPS, PIC	8–12	A minimum Class III vapor retarder is required . A Class II vapor retarder such as Kraft-faced batts or a “smart” film is recommended for the EP&B wall system.	
6	EPS, GPS, XPS*, XPS, PIC	8–9	A minimum Class III vapor retarder is required .	A minimum Class III vapor retarder is required for any c.i. choice other than PIC (R-12).
			A Class II vapor retarder such as Kraft-faced batts or a “smart” film is recommended for both configurations of the EP&B wall system.	
7, 8	EPS, GPS, XPS*	8–9	A minimum of a Class II vapor retarder such as Kraft-faced batts or a “smart” film is required .	
	XPS, PIC	10–12	A minimum Class III vapor retarder is required . A Class II vapor retarder such as Kraft-faced batts or a “smart” film is recommended for the EP&B wall system.	A minimum of a Class II vapor retarder such as Kraft-faced batts or a “smart” film is required .

INSTALLATION SPECIFICATION FOR EP&B WALL SYSTEMS

Equipment

Rigid foam sheathing can be cut with a table saw, circular saw or reciprocating saw. New toothless circular saw blades are available in 7-1/4 in. and 10 in. diameters for nearly dust-free cutting. Use eye and breathing protection per manufacturer’s instructions.

Many standard framing nail guns will accommodate the 3-1/2-in. nails required to fasten the WSP to the studs through the 2-in. foam sheathing. The fastener pattern of 3 in. o.c. at the WSP perimeter and 6 in. o.c. in the field will be familiar from traditional stapling schedules. Note that staples are not an acceptable substitute for nails in the EP&B wall system.

Design Value and Other EP&B Configurations:

The EP&B wall’s calculated allowable design racking shear load value is 256 plf (lbs/ft). The EP&B wall system can be adapted to 2x6 stud framing, using true 7.5 in. plates (cut from 2x10s) and 2-in. thick rigid foam. Nominal 2x8 plates with 1-3/4 in. c.i. requires two layers of rigid foam: (1) 1-in. and (1) 3/4-in. The 2x7.5* configuration is more cost effective and meets IECC code requirements in more climate zones. Modify the following specifications for either option.

King Studs at 1st-Floor Openings—with rim header^a

Opening Width, ft	# At Window	# At Door ^b
3	1	1
4	2	1
6	3	2
8	3	2
10	4	3
12	5	4

^a The number of 2x4 king studs at each side of the opening.

^b Number of king studs is reduced at door opening only if the first stud (buck) is a 2x6 member.

EP&B Changes to Standard Light Frame Wall Construction.

Design	Standard 2x4 Frame Wall	Extended Plate and Beam
Wall plates	Bottom and top plates all 2x4	Bottom and top plates all 2x6
Wall studs	2x4	2x4
Wood structural panel	Exterior to the studs. Horizontal breaks in the wall plane require blocking.	Exterior to foam sheathing. Continuous vertical sheathing (plate to plate) is required—no horizontal breaks are allowed in the wall plane between the top and bottom plates. Use plywood or OSB of 3/8-in. to 15/16-in. thickness.
Insulating sheathing	Optional, exterior to (or in place of) the structural sheathing	Standard, exterior to the 2x4 studs, interior to the structural wood sheathing. Install vertically, staggering foam board joints with OSB joints.
Drainage plane	WRB over the wood structural sheathing. If FPIS is used, either exterior or interior to the FPIS	WRB over the wood structural sheathing
Window Installation	Typical, per manufacturer’s instructions	Typical, per manufacturer’s instructions. For convenience, a 1x6 sill may be added but is not required.
Sheathing attachment	2.5 in. nails Panel Edge: 6 in. spacing Panel Field: 12 in. spacing	3.5 in. nails Panel Edge: 3 in. spacing Panel Field: 6 in. spacing
Rim Board, foundation	Typical rim, per IRC	Double rim if flush; single or double rim where inset 1 in. for c.i. (2 in. if WSP is installed continuously from top plate to sill plate, lapping the rim, and fastened to the sill plate per the schedule.)
Rim board between floors	Typical rim, per IRC	Double rim if flush; single or double rim if inset 1 in. A double rim may act as a beam header, eliminating headers and allowing for additional insulation. Use joist hangers above openings with rim beam header. Single rims require traditional window and door headers per IRC.
Roof Trusses	Typical, per IRC	Typical, per IRC. Unlike with traditional c.i. installed as over-sheathing, single engineered roof trusses may be used with an EP&B wall no modification at gable ends.

INSTALLATION SPECIFICATION FOR EP&B WALL SYSTEMS

Example Scope of Work: 2x4 Studs with 2x6 Plates (*customize for your particular project*)

1. Introduction

- 1.1. This scope of work addresses the construction procedure for field-framed EP&B walls in a two-story building with a basement or a crawlspace.
- 1.2. This scope of work addresses the EP&B configuration constructed using 2x4 stud and 2x6 plates.
- 1.3. The construction procedure addresses framing and sheathing (including structural and foam sheathing).
- 1.4. The primary focus is on the methods and materials that are unique to the EP&B system or impacted by the EP&B system design. Where framing practices are not altered by the EP&B design, typical construction methods and material shall be used.
- 1.5. All headers shall be in accordance with building code or an approved, engineered design.
- 1.6. With the exception of the wall structural sheathing nailing schedule that is unique to the EP&B system (3-1/2-in. x 0.131-in. dia. @ 3-in./6-in. perimeter/field), all fastening requirements are consistent with building code requirements for light-frame wood walls as applicable. Approved alternatives shall be permitted.
- 1.7. Calculated allowable design racking shear load value for the EP&B wall as tested is 256 plf.
- 1.8. For additional information, refer to construction details provided with the Scope of Work.

2. Materials List

- 2.1. Dimension lumber: stud grade or higher.
- 2.2. Wall sheathing: WSP – plywood or OSB of 3/8-in. to 15/32-in. thickness.
- 2.3. Engineered or solid wood rim board.
- 2.4. Metal joist hangers (at first-floor openings only – rim header application) per engineered design.
- 2.5. Structural composite lumber (second-floor headers and rim joist application at first floor).
- 2.6. Insulating rigid foam board sheathing (EPS, XPS, or PIC; see page 28—consider the climate characteristics and the rigid foam moisture performance carefully when choosing materials combinations).
- 2.7. Fasteners per construction details.
- 2.8. WSP floor sheathing and engineered floor joists per building plans.

3. Field-Framing Guidelines

3.1. Sill Plate and First-Floor Construction

- 3.1.1. Verify sill plate anchor bolt size and spacing is in accordance with the house plans. The anchor bolt edge distance from exterior edge of the foundation wall should be approximately 3.5 in. to allow for the double rim joist installation, modified appropriately for other rim joist solutions.

- 3.1.2. Install minimum 2x6 pressure treated sill plate and secure using nuts over an appropriately-sized washer.
- 3.1.3. Install a double 1.25 in. engineered wood rim joist inset 1 inch from the exterior face, faced-nailed at a nominal spacing of 24 in. o.c. at top and bottom edges and toenailed to sill plate with 8d nails (2-1/2 in. x 0.113 in.) at 6 in. o.c.
- 3.1.4. Install 1-in. thick rigid foam insulation board. To the exterior of the rim joist and detail for a complete thermal break.
- 3.1.5. Install engineered floor joists and floor sheathing in accordance with the building plans.

3.2. Wall Construction

- 3.2.1. Lay out 2x6 bottom (sole) plate.
- 3.2.2. Lay out 2x4 studs at 16 in. o.c.
- 3.2.3. Lay out 2 x 6 first top plate and second top plate.
- 3.2.4. Attach bottom plate to studs and first top plate to studs using (2) 3-1/2 in. x 0.135 in. nails end-nailed at each connection, keeping the interior face of the studs and plates flush.
- 3.2.5. Attach 2 x 6 second top plate to the first top plate using 10d nails (3 in. x 0.128 in.) at 24 in. on center. End joints in double top plates shall be offset at least 24 in. and a minimum of eight (8) 10d nails (3 in. x 0.128 in.) shall be installed in the lapped area. In lieu of the offset, double top plates may be fastened to each other with an approved metal plate connector.
- 3.2.6. Mark the plates with the location of studs (needed for attaching WSP sheathing after foam sheathing is installed).
- 3.2.7. Install 2-in.-thick rigid foam sheathing over 2x4 studs between 2x6 top and bottom plates. The foam sheathing shall be oriented vertically and all vertical edges shall occur over studs. The foam sheathing can consist of two layers of 1-in.-thick panels or a single 2-in.-thick layer. If two layers are used, stagger the joints. Rigid foam sheathing shall fill the entire space between the 2x6 top and bottom plates except at openings (see Sections 3.3 and 3.5 for framing at openings). The edge/end joints of foam sheathing panels shall be tight against each other and against 2x6 plate framing members.
- 3.2.8. If the rigid foam layer is to be detailed as the air barrier, the foam board seams shall be taped to each other and to framing using manufacturer-approved adhesive tape. Alternatively, once the wall is tipped into place a bead of chemically-compatible caulk or spray foam may be applied from the cavity side at all material connections.
- 3.2.9. Install 7/8-in. WSP sheathing over the insulating rigid foam sheathing. Avoid coincident vertical joints of rigid foam and WSP by staggering the sheathing course to align on different studs. The WSP sheathing shall be

INSTALLATION SPECIFICATION FOR EP&B WALL SYSTEMS

oriented vertically and shall be continuous between top and bottom 2x6 plates. Horizontal WSP orientation or horizontal joints in WSP sheathing shall not be permitted (blocked or unblocked). WSP sheathing shall overlap top and bottom plates by a minimum of 1 in. to allow installation of sheathing nails. All vertical edges shall occur over studs. Use of elongated WSP panels that extend over the rim joists below and/or above the wall is permitted, and is required if the rim joist is inset by 2 in. instead of 1-in., in which case the 3-in. o.c. nails shall attach the bottom edge of the OSB to the sill plate directly.

- 3.2.10. Allow 1/8-in. gap at all WSP edges (or in accordance with WSP manufacturer's recommendations).
- 3.2.11. Attach WSP sheathing to 2x6 top and bottom plates and to 2x4 studs using nails in accordance with the following schedule:
- At perimeter of WSP sheathing: a minimum 3.5 in. x 0.131 in. at maximum spacing of 3 in. o.c.
 - At 2x4 studs in field of WSP sheathing: a minimum 3.5 in. x 0.131 in. at maximum spacing of 6 in. o.c. to allow 1-in. penetration into the framing.

3.3. First-Floor Openings

- 3.3.1. Window bucks are framed using 2x4 studs.
- 3.3.2. Door bucks are framed using 2x4 studs if exterior door jambs are the full thickness of the wall; otherwise 2x6 bucks are required for framing engagement.
- 3.3.3. The space above all openings is framed as for a non-bearing wall (use rim header design – see Section 3.4).
- 3.3.4. Horizontal door/window buck at the top of the opening shall be a continuous member and shall be attached to the exterior WSP sheathing using sheathing nails at 3 in. o.c. (to provide support for the horizontal buck member).
- 3.3.5. The number of king studs shall be determined based on the size of the opening in accordance with the table on page 30 or approved engineered design. (Note: a window or door buck continuous from bottom to top plate is a king stud.)
- 3.3.6. WSP sheathing is connected to window or door bucks using 3.5 in. x 0.131 in. nails at 3 in. o.c.

3.4. Rim Headers and Second-Floor Construction

- 3.4.1. Install double 1.25 in. engineered wood rim joist along the entire perimeter of the wall, inset 1 in. per 3.1.3.
- 3.4.2. Rim joists shall not have splice joints over an opening and the first splice joint to each side of the opening shall occur a minimum of 6 in. away from the opening edge and past the outermost king studs (rim header application).
- 3.4.3. Double rim joist shall be face-nailed at top and bottom edges at a nominal spacing of 24 in. o.c. and at 16 in. o.c. over openings with minimum 2.5-in. x 0.131-in. nails. The exterior rim shall be toe-

nailed to top plate with 8d nails (2.5-in. x 0.113-in.) at 6 in. o.c.

- 3.4.4. The maximum rim joist span shall be verified by a licensed professional. (Note: A double 1.25 x 11.875 structural composite lumber member is sufficient for most openings up to 8 ft wide).
- 3.4.5. Install engineered wood floor joists in accordance with the floor plans.
- 3.4.6. If using Rim Beam design, floor joists located above an opening shall be supported by a metal joist hanger selected by a licensed professional based on design loads.
- 3.4.7. Install WSP floor sheathing in accordance with the building plans.

3.5. Top-Floor Openings

- 3.5.1. Top floor openings are conventionally framed using single 1.25-in. to 1.5-in.-thick engineered or solid wood headers (up to 5 ft–7 ft) or double engineered or solid wood headers (for larger openings).
- 3.5.2. Where single header is used, it is insulated with 2-in. rigid foam sheathing on the interior face of the header.
- 3.5.3. Headers are supported by jack studs. The number of jack studs and king studs is determined based on standard practice in accordance with building code or engineered design.

3.6. Corner Details (Exterior Walls)

- 3.6.1. Construct wall corners at intersecting exterior walls using one of the details provided in this Construction Guide. (pgs. 3 and 13).
- 3.6.2. Framing members at the corners shall be arranged in a manner to minimize thermal bridging and allow for increased quality of insulation installation. Rigid foam sheathing insulation is installed at the corners as provided in the details.
- 3.6.3. The intersecting walls shall be connected to each other at the corner using one of the following options:
- Adjacent framing members are nailed directly to each other using 3.5 in. x 0.135 in. nails at 12 in. o.c.
 - Exterior WSP sheathing from both intersecting walls is nailed directly to a common 2x framing member using minimum 2.5 in. x 0.131 in. nails spaced a maximum of 6 in. o.c. (for each wall).
 - Other approved fastening methods.
- 3.6.4. Double top plates are overlapped at corners and intersections, and two (2) 3 in. x 0.128 in. nails are installed at each lap (face-nailed). Alternatively, the intersecting walls are fastened to each other with an approved metal plate connector, per IRC Section R602.3.2.



U.S. DEPARTMENT OF
ENERGY

Office of
**ENERGY EFFICIENCY &
RENEWABLE ENERGY**

For more information, visit: buildingamerica.gov

DOE/EE-1730 · March 2018