

DESIGN GUIDE

Residential PEX Water Supply Plumbing Systems

Second Edition

Applications
Advantages
Material Properties
Joining Methods
Code Acceptance
System Design
Installation
and more

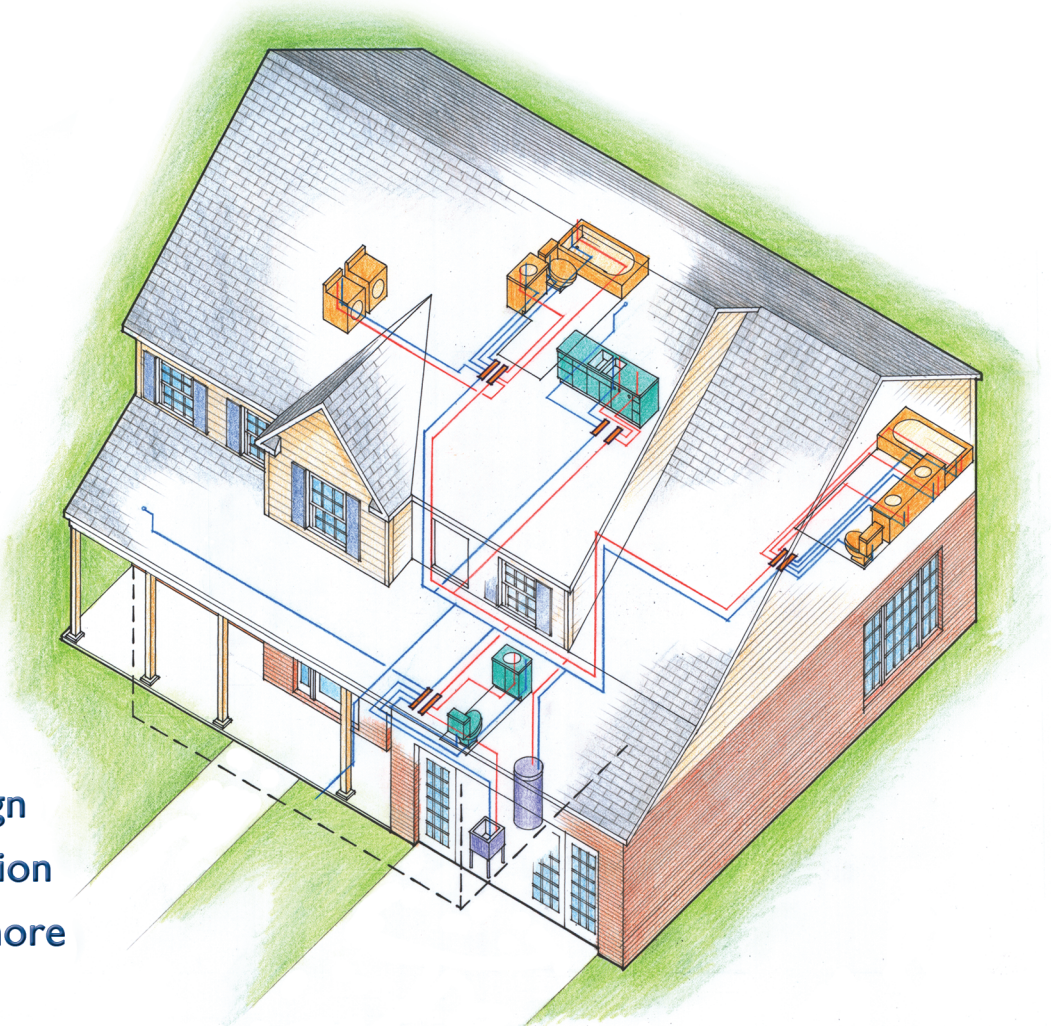

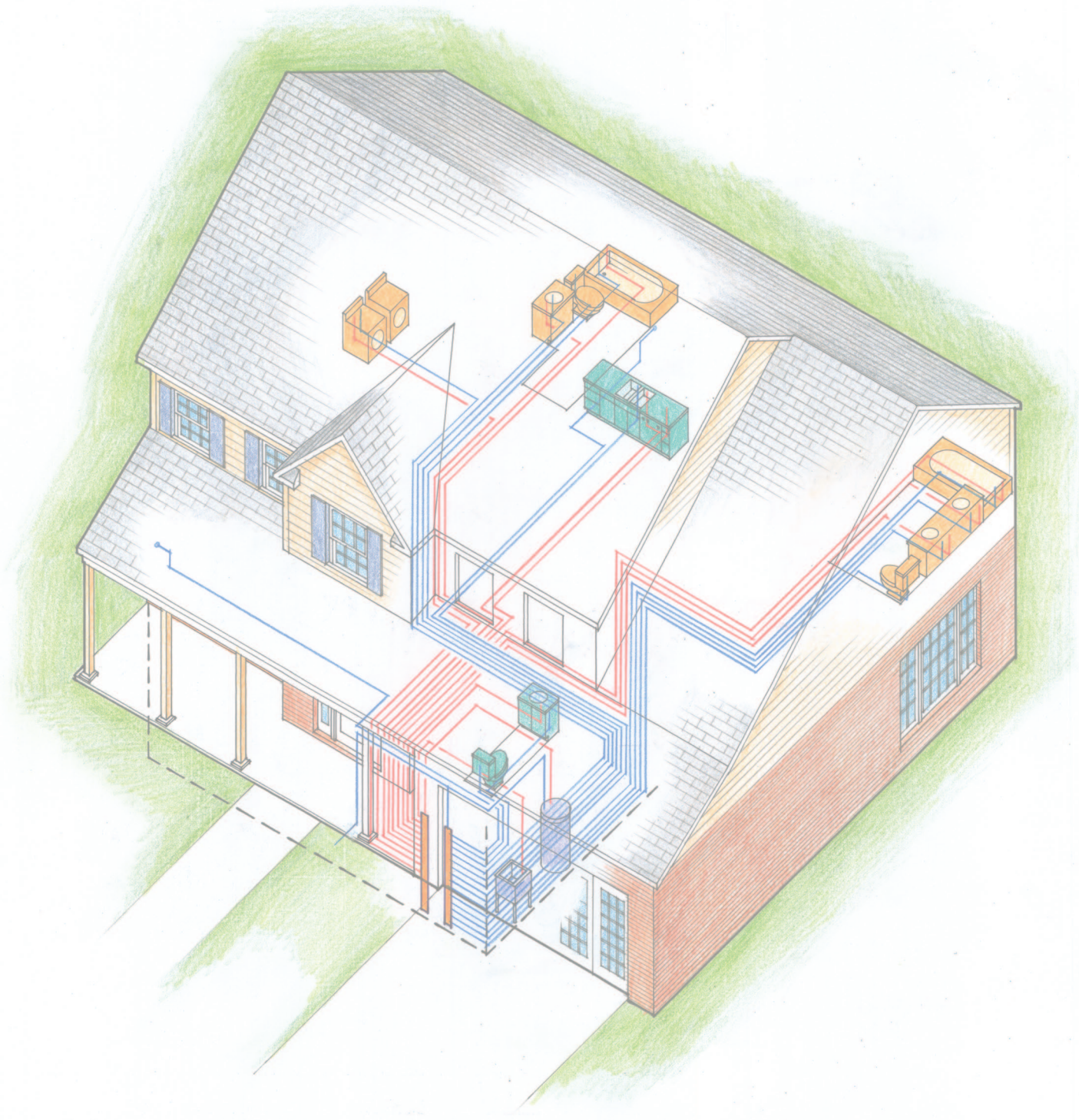

DESIGN GUIDE

Residential PEX Water Supply Plumbing Systems

Second Edition

Prepared for



Plastics Pipe Institute, Inc (PPI)
105 Decker Court
Suite 825
Irving, TX 75062
www.plasticpipe.org

and



Plastic Pipe and Fittings Association

Plastic Pipe and Fittings Association (PPFA)
800 Roosevelt Road, Bldg. C, Ste. 312
Glen Ellyn, IL 60137
www.ppfahome.org

Prepared by



Home Innovation Research Labs
(formerly the NAHB Research Center, Inc.)
400 Prince George's Boulevard
Upper Marlboro, MD 20774
www.HomeInnovation.com

November 2013

This document was developed as the result of a consensus process involving the Plastic Pipe Institute, the Plastic and Plastic Pipe and Fitting Association, and representatives from numerous piping and fitting manufacturers. It was prepared by the Home Innovation Research Labs.

Acknowledgements

We would like to thank the following principal contributors to this Guide:

NIBCO, Inc.
Elkhart, Indiana

Tom Coe

Plastic Pipe and Fittings Association
Glen Ellyn, Illinois

Richard Church, Mike Cudahy

Plastics Pipe Institute
Irving, Texas

Randy Knapp

REHAU, Inc.
Leesburg, Virginia

Lance MacNevin

Uponor
Apple Valley, Minnesota

Kate Olinger, Mike Rivers

Viega, LLC
Wichita, Kansas

Gary Morgan, Christina Smith

Watts
Springfield, Missouri

Chris Haldiman

Zurn Plumbing Products Group
Commerce, Texas

Gary Runyan

ICC – ES
Whittier, California

Maribel Campos

NSF International
Ann Arbor, Michigan

Nasrin Kashefi

Home Innovation Research Labs
Upper Marlboro, Maryland

Joseph Wiehagen

Copyright

Copyright © 2006, revised 2013 Home Innovation Research Labs, Inc., Plastics Pipe Institute, Plastic Pipe and Fittings Association. All rights reserved.

Disclaimer

Neither the Home Innovation Research Labs, Inc., the Plastics Pipe Institute, the Plastic Pipe and Fitting Association, the U.S. Department of Housing and Urban Development, nor any person acting in its behalf, makes any warranty, express or implied, with respect to the use of any information, apparatus, method, or process disclosed in this publication or that such use may not infringe privately owned rights, or assumes any liabilities with respect to the use of, or for damages resulting from the use of, any information, apparatus, method, or process disclosed in this publication, or is responsible for statements made or opinions expressed by individual authors.

For Further Information:

Please consult the following websites for the latest version of this publication. Print on demand version available through ICC ES only.

Plastics Pipe Institute
<http://www.plasticpipe.org/>

Plastic Pipe and Fittings Association
<http://www.ppfahome.org/>

Home Innovation Research Labs
<http://www.HomeInnovation.com>

ICC Evaluation Service, LLC
www.icc-es.org

Table of Contents



Chapter 1 – INTRODUCTION	1
The Second Edition	1
Objective.....	1
Background	2
Applications.....	3
How to Use the Design Guide.....	4
Chapter 2 – ADVANTAGES.....	7
Ease of Installation.....	7
Durability.....	7
Cost Effectiveness	7
Energy Efficiency.....	8
Noise Reduction	8
Water Conservation.....	8
Environmentally Sound.....	8
Versatility.....	9
Chapter 3 – MATERIAL PROPERTIES.....	11
Temperature and Pressure Capabilities	12
Corrosion Resistance	12
Erosion.....	13
Tuberculation	13
Lower Thermal Conductivity/Lower Specific Heat	13
Flexibility.....	13
Noise and Water Hammer Resistance.....	14
Resistance to Freeze Damage.....	14
PEX Material Designation Code	14
Resistance to Chlorine and Chloramines	15
Ultraviolet (UV) Resistance	16
Safe for Drinking Water.....	17
Chapter 4 – CODE ACCEPTANCE	19
International Residential Code (IRC-2012)	19
International Plumbing Code (IPC 2012)	21
International Mechanical Code (IMC 2012)	22
International Energy Conservation Code (IECC 2012).....	22
Uniform Plumbing Code (UPC-2012)	23
Green Plumbing & Mechanical Code Supplement (IAPMO 2010)	24
National Standard Plumbing Code (NSPC 2009)	25
National Plumbing Code of Canada (NPCC 2010)	25
Chapter 5 – JOINING METHODS	27
Cold Expansion Fittings with PEX Reinforced Rings	28
Cold Expansion Fittings with Metal Compression Sleeves	28
Metal or Plastic Insert Fittings.....	29
Copper Crimp Ring.....	29
Stainless Steel Clamp	30
Stainless Steel Press Sleeve.....	30
Push Type Fittings.....	31

Standard Specifications for Fittings	32
ASTM F877: Standard Specification for Cross-Linked Polyethylene (PEX) Hot- and Cold-Water Distribution Systems	32
ASTM F1807: Standard Specification for Metal Insert Fittings Utilizing a Copper Crimp Ring for SDR9 Cross-Linked Polyethylene (PEX) Tubing and SDR 9 Polyethylene of Raised Temperature (PE-RT) Tubing.....	32
ASTM F1960: Standard Specification for Cold Expansion Fittings with PEX Reinforcing Rings for Use with Cross-Linked Polyethylene (PEX) Tubing	32
ASTM F2080: Standard Specification for Cold Expansion Fittings with Metal Compression Sleeves for Use with PEX Pipe.....	32
ASTM F2098: Standard Specification for Stainless Steel Clamps for Securing SDR9 Cross-Linked Polyethylene (PEX) Tubing to Metal Insert and Plastic Insert Fittings	33
ASTM F2159: Standard Specification for Plastic Insert Fittings Utilizing a Copper Crimp Ring for SDR9 Cross-Linked Polyethylene (PEX) Tubing and SDR9 Polyethylene of Raised Temperature (PE-RT) Tubing.....	33
ASTM F2434: Standard Specification for Metal Insert Fittings Utilizing a Copper Crimp Ring for SDR9 PEX Tubing and SDR9 PEX-AL-PEX Tubing.....	33
ASSE Standard 1061	34

Chapter 6 – TYPES OF PEX PLUMBING SYSTEMS 35

Trunk and Branch	36
Parallel	37
Zone (Zone and Multi-port Tee).....	38

Chapter 7 – DESIGN..... 39

Consult Local Codes.....	39
Optimize Home Designs	40
Select Piping System Design.....	41
General Rankings of the Systems for Key Factors.....	42
Example Layouts	43
Colonial Layout.....	44
Ranch Layout	47
Townhouse Layout	50
Condominium Layout.....	53
Performance Verification Laboratory Testing.....	56
Industry Technical Support.....	56
Plan Pipe Routing, Manifold/Multi-port Tee, and Valve Locations	56

Chapter 8 – PERFORMANCE DATA 61

System Performance Comparison.....	61
Test System Design and Set-up	62
Plumbing System Pressure and Flow Test Results.....	65

Wait Time for Hot Water	72
Test Summary	73
PEX Pipe Response to Surge Pressure (Water Hammer).....	74
PEX and Copper Pipe Flow Rates	75

Chapter 9 – INSTALLATION 77

Cross-Linked Polyethylene (PEX) Hot- and Cold-Water Distribution Systems and Service Lines	77
Important Notice.....	77
Revision Policy	78
Manual Content & Use.....	79
Other Uses of Cross-Linked Polyethylene (PEX) Tubing.....	79
Tubing Identification.....	80
Fitting Identification	81
Applicable Standards.....	81
Limitations on PEX Use	81
Designation Codes of ASTM F876	82
TUBING INSTALLATION PRACTICES.....	83
General Installation	83
Bending the Tubing.....	84
Handling and Storing Tubing and Fittings.....	84
TUBING SUPPORTS.....	85
Selection and Inspection	85
Support Spacing and Location	85
Horizontal Tubing Support Spacing.....	85
Expansion/Contraction of Tubing.....	86
Hydraulic Shock (Pressure Surge)	86
Parallel Water Distribution Manifold Plumbing (Parallel) Systems.....	87
Retro-Fit Installations	89
Thawing PEX Tubing Systems.....	89
Pressure Testing and Inspection of the Completed System.....	90
Disinfection of Potable Water Systems	90
Buried PEX Water Service Lines.....	91
Material	91
Fittings	91
Trench Preparation	91
Laying the Tubing	91
Penetrating Foundation or Basement Walls	92
Slab-on-Grade Installation.....	92
Laying and Supporting Tubing under Slab	92
Protection of Tubing and Fittings from UV Exposure after the Pour	92
Backfilling.....	93
Technical Data	93
Tubing Dimensions and Weights.....	93
Flow Rate and Velocity	94
Friction Losses.....	95
Pressure Loss and Flow Rate.....	96

Connection (Transition) to Other Piping Materials	97
Joining Procedures Utilizing Metallic or Polymer Insert Fittings .	98
Insert Fitting with a Black Copper Crimp Ring (ASTM F1807 or ASTM F2159).....	98
Making a Connection.....	98
Incorrect Connections	98
Tools and Rings	99
Joining Procedures Utilizing ASTM F1960 Fittings and PEX Rings.....	99
ASTM F1960 Connections, Helpful Hints.....	100
Tools	101
Joining Procedures Utilizing ASTM F2080 Fittings and Compression Sleeves	101
Summary	101
Procedure.....	101
Other Fitting Systems.....	102
Chapter 10 – TESTIMONIALS	103
Chapter 11 – OTHER APPLICATIONS	107
Radiant Heating and Cooling Systems	107
Municipal Water Service Pipe.....	108
Snow and Ice Melting Systems.....	108
Turf Conditioning.....	109
Geothermal Earth Energy Systems	109
Fire Suppression	110
Water Reuse/Reclaim	110
Appendix A – PERFORMANCE TEST SETUP AND DATA	111
Appendix B – INSTALLATION CHECKLIST .	121
Appendix C – RESOURCES	123
Articles and Reports.....	123
Manufacturers’ Information.....	128
Plastics Pipe Institute (PPI) Technical Publications.....	129
Glossary	131

List of Figures

Figure 5.1 – Cold Expansion Polymer Fitting with PEX Reinforced Ring	28
Figure 5.2 – Cold Expansion Metal Fitting with PEX Reinforced Ring.....	28
Figure 5.3 – Cold Expansion Fitting with Metal Compression Sleeve.....	28
Figure 5.4 – Metal Insert Fitting with Copper Crimp Ring	29
Figure 5.5 – Plastic Insert Fitting with Copper Crimp Ring.....	29
Figure 5.6 – Metal Insert Fitting with O-rings and Copper Crimp Ring.....	29
Figure 5.7 – Metal Insert Fitting with Stainless Steel Clamp Band	30
Figure 5.8 – Metal Insert Fitting with Stainless Steel Clamp Sleeve.....	30
Figure 5.9 – Metal Insert Fitting with Stainless Steel Press Sleeve	30
Figure 5.10 – Plastic Insert Fitting with Stainless Steel Press Sleeve.....	30
Figure 5.11 – Plastic Push Type Fitting	31
Figure 5.12 – Metal Push Type Fitting	31
Figure 6.1 – PEX Pipes in a Trunk and Branch System Design.....	36
Figure 6.2 – PEX Pipes in a Parallel Design	37
Figure 6.3 – PEX Pipes in a Zone Design	38
Figure 7.1 – Trunk and Branch Isometric Riser for the Colonial House.....	45
Figure 7.2 – Parallel Isometric Riser for the Colonial House	45
Figure 7.3 – Zone Isometric Riser for the Colonial House.....	46
Figure 7.4 – Trunk and Branch Isometric Riser for the Ranch House.....	48
Figure 7.5 – Parallel Isometric Riser for the Ranch House	48
Figure 7.6 – Zone Isometric Riser for the Ranch House.....	49
Figure 7.7 – Trunk and Branch Isometric Riser for the Townhouse.....	51
Figure 7.8 – Parallel Isometric Riser for the Townhouse.....	51
Figure 7.9 – Zone Isometric Riser for the Townhouse	52
Figure 7.10 – Trunk and Branch Isometric Riser for the Condominium	54
Figure 7.11 – Parallel Isometric Riser for the Condominium	54
Figure 7.12 – Zone Isometric Riser for the Condominium	55
Figure 8.1 – Fixture Layout for Laboratory Testing.....	63
Figure 8.2 – Laboratory Test Set-up with Five Outlets, Hot Water Tank, and T&B System	63
Figure 8.3 – The Test Fixture (Shower) with Flow and Pressure Sensors Installed	64
Figure 8.4 – Pressure Drop Comparison, 100’ Distance to TF	71
Figure 8.5 – Pressure Drop Comparison, 60’ Distance to TF	71
Figure 8.6 – Comparison of Hot Water Delivery Time	72
Figure 11.1 – Radiant Floor Heating Piping in a Residential Application	107
Figure 11.2 – Radiant Floor Heating Piping in a Commercial Application	107
Figure 11.3 – PEX Water Service.....	108
Figure 11.4 – Snow and Ice Melt Piping for a Driveway.....	108
Figure 11.5 – Snow and Ice Melting in a Commercial Application.....	109
Figure 11.6 – Turf Conditioning in a Stadium.....	109
Figure 11.7 – PEX Piping in a Geothermal Application.....	109
Figure 11.8 – Fire Sprinkler with PEX Piping.....	110
Figure 11.9 – Purple PEX for Water Reuse Applications.....	110
Figure A.1 – Water System Test Piping Layout – Trunk and Branch, 60’ to TF	111
Figure A.2 – Water System Test Piping Layout – Trunk and Branch, 100’ to TF..	112
Figure A.3 – Water System Test Piping Layout – Parallel, 60’ to TF.....	112
Figure A.4 – Water System Test Piping Layout – Parallel, 100’ to TF.....	113
Figure A.5 – Water System Test Piping Layout – Zone, 60’ to TF	113
Figure A.6 – Water System Test Piping Layout – Zone, 100’ to TF.....	114

List of Tables

TABLE R403.4.2 MAXIMUM RUN LENGTH (feet)	23
Table 7.1 – General Rankings of the System Characteristics.....	42
Table 7.2 – Fixture Count for each House Type.....	43
Table 7.3 – Fixture Summary for the Colonial House.....	44
Table 7.4 – Material Summary for the Colonial House	44
Table 7.5 – Fixture Summary for the Ranch House	47
Table 7.6 – Material Summary for the Ranch House	47
Table 7.7 – Fixture Summary for the Townhouse	50
Table 7.8 – Material Summary for the Townhouse	50
Table 7.9 – Fixture Summary for the Condominium.....	53
Table 7.10 – Material Summary for the Condominium.....	53
Table 7.11 – PEX Pipe Dimensions	55
Table 7.12 – Flow Velocity	58
Table 7.13 – Pressure Loss.....	59
Table 8.1 – Plumbing Fixtures Installed in the Test Plumbing System.....	64
Table 8.2 – Pressure and Flow Test Regime.....	65
Table 8.3 – TF Flow and Pressure Data for Each System	66
Table 8.4 – Simultaneous Flow Performance Data – 100’ Maximum Length, 40 psi Source Pressure	67
Table 8.5 – Simultaneous Flow Performance Data – 60’ Maximum Length, 40 psi Source Pressure.....	69
Table 8.6 – Performance Summary, 100’ Maximum Distance.....	73
Table 8.7 – First Peak Pressure for Each Piping Material and Flow Rate (Cold Water).....	74
Table 8.8 – First Peak Pressure for Each Piping Material and Flow Rate (Hot Water)	74
Table 8.9 – Flow Performance Data, PEX and Copper, 100’ Maximum Length, 40 psi Main Source Pressure	76
Table A.1 – Simultaneous Flow Performance Data – 100’ Maximum Length, 60 and 80 psi Source Pressure.....	114
Table A.2 – Simultaneous Flow Performance Data – 60’ Maximum Length, 60 and 80 psi Source Pressure.....	117



INTRODUCTION

The Second Edition

We are proud to publish the 2nd Edition of the PEX Design Guide. This edition includes many updates to reflect the increased usage of PEX systems in a variety of residential applications like water reuse and retrofit applications. New information has been added to almost every chapter including: standards updates in Chapter 3; updates to all applicable national plumbing, mechanical, and building codes in Chapter 4 including new green construction codes; updates to fitting systems in Chapter 5; and new design information on fixture flow rates and water hammer in Chapter 8. There have been many changes to national green building standards over the past few years. Many of those changes are captured throughout the document. In addition to the many updates, we are pleased to note the participation of third party certification bodies in the creation of this guide. It is believed that this new level of cooperation will make this guide easier to use and provide more value to installers and inspectors alike. Thank you for taking the time to download this PPI document.

Objective

This Design Guide provides the information and resources necessary to design and install cross-linked polyethylene (PEX) water supply systems in residential buildings. It includes comprehensive design concepts and installation guidelines to increase the acceptance and proper use of PEX. This document is targeted to meet the needs of home builders, designers, and trade contractors. Its purpose is to introduce potential users to PEX and to enable current users to optimize their PEX plumbing and fire sprinkler systems, and to minimize system costs. In addition, it will allow code inspectors and homeowners to become familiar with the applications, performance characteristics, and benefits of PEX water supply systems.



Background

Cross-linked polyethylene (PEX) is a high-temperature, flexible, polymer pipe. Cross-linking technology was first developed in Europe and has since come into use around the world for a variety of applications. PEX has a 30-year history of successful use in the European market with extensive testing for durability and material performance. It was first introduced in North America in 1984 where it has been primarily used for radiant floor heating, and more recently, for domestic water distribution systems. It is approved for potable hot and cold water supply systems as well as hydronic heating systems in all model plumbing and mechanical codes across the United States and Canada. In addition, PEX is approved for use in multi-family NFPA 13D sprinkler systems.

Not all plastics are the same, just as not all metals are the same. A result of modern polymer technology, PEX piping performs in ways that provide superior reliability, durability, and safety. Also, current testing requirements for PEX are much more stringent than any other time in history.

The PEX piping industry is highly regulated. Standards, specifications, and code requirements define tight material and production quality controls. Continuous-use temperature ratings as high as 200°F (93°C) are required as well as standardized chlorine resistance testing to ensure that the piping will withstand the most aggressive drinking water conditions. Nationally accredited, third-party certification agencies require strenuous quality control testing, including random plant inspections and annual monitoring testing.

There are numerous opportunities for more widespread use of PEX pipe in the U.S. residential market. The development of manifolds and parallel plumbing systems for flexible piping has helped to advance its use. All major residential building codes permit the use of PEX piping, but obstacles to its acceptance still remain. There is anecdotal and research information that shows:

- Some plumbers are reluctant to use PEX piping due to a lack of experience with installation methods and design requirements
- Some jurisdictions prohibit the use of PEX piping for water supply plumbing even though PEX pipe is approved for use in all model codes
- Codes were originally written for rigid trunk and branch systems; while they have now been amended to include PEX piping systems, they do not provide many system design details

Although these hurdles exist, the following are among the many benefits of PEX piping systems.

- **Ease of Installation** – PEX pipe uses mechanical connections eliminating the need for solders, flames, and chemicals. Its flexible nature allows it to bend around obstructions. Use of manifolds can speed installation and improve performance.
- **Corrosion Resistance** – PEX piping will not pit or stress corrode.
- **Scaling Resistance** – PEX pipe's smooth interior walls and chemical properties make it resistant to mineral build-up.
- **Cost Effectiveness** – PEX plumbing systems are less labor intensive and can optimize system performance.

- **Availability of Pipe Sizes** – PEX piping is available in a wide range of diameters.
- **Energy Efficiency** – PEX piping minimizes heat transmission through the pipe wall.
- **Resistance to Freeze Damage** – Under most circumstances, water in the pipe can be frozen and thawed without damaging the pipe.
- **Water Conservation** – Well designed PEX plumbing systems can reduce the wait time for hot water to reach the fixture.
- **Environmentally Sound** – PEX is an inert material and does not contain volatile organic compounds (VOCs).
- **Certification** – PEX pipes and fittings must meet strict performance requirements.

Although general research on hot water systems has been performed on various aspects of plumbing systems, a literature search by the Home Innovation Research Labs indicated that specific system design information for flexible water supply plumbing is sparse. Documents relied more on “standard practice” than on engineered or designed systems. Using these approaches often leads to system designs that either supply more water than is needed at the fixture, or do not take advantage of the characteristics of a flexible plumbing system to reduce cost and improve performance.

This Design Guide provides the information and resources necessary to design and install efficient and cost-effective PEX water supply systems in residential buildings. It illustrates various plumbing configurations for a variety of house types as well as installation guidelines for each method. Properly designed and installed PEX piping systems are beneficial for plumbing designers, installers, and homeowners.

Applications

PEX piping can be used in a wide variety of applications in residential construction. This Design Guide is focused on the design and installation of PEX hot and cold water supply systems, which can be used for both new construction and remodeling or retrofit projects.

Other applications for PEX are described in a separate section of this guide and include:

- Fire suppression systems (residential fire sprinklers)
- Municipal water service pipe in underground applications
- Radiant floor heating systems for suspended floor systems or in slab construction
- Snow and ice melt systems for sidewalks, driveways, entrances, and ramps
- Turf conditioning for greenhouses, golf courses, and sports field surfaces
- Water reuse and reclamation systems

Available in sizes from 1/4 to 4 inches, PEX piping can generally be installed in place of rigid piping on a size-for-size basis. Parallel installations with central manifolds can be used to balance pressures at the outlets and minimize hot water delivery wait time, reducing wasted water and energy. Manifolds can be installed that reduce the amount of piping and fittings, speed-up installation, and balance pressures throughout the system.

How to Use the Design Guide

This PEX Design Guide can be used by anyone considering the installation of a new or retrofit PEX piping system for residential plumbing applications. It can be used by the novice as an introduction to PEX piping or by the experienced plumber to optimize his/her approach. Building code officials can use this Guide as a consolidated source of information on the application of PEX piping in residential buildings. Builders can use this guide to learn about the advantages, installation issues, and expected performance of PEX plumbing systems for discussions with sales staff and homeowners.

Each section of this guide focuses on various aspects of using PEX piping.

- **Chapter 1 – Introduction:** Background information to educate the user about the history and uses of PEX piping
- **Chapter 2 – Advantages:** Various advantages to using PEX piping in residential buildings
- **Chapter 3 – Material Properties:** Unique properties of PEX piping
- **Chapter 4 – Joining Methods:** Explanations of the various types of fittings and their joining methods
- **Chapter 5 – Types of PEX Plumbing Systems:** Descriptions of the three types of PEX piping system designs
- **Chapter 6 – Code Acceptance:** Information on major plumbing codes and relevant jurisdictional code provisions for PEX piping
- **Chapter 7 – Design:** Designs and performance details of the three basic plumbing layouts for four common house configurations to assist in evaluating which system provides the best balance of performance, ease of installation, and cost for a particular house
- **Chapter 8 – Lab Testing and Performance Data:** System performance comparison of three plumbing systems
- **Chapter 9 – Installation:** Detailed instructions for installing PEX piping
- **Chapter 10 – Testimonials:** Quotes from plumbers and home builders on their experiences with PEX piping
- **Chapter 11 – Other Applications:** Other uses of PEX piping
- **Appendix A:** Additional lab testing data
- **Appendix B:** New Installation Checklist to aid plumbers with the process of installing PEX piping
- **Appendix C:** Resources for additional information beyond this Design Guide
- **Glossary:** List of terms and acronyms used in this Design Guide

There are three main ways to use this guide:

- **Introductory Overview:** The guide can be read in its entirety as an introduction for those who have little or no exposure to PEX piping.
- **Planning Tool:** The Code Acceptance and Design chapters, in particular, can be used to optimize system designs and building layouts during the planning stage while the home design is being finalized.
- **Reference Guide:** Certain sections can be extracted and read as needed. For example, plumbers may want to reference the Installation section, or building inspectors may want to reference the Code Acceptance section.

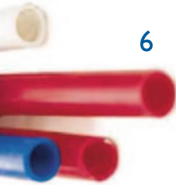



ADVANTAGES

Ease of Installation

The installation of PEX pipe is generally easier than rigid pipe. It is available in long coils which eliminates the need for coupling joints. Its flexible nature allows it to be bent gently around obstructions, minimizing the use of fittings. No solvent, chemical, or solder joining is required. The mechanical fittings are secure and reliable when installed properly. The pipe is lightweight, making it safe to transport and easy to handle. For a comparison of the installation of rigid metal pipe to PEX pipe, refer to the PATH Field Evaluation in Lincoln, Neb.¹

Durability

Based on extensive testing and material performance over the span of more than 40 years, PEX piping has proven to be a durable material that does not suffer from some of the historical problems associated with metallic piping, such as reduced interior dimension (occlusion), corrosion, electrolysis, filming, mineral build-up, and water velocity wear. PEX piping will typically expand if the system accidentally freezes, and return to its original size when the water thaws.

Cost Effectiveness

PEX plumbing systems have lower installation costs than rigid metallic plumbing systems. Installation time and labor required is greatly reduced. In service, the use of PEX systems can reduce energy and water use by delivering water to the fixtures faster and by reducing heat loss in the piping.

¹ The full PATH Field Evaluation report is available at <http://www.HomeInnovation.com>.



Energy Efficiency

PEX piping offers reduced heat loss and improved thermal characteristics when compared to metallic pipe. In addition, less energy is used by the water heater because of shorter delivery time for hot water with PEX parallel plumbing systems. For a definition of PEX parallel plumbing systems, see Chapter 6.²

Noise Reduction

When properly secured, PEX piping is quieter than rigid systems. It is inherently less noisy due to its flexibility and ability to absorb pressure surges (see Chapter 3).

Water Conservation

Properly designed PEX plumbing systems have the potential to conserve water (see Chapters 5 and 7). The flexibility of PEX allows it to bend around corners and run continuously, reducing the need for fittings; this allows downsizing the pipe diameter to 3/8-inch for certain fixtures. Parallel systems and 3/8-inch pipes minimize the time it takes hot water to reach the fixture. Lengthy delivery time for hot water represents a significant waste of water as well as energy; a problem exacerbated in larger homes.

In 2002, the Home Innovation Labs conducted software simulations and laboratory tests on a “typical” hot water system using a trunk and branch rigid pipe design and one that included a 3/8-inch diameter PEX parallel system. Results indicated that systems using shorter 3/8-inch runs with a parallel manifold reduced the wait time for hot water and wasted less water than longer runs of rigid pipe with numerous elbows and connections.³

Environmentally Sound

PEX is a modification or enhancement of high-density polyethylene, an economical and highly cost-effective construction piping material. Generally, as indicated by a peer reviewed life cycle inventory report⁴ manufacturing of plastic pipe consumes less energy than producing similar lengths of metallic pipe. The lighter weight of PEX compared to metallic piping helps to lower transportation costs and energy consumption, offering even greater benefit.

PEX pipes can be recycled as an inert filler material that can be incorporated into other polymers for specific applications. There is also reduced water use through faster delivery time. In addition, PEX pipe does not contain lead, harmful VOCs, or bisphenol A (BPA).

² Evaluation of Hot Water Distribution Systems by Numeric Simulation, 2004. Building Technology Center, Oak Ridge National Laboratory.

³ Performance Comparison of Residential Hot Water Systems, November 2002, NAHB Research Center report available at <http://www.HomeInnovation.com>.

⁴ The Life Cycle Inventory Report Peer-Reviewed Life Cycle Inventory for the Production and Use of Installed Residential Piping Systems for three House Layouts, February 3, 2011, commissioned by the Plastic Pipe and Fittings Association and prepared by Franklin Associates is available at http://www.ppfahome.org/pdf/Peer_Reviewed_Pipe_Use_Phase_Report_combined_Final.pdf.

Versatility

In addition to being used for domestic hot and cold water plumbing, PEX piping has numerous other applications because of its physical properties (flexibility, reliability, installation ease etc.) PEX lends itself to these and many other applications:

- Residential and commercial potable cold- and hot-water distribution systems
- Residential fire protection systems
- Hydronic radiant heating and cooling, using warm or chilled fluids
- Outdoor snow and ice melting
- Outdoor turf conditioning
- Ice surface piping
- Hot-water distribution piping
- Hot-water baseboard piping
- Warm- and hot-water radiator connection piping
- Potable water service pipes
- Geothermal ground loop heat exchangers
- Chilled water piping
- Specialized industrial and mining applications

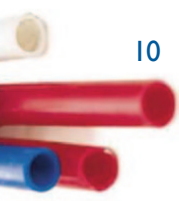



MATERIAL PROPERTIES

PEX is a material made up of molecules of high-density polyethylene (HDPE) that are permanently linked to each other by a process called crosslinking. Crosslinking makes PEX a “semi-thermoset” polymer, which gives it long-term stability.

Polyethylene can be crosslinked using several technologies. All methods induce links between the single strands of PE to form a dense network through radical reactions. The number of links between the strands determines the crosslink density and is an important factor in determining the physical properties of the material. The three most common methods of crosslinking polyethylene are as follows:

Peroxide – This method employs organic peroxides that when heated generate reactive free radicals that splice PE chains together. This is sometimes referred to as the PEX-a Process.

Silane – This method involves grafting a reactive silane molecule to the backbone of the polyethylene. This is sometimes referred to as the PEX-b Process.

Electron beam – This method involves subjecting a dose of high-energy electrons to the PE. This is sometimes referred to as the PEX-c Process.

PEX pipe produced by any of the three methods must meet the same qualification requirements as specified in the PEX standards. The letter designations are not related to any type of rating system.

Although the three methods of crosslinking produce slightly different pipe characteristics, all three are commonly used to manufacture approved PEX products. As required in any manufacturing process, procedures for each technology must be established and followed with good quality control checks in place to produce quality products.



For instance, ASTM Standard Specification F876 states, “This specification covers crosslinked polyethylene (PEX) tubing that is outside diameter controlled, made in standard thermoplastic tubing dimension ratios, and pressure rated for water at three temperatures. This specification covers one PEX tubing material in one standard dimension ratio and having pressure ratings for water of three temperatures. The pressure ratings decrease as the temperature is increased. PEX tubing shall be made from polyethylene compounds which have been crosslinked by peroxides, Azo compounds, or silane compounds in extrusion, or by electron beam after extrusion, or by other means such that the tubing meets the performance requirements. The following tests shall be performed: dimensions and tolerances; density; sustained pressure test; burst pressure; environmental stress cracking test; degree of crosslinking; stabilizer functionality; and oxidative stability in potable chlorinated water applications.”

Temperature and Pressure Capabilities

PEX piping meets all requirements for temperature and pressure capabilities in residential applications. Consensus standards published by ASTM International and Canadian Standards Association specify temperature and pressure capabilities of PEX systems, and components used in residential applications bear the appropriate test marking.

A pressure rating is the estimated maximum pressure that the medium in the pipe can exert continuously with a high degree of certainty that failure of the pipe will not occur. *Temperature/pressure ratings for plastic pipes are based on an extrapolated time-to-failure prediction as defined in ASTM Test Method D2837.* Pressure ratings for PEX pipes are derived from the recommended hydrostatic design basis (HDB) and hydrostatic design stress (HDS) values as issued by PPI. These recommended grades are listed in PPI Technical Report TR-4.

One example of these test requirements is the Hydrostatic Sustained Pressure Strength test: These laboratory tests are performed at several temperatures and are used to demonstrate the pressure ratings which will be marked on PEX pipes. These pressure ratings for water temperatures are 160 psig at 73.4°F and 100 psig at 180°F. Some PEX pipes are also pressure-rated for 80 psig at 200°F.

Another example of these test requirements is the excessive temperature and pressure test: In the event of a water heating system malfunction, PEX systems are designed to accommodate short-term conditions of 48 hours at 210°F and 150 psi until repairs can be made to the water heating system. The most commonly used Temperature & Pressure relief valves (T&P) activates (opens) at either of these temperature or pressure conditions. All PEX systems have been tested to withstand T&P activation for 30 days to ensure that safety requirements are met. As such, PEX systems DO NOT require the use of a special T&P valve.

Corrosion Resistance

PEX pipe will not pit or stress corrode. Corrosion, as an electrolytic process, requires the presence of electrically conductive materials – primarily lead, iron, steel and copper. PEX is a dielectric material, a non-conductor, and does not corrode like metal pipes. Independent testing of PEX pipe and fittings using aggressive potable water conditions demonstrated that neither the pipes nor the fittings suffered from pitting or corrosion. This testing utilized potable water with corrosive pH levels between 6.5 and 6.7, much lower and more aggressive than levels found in common water systems.

Corrosion factor adjustments, commonly used with metal piping systems, are not needed when sizing a PEX system.

A related aspect of corrosion in pipes is concerned with flow erosion. Flow erosion tests of PEX fittings were conducted by the PPI, and there was no weight loss. See *Erosion Study on Brass Insert Fittings Used in PEX Piping Systems*, PPI-TN-26 for discussion and results.

Erosion

PEX pipe has a smooth interior surface and can withstand high velocities. Under the test conditions reported in *PPI TN-26 Erosion Study on Brass Insert Fittings Used in PEX Piping Systems*, no detectable erosion of the pipe surface occurred at water velocities in excess of 12 ft/sec. Design velocities are generally restricted by factors other than the PEX pipe (i.e. valves, fittings).

Tuberculation

The potential for tuberculation of PEX pipe is minimal. Tuberculation typically occurs in response to the deposition of minerals onto the surface of the pipe and subsequent corrosive action with the base material of the pipe. PEX pipe has a smooth interior surface, which provides minimal opportunity for the precipitation of minerals such as calcium carbonate.

Lower Thermal Conductivity/Lower Specific Heat

PEX pipe reduces heat loss through the pipe wall, compared to metal pipes. This means that condensation is less likely to form on PEX pipes in humid environments, and less heat is lost to the environment in hot-water applications.

PEX tubing has a lower range of thermal conductivity, typically 60-70 times lower in comparison with metal plumbing pipes. According to a recent PPI Technical Report, the normalized thermal conductivity for PEX is 2.86 (BTU·in)/(ft²·hr·°F). Since the wall thickness of PEX is less than 1" and varies by its nominal size (SDR-9), the following table shows the R-value by nominal diameter:

Tubing size	1/2"	3/4"	1"	1-1/4"	1-1/2"	2"
R-value	.0277	.0383	.0494	.0604	.0715	.0932

Note: Normalized R-values are based on standardized material thickness of one inch.

Flexibility

The flexible nature of PEX allows it to be bent gently around obstructions and installed as one continuous run without fittings, if desired. Slight changes in direction are made easily by cold-bending the pipe by hand; snap-on bend supports to hold the pipe in this position are sometimes used in place of elbows. There is a predetermined minimum bend radius of a 90-degree change of direction without installing a fitting (reference manufacturer's installation instructions). Minimizing joints and connections can result in quicker installations, less potential for leaks at fittings, and less resistance by reducing pressure loss through fittings.

Noise and Water Hammer Resistance

As water flows through pipes, pressure in the system gives moving water energy, known as kinetic energy. Kinetic energy increases with the speed of water and also with the mass of water that is flowing. When the flow of water is suddenly stopped, such as when a valve or faucet is closed, this kinetic energy must be dissipated in the system, and a short-term surge in water pressure will result.

The ability of a plumbing pipe to dissipate energy due to surge in water pressure is based on the pipe's modulus of elasticity, a measure of material stiffness. A higher modulus of elasticity means the material is more rigid. Copper pipe is 180 times more rigid than PEX pipe.

The surge pressure that causes water hammer can produce instantaneous pressures of 300 to 400 psig, which can, over time, cause damage to rigid pipes, fittings, fixtures, and hot water tanks.

Ultimately, this means that with rigid piping systems, pressure surges can produce noticeable banging sounds as energy is dissipated, thus causing what is known as “water hammer.”

Note: Other audible “water hammer” noise can also be caused by a moving column of water cavitating as pressure waves reverberate within pipes. This noise is typically not related to excessive surge pressures, and is not damaging to plumbing system components. This effect may be more likely in low water-pressure systems. Even the most flexible pipe cannot prevent all noises in certain situations.

Testing was conducted at the Home Innovation Labs to measure actual pressure surges generated in piping systems of copper and PEX plumbing pipes in response to a quick-acting valve. Details of this study are found in Chapter 8.

In summary, the flexibility of PEX pipe allows the pipe itself to absorb energy from pressure surges and eliminate or reduce the occurrence of water hammer.

Resistance to Freeze Damage

PEX pipes are less susceptible to the effects of cold temperatures retaining their flexibility even below freezing. This flexibility means that if water-filled PEX piping freezes, the elasticity of the material allows it to expand without cracking or splitting, and then to return to its original size upon thawing. This applies when PEX pipes have room to expand evenly along their length, as is typical when installed within walls or ceilings. Water-filled PEX pipes, allowed to freeze inside a slab or highly compacted soil, may not be able to expand evenly and may suffer damage.

PEX Material Designation Code

As listed on page 12, ASTM F876 includes tests for many types of performance. Specifically, F876 has categories for PEX pipe performance in three key areas: chlorine resistance, UV resistance and hydrostatic design strength (HDS). Performance categories are defined in the “Material Designation Code,” which is required to be on the printline of PEX pipes. For detailed information about the PEX Material Designation Code see Chapter 9.

Resistance to Chlorine and Chloramines

The U.S. Environmental Protection Agency (EPA) recommends that all drinking water be disinfected, typically using free chlorine, chloramines, or other less common methods. Currently, the majority of potable drinking water in the United States and Canada is disinfected using free chlorine. The second most common method of disinfection is chloramines. For water treated with free chlorine or chloramines, the EPA sets a maximum disinfectant level of 4.0 parts per million (ppm) within the water distribution system.

To ensure the reliability of PEX piping systems in hot chlorinated water applications, it is a requirement of the PEX pipe product standard specification ASTM F876 that all PEX pipes intended for use with potable water have a minimum extrapolated lifetime of 50 years when tested in accordance with test method ASTM F2023: “*Standard Test Method for Evaluating the Oxidative Resistance of Cross-linked Polyethylene (PEX) Tubing and Systems to Hot Chlorinated Water.*”

All PEX pipe must be tested and certified by qualified third-party certification agencies to meet the requirements of ASTM F876, including chlorine resistance. The test conditions of ASTM F2023 require that the test fluid has a minimum oxidative reduction potential (ORP) of 825 mV. To produce test fluid with this high ORP, third-party test laboratories typically use reverse osmosis-purified water with a free chlorine concentration of 4.3 +/- 0.3 ppm (4.3 mg/L) and pH of 6.8 +/- 0.2, resulting in an ORP of 825 mV or higher. This represents a very aggressive water quality, which gives conservative results in terms of expected pipe lifetime. This test procedure is designed to extrapolate the life expectancy of a hot-water plumbing pipe when used at a domestic hot water temperature of 140°F and a pressure of 80 psi. Continuous recirculation, timed recirculation and traditional domestic conditions are evaluated by ASTM F2023. The minimum requirement applies to traditional domestic applications, while the other performance categories are also used in certain situations.

ASTM F876 has four categories representing various levels of chlorine resistance ranging from untested to 100% hot water recirculation, as listed in the Material Designation Code. See Chapter 9 for explanations of Material Designation Codes.

PEX piping systems use fittings that also must comply with ASTM standards, and are made from brass, copper, or high temperature engineered polymers that are also chlorine-resistant.

Regarding resistance to chloramines, a research project coordinated by the PPI⁶, examined the relative oxidative aggressiveness of the common potable water disinfectants free chlorine and chloramines on crosslinked polyethylene (PEX) pipes. According to the study, “Based on these results, it is the position of PPI BCD that chloramines are less aggressive than free chlorine to PEX pipes. Testing of oxidative resistance using free chlorine, in accordance with ASTM F2023, will provide a conservative estimate of the time-to-failure for PEX pipes when used with the disinfectant chloramines.”

In summary, PEX pipe has shown itself to be resistant to attack from chlorine and chloramines under a wide range of conditions, and has performed reliably in all regions of North America.

⁶ PPI Statement A: “Relative Oxidative Aggressiveness of Chloramines and Free Chlorine Disinfectants used in Treated Potable Water on Crosslinked Polyethylene (PEX) Pipe”

Ultraviolet (UV) Resistance

Like most plastics, the long-term performance of PEX will be affected by UV radiation from sunlight. Although most PEX pipes have some UV resistance, PEX pipes should not be stored outdoors where they are exposed to the sun. PEX pipes should not be installed outdoors, unless they are buried in earth or properly protected from UV exposure, either direct or indirect.

Indirect (diffused) and reflected sunlight also emit UV energy. If PEX will be exposed to sunlight continuously after installation, such as in an unfinished basement, cover the pipe with a UV-blocking sleeve or pipe insulation as approved by the pipe manufacturer.

Each PEX pipe manufacturer publishes a maximum recommended UV exposure time limit, based on the UV resistance of that pipe as determined in accordance with the stringent ASTM Test Method F2657 and the requirements published in ASTM F876. Central Arizona is used as the basis of the exposure time limits, as it represents the worst case North American location for UV energy. Exposed pipes are then re-tested for chlorine resistance in accordance with ASTM F2023 and must show no significant reduction in pipe lifetime.

ASTM F876 has four categories for UV resistance, representing various levels of UV resistance ranging from untested: to 6 months continuous exposure, as listed in the Material Designation Code. See Chapter 9 for explanations of Material Designation Codes. Do not allow PEX pipes to be over-exposed beyond these limits.

- “Ensure that accumulative exposure time to sunlight during storage and installation does not exceed the maximum recommended UV exposure limit as indicated by the manufacturer.”

Caution

- Do not store PEX pipes outdoors.
- Keep PEX pipes in original packaging until time of installation.
- Ensure that exposure to sunlight during installation does not exceed the maximum recommended UV exposure time as recommended by the manufacturer.

Safe for Drinking Water

Since PEX piping is used to transport potable water, it must comply with federal regulations for public safety. PEX materials are inert (not chemically reactive) and cannot contaminate the potable water passing through them. The fittings are mechanical and do not require the use of solvents or chemicals that might leach into the water when the system is first used.

Testing and certification must comply with NSF/ANSI Standard 61: *Drinking Water System Components - Health Effects*, and NSF/ANSI Standard 14: *Plastic Pipe System Components and Related Materials*. The primary focus of Standard 61 is to establish minimum health effect requirements for chemical contaminants and impurities that are indirectly imparted into drinking water from products, components, and materials used in potable water systems.

PEX piping systems for potable water are tested at water pH levels from 5.0 to 10.0, both excessive acidity and alkalinity, beyond levels encountered in potable water systems, and at both cold and hot water temperatures.

PEX pipes do not contain lead⁷, harmful volatile organic compounds (VOCs) or BPA (Bisphenol A).

⁷ NSF/ANSI Standard 61 – Annex G is used to determine product compliance with the ≤0.25% percent maximum weighted average lead content requirement of certain state and federal regulations. PEX pipes must comply with Annex G to be lead-free.





4 CODE ACCEPTANCE

PEX plumbing systems are recognized in all major building model codes and are commonly used for hot- and cold-water distribution applications, water service lines, fire protection and radiant floor heating systems. The following is a summary of relevant model code requirements which specifically pertain to PEX and plastic pipe and fittings used for domestic water supply.

The user must determine which codes are applicable to his/her specific project, and also must ensure compliance with all local, state, and federal codes, regulations, and standards. Codes are constantly reviewed and updated. PEX water supply piping has been adopted in the model codes since 1993.

International Residential Code (IRC-2012)

P2605.1 General. PEX tubing shall be supported at distances not to exceed those indicated in Table 2605.1. For PEX, maximum horizontal support spacing is 32 inches, and maximum vertical support spacing is 10 feet (mid-story guide for sizes 2 inches and smaller). Piping shall be supported to ensure alignment and prevent sagging, and allow movement associated with the expansion and contraction of PEX tubing. Hangers and anchors shall be of sufficient strength to support piping and weight of its contents.

P2609.3 Plastic Pipe, Fittings, and Components. All plastic pipe, fittings, and components shall be third-party certified as conforming to NSF 14.

P2903.7 Size of Water-Service Mains, Branch Mains and Risers. The size of each water distribution system shall be determined according to design methods conforming to acceptable engineering practice, such as those methods in Appendix P (IRC 2012) and shall be approved by code official.

P2903.8 Gridded and Parallel Water-Distribution System Manifolds. Hot and cold parallel water-distribution system manifolds with individual distribution lines to each fixture or fixture fitting shall be sized and installed in accordance with Sections P2903.8.1 through P2903.8.6.

- **P2903.8.1 Sizing of Manifolds.** Manifolds shall be sized in accordance with Table P2903.8.1. Total gallons per minute is the demand for all outlets.
- **P2903.8.2 Minimum Size.** The maximum developed length of individual distribution lines shall be 60 feet (18.2 m) with 40 psi minimum at water meter in order to utilize 3/8" tubing for individual distribution lines. Fixtures shall be supplied with the tubing size specified by manufacturer. If water heater is fed from the end of a cold water manifold, the manifold shall be one size larger than the water heater feed.
- **P2903.8.3 Orientation.** Manifolds shall be permitted to be installed in a horizontal or vertical position.
- **P2903.8.4 Support and Protection.** Plastic piping bundles shall be secured in accordance with manufacturer's installation instructions and supported in accordance Section P2605. Bundles that have a change in direction equal to or greater than 45 degrees shall be protected from chaffing at the point of contact with framing members by sleeving or wrapping.
- **P2903.8.5 Valving.** Installed fixture valves shall be located at either the fixture or manifold. If installed at manifold, valves shall be labeled indicating the fixture served.

P2903.9.4 Valve Requirements. Valves shall be approved and compatible with the type of piping material installed in the system. Valves intended to supply drinking water shall meet the requirements of NSF 61.

P2904 Dwelling Unit Fire Sprinkler Systems, P2904.1 General. Residential fire sprinkler systems shall be designed and installed in accordance with NFPA 13D. A multi-purpose fire sprinkler system shall supply domestic water to both fire sprinklers and plumbing fixtures.

P2904.2 Sprinklers. Sprinklers shall be new listed residential sprinklers and installed in accordance with manufacturer's installation instructions and in compliance with P2904.2.1 thru P2904.2.4.

P2904.3 Sprinkler Piping System. Sprinkler piping shall be supported in accordance with the requirements for cold water distribution piping. For multi-purpose piping systems, the sprinkler piping shall connect to and be a part of the cold water distribution piping system.

- **P2904.3.1 Non-metallic pipe and tubing, P2904.3.1.1 Non-metallic Pipe protection.** Non-metallic pipe and tubing, such as PEX, shall be listed for use in residential fire sprinkler systems. PEX tubing shall be protected from exposure to the living space by a layer of not less than 3/8 inch thick gypsum wallboard, 1/2 inch thick plywood or other material having a 15 minute fire rating.

P2904.4 Determining System Design Flow. The flow for sizing the sprinkler piping system shall be based on the flow rating of each sprinkler in accordance with Section P2904.4.1 and the calculation in accordance with Section P2904.4.2.

P2904.5 Water Supply. The water supply shall provide the required not less than the required design flow rate for sprinklers in accordance with Section P2904.4.2 at a pressure not less than that used to comply with Section P2904.6

P2904.6 Pipe Sizing. Sprinkler piping shall be sized for the flow required by Section P2904.4.2. Flow required to supply plumbing fixtures is not required to be added to the sprinkler design flow.

P2905.4 Water Service Pipe. Water service pipe shall conform to NSF 61 and one of the standards listed in Table P2905.4

P2905.5 Water-Distribution Pipe. Water distribution piping within the building shall conform to NSF 61 and one of the standards listed in Table P2905.4.

P2905.9 Plastic Pipe Joints. Joints in PEX tubing shall be made with approved fittings.

- **P2905.9.1.4 Cross-Linked Polyethylene Plastic (PEX).** Joints between PEX plastic tubing and fittings shall comply with Section P2905.9.1.4.1 or Section P2905.1.4.2.
- **P2905.9.1.4.2 Mechanical Joints.** Mechanical joints shall be installed in accordance with manufacturer's instructions. Fittings for PEX plastic tubing as described in ASTM F 1807, ASTM F 1960, ASTM F 2080, ASTM F2098, ASTM F2434 and ASTM F 2159, shall be installed in accordance with manufacturer's instructions. PEX tubing shall be factory marked with applicable fitting standards.

P2905.17 Joints Between Different Materials. Joints shall be installed in accordance with the manufacturer's instructions.

- **P2905.17.2 Plastic Pipe or Tubing to Other Pipe Materials.** Joints between different types of plastic pipe or between plastic pipe and other piping material shall be made with an approved adapter fitting.

International Plumbing Code (IPC 2012)

601.3 Existing Piping Used for Grounding. Existing metallic water service piping used for electrical grounding shall not be replaced with nonmetallic pipe or tubing until other approved means of grounding is provided.

603.1 Size of Water Service Pipe. The water service pipe shall be sized to supply water to the structure in quantities and at the pressures required in this code. The water service pipe shall be not less than $\frac{3}{4}$ inch in diameter.

604.3 Water Distribution System Design Criteria. Pipe sizes shall be selected under conditions of peak demand and shall be no less than the minimum flow shown in Table 604.3

- **604.10.1 Manifold Sizing.** Hot and cold water manifolds shall be sized in accordance with Table 604.10.1. The total gallons per minute is the demand of all outlets supplied.

605.3 Water Service Pipe. Water service pipe shall conform to NSF 61 and to one of the standards listed in Table 605.3 (ASTM F 876, ASTM F 877, AWWA C904 and CSA-B137.5).

605.4 Water Distribution Pipe. Water distribution pipe shall conform to NSF 61 and to one of the standards listed in Table 605.4 (ASTM F876, ASTM F 877, and CSA-B137.5).

605.5 Fittings. Pipe fittings shall be approved for installation with the piping material installed and shall conform to one of the standards listed in Table 605.5. Pipe fittings utilized in water supply systems shall also comply with NSF 61.

605.17 Cross-Linked Polyethylene Plastic. Joints between cross-linked polyethylene plastic tubing or fittings shall comply with Sections 605.17.1 and 605.17.2.

- **605.17.2 Mechanical Joints.** Mechanical joints shall be installed in accordance with manufacturer's instructions. Fittings for PEX tubing shall comply with the applicable standards listed in Table 605.5.

605.24 Joints Between Different Materials. Joints shall be installed in accordance with the manufacturer's instructions.

- **605.24.2 Plastic Pipe or Tubing to Other Piping Material.** Joints between different grades of plastic pipe or between plastic pipe and other piping material shall be made with an approved adapter fitting.

International Mechanical Code (IMC 2012)

305 Piping Support. Pipe hangers and supports shall have sufficient strength to withstand all anticipated static and specified dynamic loading conditions associated with the intended use. Pipe hangers and supports in direct contact with piping shall be of approved materials that are compatible with the piping and will not promote galvanic action.

305.4 Interval of Support. Piping shall be supported at distances not exceeding the spacing specified in Table 305.4 or in accordance with MSS SP-69; Horizontal spacing for PEX is 32 inches and 10 feet with mid-story guide for vertical support.

1201 General. Potable cold and hot water distribution systems shall be installed in accordance with the International Plumbing Code (IPC).

International Energy Conservation Code (IECC 2012)

R403.4.1 Circulating Hot Water Systems. Circulating hot water systems shall be provided with an automatic or readily accessible manual switch that can turn off the hot water circulating pump when the system is not in use.

R403.4.2 Hot Water Pipe Insulation. Insulation for hot water pipe with a minimum thermal resistance (R-value) of R-3 shall be applied to the following:

1. Piping larger than $\frac{3}{4}$ inch nominal diameter
2. Piping serving more than one dwelling unit
3. Piping from water heater to kitchen outlets
4. Piping located outside the conditioned space
5. Piping from the water heater to a distribution manifold

6. Piping located under a floor slab
7. Buried pipe
8. Supply and return piping in a recirculation system other than demand recirculation systems
9. Piping with run lengths greater than the maximum run lengths for the nominal pipe diameter given in Table R403.4.2⁸.

Nominal Pipe Diameter of Largest Diameter Pipe in the Run (inch)	3/8	1/2	3/4	> 3/4
Maximum Run Length	30	20	10	5

For SI: 1 inch = 25.4 mm, 1 foot = 304.8 mm.

^aTotal length of all piping from the distribution manifold or the recirculation loop to a point of use.

Uniform Plumbing Code (UPC-2012)

312.0 Protection of Piping.

312.9 Steel Nail Plates. PEX piping penetrating framing members to within 1 inch of the exposed framing shall be protected by steel nail plates not less than No. 18 gauge in thickness.

313.0 Hangers and Supports.

313.1 Suspended Piping. Suspended piping shall be supported at intervals not to exceed those shown in Table 313.1.

313.2 Piping Support. Piping shall be supported in a manner as to maintain its alignment and prevent sagging.

604.0 Materials.

604.1 Pipe, Tube, and Fittings. PEX pipe, tube, fittings used in potable water systems intended to supply drinking water shall be in accordance with the requirements in NSF 61. PEX materials for building water piping and building supply piping shall comply with the PEX standards referenced in Table 604.1

604.9 Plastic Materials (Exception). Where a grounding system acceptable to the Authority Having Jurisdiction is installed, inspected, and approved, metallic pipe shall be permitted to be replaced with PEX pipe. Plastic materials for building supply piping outside underground shall have a blue insulated copper tracer wire or other approved conductor installed adjacent to the PEX pipe. Access shall be provided to the tracer wire or the tracer wire shall terminate aboveground at each end of the nonmetallic piping. The tracer wire size shall be not less than 18 AWG and the insulation type shall be suitable for direct burial.

604.13 Water Heater Connectors. PEX shall not be installed within the first 18 inches (457 mm) of piping connected to a water heater.

⁸IECC 2012.

605.10 PEX Tubing and Joints. PEX tubing and fitting joining methods shall be installed in accordance with the manufacturer's instructions and shall comply with Section 605.10.1 and Section 605.10.2.

- **605.10.1 Fittings.** Fittings for PEX tubing shall comply with the applicable standards referenced in Table 604.1. PEX tubing in accordance with ASTM F 876 shall be marked with the applicable standard designation for the fittings specified for use with the tubing.
- **605.10.2 Mechanical Joints.** Mechanical joints shall be installed in accordance with manufacturer's installation instructions.

605.17.2 Plastic Pipe to Other Materials. Where connecting PEX pipe to other types of piping, approved types of adapter or transition fittings designed for the specific transition intended shall be used.

Green Plumbing & Mechanical Code Supplement (IAPMO 2010)

502.1 Gray Water Systems. Refer to the provisions in Chapter 5 for construction, alteration and repair of gray water systems.

602.0 Service Hot Water – Low-Rise Residential Buildings, 602.1 General. The service water heating system for single-family houses, multi-family structures of three stories or fewer above grade and modular houses shall be in accordance with Section 602.2 through Section 602.5.

602.3 Recirculation Systems. Circulating hot water systems shall be arranged so that circulating pump(s) can be turned off when hot water system is not in operation. Circulation pump shall not operate continuously, be controlled by a timer or have a pump initiated by water temperature. Circulation pump shall initiate operation shortly before hot water is desired at a fixture. Systems with multiple recirculation zones shall be balanced to uniformly distribute hot water or operate with a pump for each zone.

602.5 Insulation. Hot water supply and return piping shall be thermally insulated. Wall thickness of insulation shall be equal to the diameter of pipe up to 2 inches and no less than 2 inches for piping larger than 2 inches. The conductivity of insulation shall be less than or equal to 0.28 [Btu*in/(h*sqt*°F)]. See Section 602.5 for further clarification and exceptions.

602.7.1 Central Core/Zone. Central core and zone plumbing system hot water distribution line volume to each qualified fixture shall not exceed a volume of 32 ounces.

602.7.2 Central Manifold. Central manifold, parallel piping or parallel hot-water plumbing systems, including the supply line from hot water source to the manifold, the internal volume of manifold and the lines to each qualified fixture shall not exceed a volume of 32 ounces.

602.7.3 Recirculation Loop. Residential hot water recirculation systems are limited to those that utilize on-demand activation of the circulating pump.

National Standard Plumbing Code (NSPC 2009)

3.4.1. Plastic Piping. Plastic piping materials used for the conveyance of potable water shall comply with NSF 14 and be marked accordingly.

3.4.2. Water Service Piping. Water service piping to the point of entrance into the building shall be of materials listed in Table 3.4, and shall be water pressure rated for not less than 160 psig at 73°F. Table 3.4: PEX Plastic Water Distribution Systems (ASTM F 877 with ASTM F 1807, F 1960, or F 2098 Fittings)

3.4.3. Water Distribution Piping. Water piping for distribution of hot and cold water within buildings shall be of materials listed in Table 3.4, and shall be water pressure rated for not less than 100 psig at 180°F and 160 psig at 73°F. Plastic piping used for hot water distribution shall be installed in accordance with requirements of Section 10.15.8.

3.4.4 Fittings. Fittings for water supply piping shall be compatible with the pipe material used.

8.7 Support of Plastic Pipe. Horizontal support spacing shall be based pipe schedule, wall thickness, pipe size, operating conditions and any concentrated loads. Vertical pipe shall be supported at each story and intermediate supports shall be provided to maintain alignment and stability. All piping shall be supported at changes of direction or elevation. Supports shall allow for free movement while not distorting, compressing or cutting the pipe. Provisions shall be made for expansion and contraction of the piping

10.5.9 Protection from Fire Systems. Backflow preventers shall not be required in multi-purpose or network residential sprinkler systems that supply both plumbing fixtures and residential fire sprinklers in accordance with NFPA 13D. The piping in such systems shall be approved for potable water.

10.15.8 Plastic Piping. Plastic piping used for hot-water distribution shall conform to the requirements of Section 3.4 and Table 3.4. Piping shall be water pressure rated for not less than 100 psi at 180°F. NOTE: The working pressure rating for certain approved plastic piping materials varies depending on pipe size, pipe schedule, and methods of joining. Plastic pipe or tube shall not be used downstream from instantaneous water heaters, immersion water heaters or other heaters not having approved temperature safety devices. Piping within 6 inches of flue or vent connectors shall be approved metallic pipe or tube. Normal operating pressure in water distribution piping systems utilizing approved plastic pipe or tube for hot-water distribution shall not be more than 80 psi.

National Plumbing Code of Canada (NPCC 2010)

2.3.4.4.1 Support for Vertical Piping. PEX piping shall be supported at its base and at floor level of alternate stories.

2.3.4.5. Support for Horizontal Piping.

1. Horizontal piping that is inside a building shall be braced to prevent swaying, buckling and to control the effects of thrusts.
2. Horizontal piping shall be supported as stated in Table 2.3.4.5; PEX = 0.8m
4. Where PEX plastic pipe is installed, hangers shall not compress, cut or abrade the pipe.

2.3.4.6 Support for Underground Horizontal Piping

1. Horizontal piping that is underground shall be supported on a base that is firm and continuous under the entire run of pipe.
2. Horizontal piping installed underground that is not supported as described in Sentence (1) may be installed using hangers fixed to a foundation or structural slab provided that the hangers are capable of maintaining alignment, and supporting the weight of pipe and its contents.

2.3.6.5 Air Pressure Tests

1. Air pressure tests shall be conducted in accordance with the manufacturer's instructions for each piping material to a minimum test pressure of 35 kPa and 15 minutes without a drop in pressure.

2.6.1.1 Design

1. Every fixture supplied with separate hot and cold water controls shall have the hot water control on the left and the cold on the right.
2. In a hot water distribution system of a developed length of more than 30 m or supplying more than 4 stories, the water temperature shall be maintained by recirculation or a self-regulating heat tracing system.

2.6.3.2 Design, Fabrication & Installation

1. Every water distribution system shall be designed to provide peak demand flow when the flow pressures at the supply openings conform to the plumbing supply fitting manufacturer's specifications and NPCC 2010 Division B.
2. Potable water systems shall be designed, fabricated and installed in accordance with good engineering practice, such as that described in the ASHRAE Handbooks and ASPE Data Books
3. In one- and two-family dwelling units and manufactured homes, multi-purpose systems that combine potable water systems and residential fire sprinkler systems shall be designed, fabricated and installed in accordance with NFPA 13D, "Installation of Sprinkler Systems in One- and Two-Family Dwellings and Manufactured Homes."



JOINING METHODS

There are several types of joining methods or fittings used with PEX plumbing systems. All are mechanical fittings that are either directional or transitional. PEX piping cannot be joined by solvent cementing.

Most PEX piping manufacturers have their own mechanical fitting system. The method of connection should comply with the manufacturer's recommendations and instructions. Fittings are regulated to comply with performance and material criteria from recognized standards. They should be marked by a certified third-party agency such as NSF, IAPMO, CSA, ICC, UL or other third-party testing and listing agency.

Not all fittings are applicable with all PEX pipe. Consult your manufacturer for acceptable methods.

The most common types of fitting systems used are shown in the following pages.



Cold Expansion Fittings with PEX Reinforced Rings

This type of fitting requires that the PEX piping, with a reinforcing PEX ring placed over the end of the pipe, is expanded before the fitting is inserted into the pipe end. The expanded pipe end is allowed to retract onto the fitting to form the seal—the “memory” of the pipe allows it to tighten over the fitting. An expander tool is required to expand the pipe and the PEX ring together. ASTM F1960 is applicable to fittings that use a PEX reinforcing ring.



Figure 5.1 – Cold Expansion Polymer Fitting with PEX Reinforced Ring

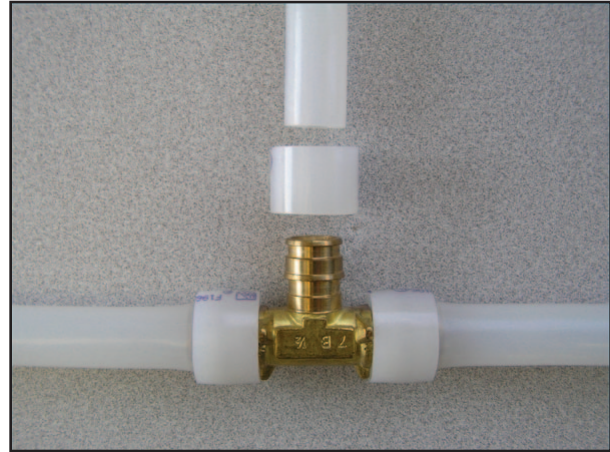

Figure 5.2 – Cold Expansion Metal Fitting with PEX Reinforced Ring

Cold Expansion Fittings with Metal Compression Sleeves

This type of fitting requires that the PEX piping is expanded before it is placed over the oversized fitting. The pipe shrinks down over the fitting insert, then a metal compression sleeve is pulled over the connection, compressing the pipe over the fitting. A tool is required to expand the pipe and to pull the sleeve over the pipe. ASTM F2080 is applicable to cold expansion fittings that use a metal compression sleeve.



Figure 5.3 – Cold Expansion Fitting with Metal Compression Sleeve

Metal or Plastic Insert Fittings

This type of fitting uses a metal crimp ring that is compressed around the PEX piping to secure it to the fitting. The crimp ring can be copper or stainless steel. Fittings can be made of copper, brass, bronze, or plastic. The fitting will typically have a barbed or ribbed annular end.

The PEX pipe slides over the barbed or ribbed annular section. Prior to making the connection, the metal crimp ring is slid over the PEX piping and away from the end of the pipe. The piping is pushed over the fitting, the crimp ring is slid down over that section and aligned over the fitting ribs, and a tool is used to compress the crimp ring around the assembly.

Copper Crimp Ring

The copper ring is crimped equally around the fitting. The go-no-go gauge ensures a proper crimp. Some manufacturers use o-rings on their metal fittings to make the seal with the pipe. ASTM F1807 is the applicable standard for metal insert fittings. ASTM F2159 is the applicable standard for plastic fittings. ASTM F2434 is the applicable standard for metal insert fittings with o-rings.

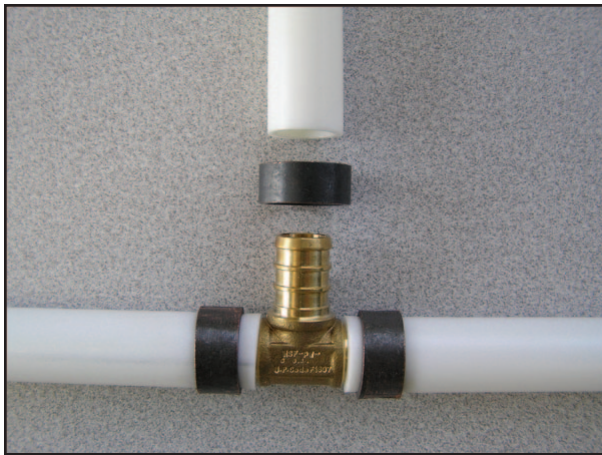

Figure 5.4 – Metal Insert Fitting with Copper Crimp Ring



Figure 5.5 – Plastic Insert Fitting with Copper Crimp Ring

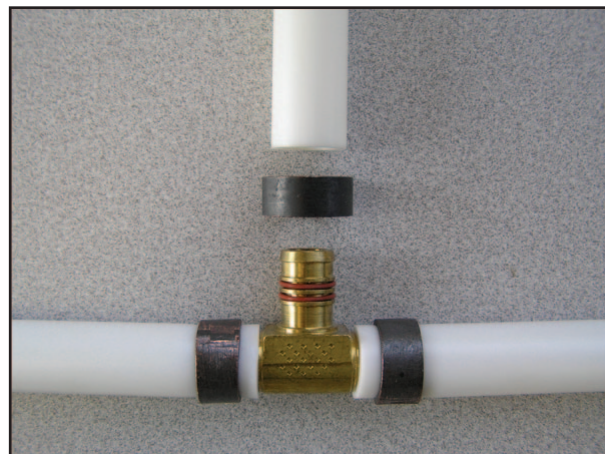

Figure 5.6 – Metal Insert Fitting with O-rings and Copper Crimp Ring

Stainless Steel Clamp

The stainless steel ring is crimped using a ratcheting tool, which only releases once a proper crimp is achieved. ASTM F2098 is the applicable standard for stainless steel clamps as shown in Figure 5.7.



Figure 5.7 – Metal Insert Fitting with Stainless Steel Clamp Band

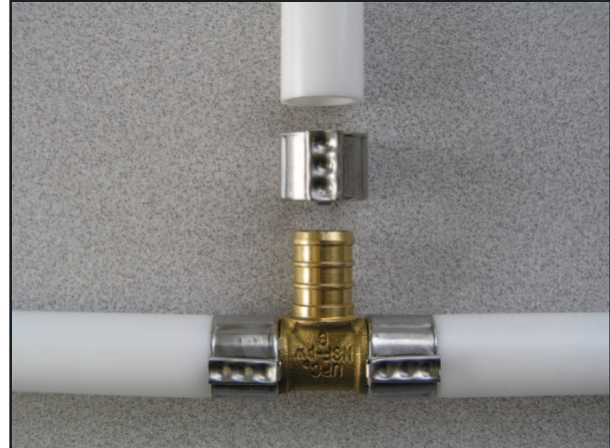

Figure 5.8 – Metal Insert Fitting with Stainless Steel Clamp Sleeve

Stainless Steel Press Sleeve

This type of fitting is made of metal and uses a press sleeve or cap to secure the PEX pipe to the fitting. These fittings have ribbed annular ends that are inserted into the PEX pipe. A sleeve or cap slides over the outer part of the piping and the fitting is inserted into the pipe. The pipe must be fully inserted. A press tool is used to make the final connection. It is important that the appropriate tool is used per manufacturer's instructions.



Figure 5.9 – Metal Insert Fitting with Stainless Steel Press Sleeve

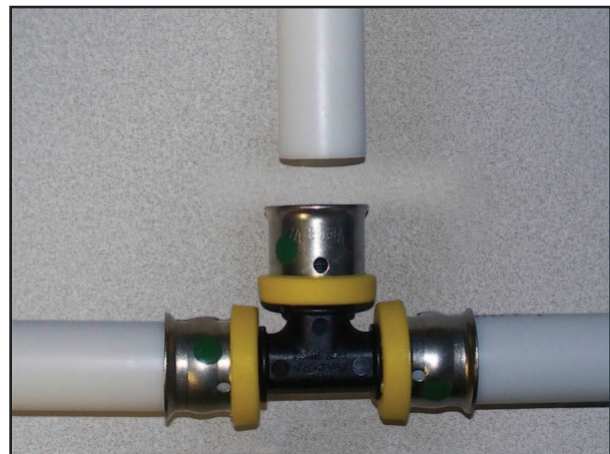

Figure 5.10 – Plastic Insert Fitting with Stainless Steel Press Sleeve

Push Type Fittings

This type of fitting uses an interlocking mechanism to connect the PEX pipe to the fitting. The pipe is inserted, or pushed, into the fitting, and locked into place with a fastening device that keeps the pipe from being backed-out or disconnected. Push type fittings typically use some type of o-ring or gasket to form a seal around the PEX pipe. A support liner is inserted into the pipe, and a fastening system with a locking component, such as a snap ring or twist collar, is used to ensure that the connection remains permanent. ASSE 1061 is the applicable standard for push type fittings.

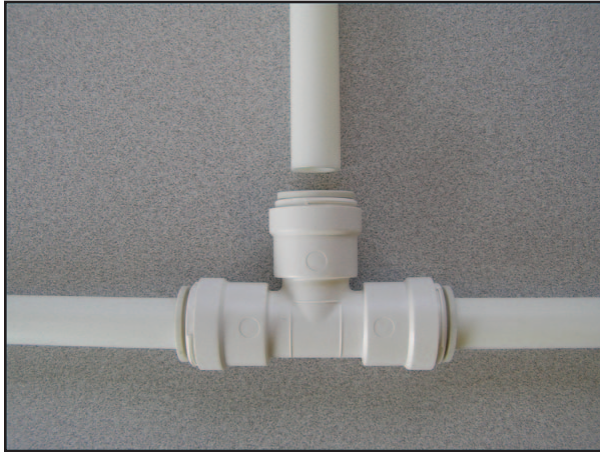

Figure 5.11 – Plastic Push Type Fitting



Figure 5.12 – Metal Push Type Fitting

Standard Specifications for Fittings

Fittings are categorized in accordance with ASTM⁹, or ASSE specifications, as follows:

ASTM F877: Standard Specification for Cross-Linked Polyethylene (PEX) Hot- and Cold-Water Distribution Systems

This specification covers requirements, test methods, and marking requirements for system components when tested with nominal SDR9 crosslinked polyethylene tubing as a system. Systems are intended for 100 psi (0.69 MPa) water service up to and including a maximum working temperature of 180°F (82°C). Requirements and test methods are included for materials, workmanship, dimensions and tolerances, burst pressure, sustained pressure, excessive temperature and pressure, and thermo-cycling tests. The components covered by this specification are intended for use in residential and commercial, hot and cold, potable water distribution systems or other applications such as municipal water service lines, radiant panel heating systems, hydronic baseboard heating systems, snow and ice melting systems, and building services pipe.

ASTM F1807: Standard Specification for Metal Insert Fittings Utilizing a Copper Crimp Ring for SDR9 Cross-Linked Polyethylene (PEX) Tubing and SDR 9 Polyethylene of Raised Temperature (PE-RT) Tubing

This specification covers metal insert fittings and copper crimp rings for use with PEX tubing that meet requirements in ASTM F876 and F877 and for use with raised temperature (PE-RT) tubing that meets the requirements of in ASTM F2623 and F2769. These fittings are intended for use in 100 psi (690 kPa) cold- and hot-water distribution systems operating at temperatures up to and including 180°F (82°C). Requirements for materials, workmanship, dimensions, and markings to be used on fittings and rings are also included. Size range is 3/8 to 2 inches.

ASTM F1960: Standard Specification for Cold Expansion Fittings with PEX Reinforcing Rings for Use with Cross-Linked Polyethylene (PEX) Tubing

This specification covers cold expansion fittings and PEX reinforcing rings for use with PEX plastic tubing that meet requirements of ASTM F876 and F877. These fittings are intended for use in 100 psi (690 kPa) cold- and hot-water distribution systems operating at temperatures up to and including 180°F (82°C). The system is comprised of a PEX reinforcing ring and a cold expansion fitting. Included are requirements for materials, workmanship, dimensions, and markings to be used on fitting components. Size range is 3/8 to 2 inches.

ASTM F2080: Standard Specification for Cold Expansion Fittings with Metal Compression Sleeves for Use with PEX Pipe

This specification covers cold-expansion fittings using metal compression sleeves for use with PEX plastic pipe that meet requirements of ASTM F876 and F877, whereby the PEX pipe is cold-expanded before fitting assembly. These cold expansion fittings and metal compression sleeves are intended for use in residential and commercial, hot and cold, potable water

⁹ ASTM Standard Titles and Scopes were extracted, with permission, from [ASTM F877, ASTM F1807, ASTM F1960, ASTM F2080, ASTM F2098, ASTM 2159, and ASTM F2434], copyright ASTM International, 100 Barr Harbor Drive, West Conshohocken, PA 19428. A copy of the complete standard may be purchased from ASTM International, www.astm.org.

distribution systems, with continuous operation at pressures up to and including 100 psi (690 kPa), and at temperatures up to and including 180°F (82°C). Included in the specification are requirements for materials, workmanship, dimensions, and markings to be used on fittings and compression sleeves. Performance requirements are as referenced in ASTM F877. Size range is 3/8 to 2 inches.

ASTM F2098: Standard Specification for Stainless Steel Clamps for Securing SDR9 Cross-Linked Polyethylene (PEX) Tubing to Metal Insert and Plastic Insert Fittings

This specification covers stainless steel clamps for use with four sizes of insert fittings that comply with F1807, and cross-linked polyethylene (PEX) plastic tubing that complies with F876 or F877. These clamps are intended as an alternative to the copper-alloy crimp-rings of Specifications F1807 or F2159 for use in 100 psi (689.5 kPa) cold- and hot-water distribution systems operating at temperatures up to and including 180°F (82°C). Included are requirements for materials, workmanship, dimensions, and marking of the stainless steel clamps; requirements for deforming the clamps, which apply to assemblies of PEX tubing and Specifications F1807 and F2159, insert fittings secured with deformed clamps per this specification.

ASTM F2159: Standard Specification for Plastic Insert Fittings Utilizing a Copper Crimp Ring for SDR9 Cross-Linked Polyethylene (PEX) Tubing and SDR9 Polyethylene of Raised Temperature (PE-RT) Tubing

This specification covers plastic insert fittings and copper crimp rings for use with PEX pipe that meets requirements in ASTM F876 and F877 and for use with raised temperature (PE-RT) tubing that meets the requirements of in ASTM F2623 and F2769. It establishes requirements for sulfone plastic insert fittings and copper crimp rings for PEX plastic tubing. These fittings are intended for use in 100 psi (690 kPa) cold- and hot-water distribution systems operating at temperatures up to and including 180°F (82°C). Included are requirements for material, molded part properties, performance, workmanship, dimensions, and markings to be used on fittings and rings. Size range is 3/8 to 1 inch.

ASTM F2434: Standard Specification for Metal Insert Fittings Utilizing a Copper Crimp Ring for SDR9 PEX Tubing and SDR9 PEX-AL-PEX Tubing

This specification covers metal insert fittings with o-ring seals and copper crimp rings for use with cross-linked polyethylene (PEX) tubing that meet the requirements for ASTM F876 and F877 and for use with cross-linked polyethylene –aluminium-cross-linked polyethylene (PEX-AL-PEX) tubing that meet the requirements for ASTM F2262. These fittings are intended for use in 100 psi (689.5 kPa) cold- and hot-water distribution systems operating at temperatures up to and including 180°F (82°C). Included are the requirements for materials, workmanship, dimensions, performance, and markings to be used on the fittings and rings. Size range is 1/2 to 1 1/4 inches.

ASSE Standard I06I

Performance Requirements for Push-Fit Fittings

This standard applies to push-fit fittings up to 2” that can be used with one or more of the following materials:

1. PEX tubing complying with ASTM F876 or CSA B137.5;
2. Type K, L and M copper tubing complying with ASTM B88;
3. CPVC tubing complying with ASTM D2846 or CSA B137.6 and
4. PE-RT complying with ASTM F2769.

Push-fit fittings may be designed to be used with one or more types of tubing that conform to the dimensions as specified in their respective standard. This standard serves to supplement ASTM F877, ASTM D2846 and ASTM B88 in describing a test method for a specific type of push-fit fitting system to be used with PEX, Copper, CPVC and/or PE-RT tubing. This standard covers minimum temperature and pressure ratings, marking, and identification.

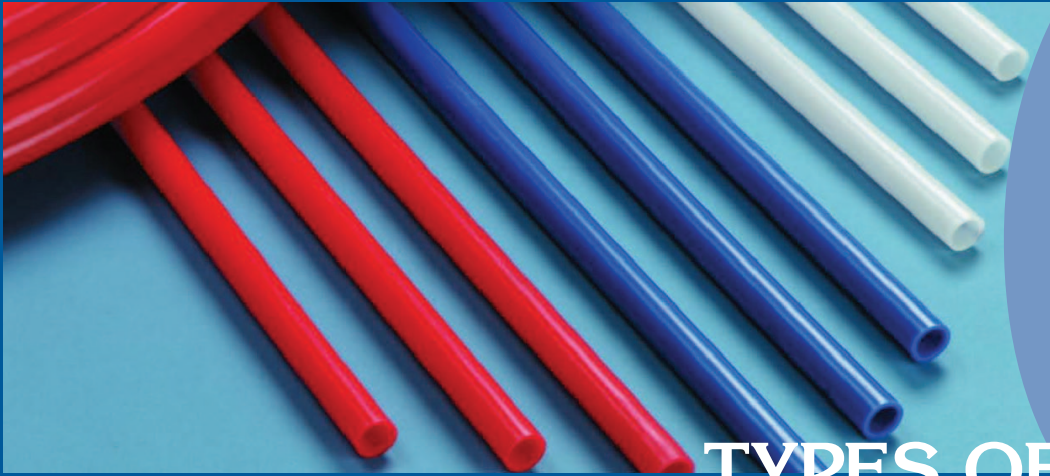

TYPES OF PEX PLUMBING SYSTEMS

The unique properties of PEX piping allow it to be configured in a number of different residential plumbing system designs. This section describes three layout options: trunk and branch, parallel pipe systems (parallel), and zone. By carefully choosing the right system for the application, the plumbing designer can produce a home that balances cost, installation time, environmental soundness, and performance.



Trunk and Branch

For decades, trunk and branch (T&B) piping systems have been used by plumbers for potable water distribution using rigid plastic or metal pipe. Installation of PEX piping can be performed in a similar manner using a main trunk line to supply various branch take-offs to specific outlets. Typically the trunk line services numerous outlets while the branch line services generally one to three closely grouped outlets, such as in a bathroom. Installation of PEX piping in the T&B design follows the general design requirements established in plumbing codes.

As with rigid piping systems, use of tee and elbow fittings allows for the connection of branch take-offs from the main trunk. However, given the fact that PEX is available in long coils, the use of coupling fittings can be reduced or eliminated. Unlike rigid pipe systems, many elbow fittings can be eliminated in favor of sweep turns of the piping.

Specific features and advantages of the PEX trunk and branch design include:

- Simple system design conversion from rigid piping to flexible PEX piping
- Opportunities to reduce the number of fittings installed
- T&B systems will deliver hot water quicker during sequential flows
- T&B systems will generally supply one fixture at a higher pressure

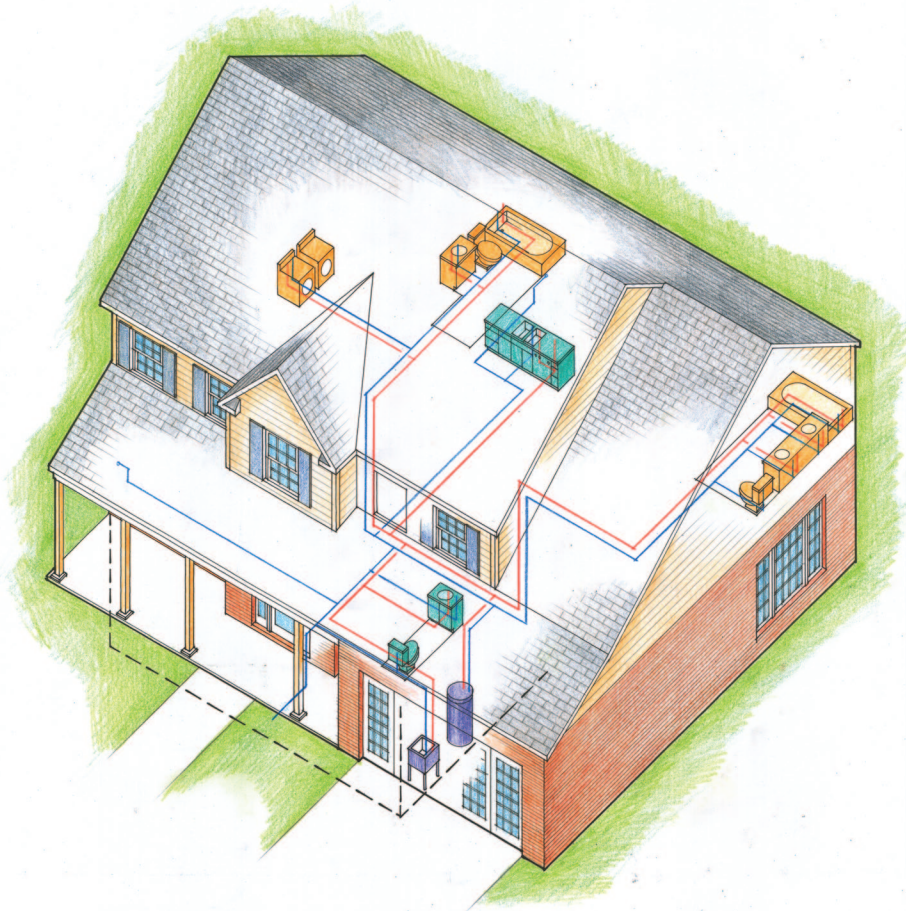

Figure 6.1 – PEX Pipes in a Trunk and Branch System Design

Parallel

The unique features of PEX piping make it ideal for use in manifold-type system designs, commonly referred to as parallel plumbing systems. In this design, all fixtures are fed from dedicated piping that runs directly and unbroken from central manifolds. The hot water manifold should be located in close proximity to the hot water source to ensure fast and efficient delivery.

All outlets are individually fed from a common manifold or two central manifolds (hot and cold). Because inline fittings are eliminated, pressure losses along the line are reduced, allowing the piping size to be reduced for certain fixtures. Three-eighths-inch piping may be used for lower flow applications and 1/2-inch piping is recommended for higher flow applications.

The parallel system often has more evenly distributed pressure losses when flowing water to fixtures since all lines are fed from a common point, rather than adding multiple fixtures into the same pipe section. Smaller diameter pipe also results in quicker delivery of hot water from the water heater, although each line must be purged independently.

If the manifold is installed using valved outlets, many plumbing codes do not require a second valve at the fixture, speeding installation and adding convenience much like an electrical breaker panel.

Specific features and advantages of the PEX parallel design include:

- Easier piping runs to each fixture using smaller diameter piping
- Opportunity to eliminate all fittings between the manifold and the outlet
- Opportunity to have centrally located individual shut-offs housed at the manifold
- Quicker delivery of hot and cold water to the outlets
- A more stable pressure to each fixture when operating simultaneous fixtures

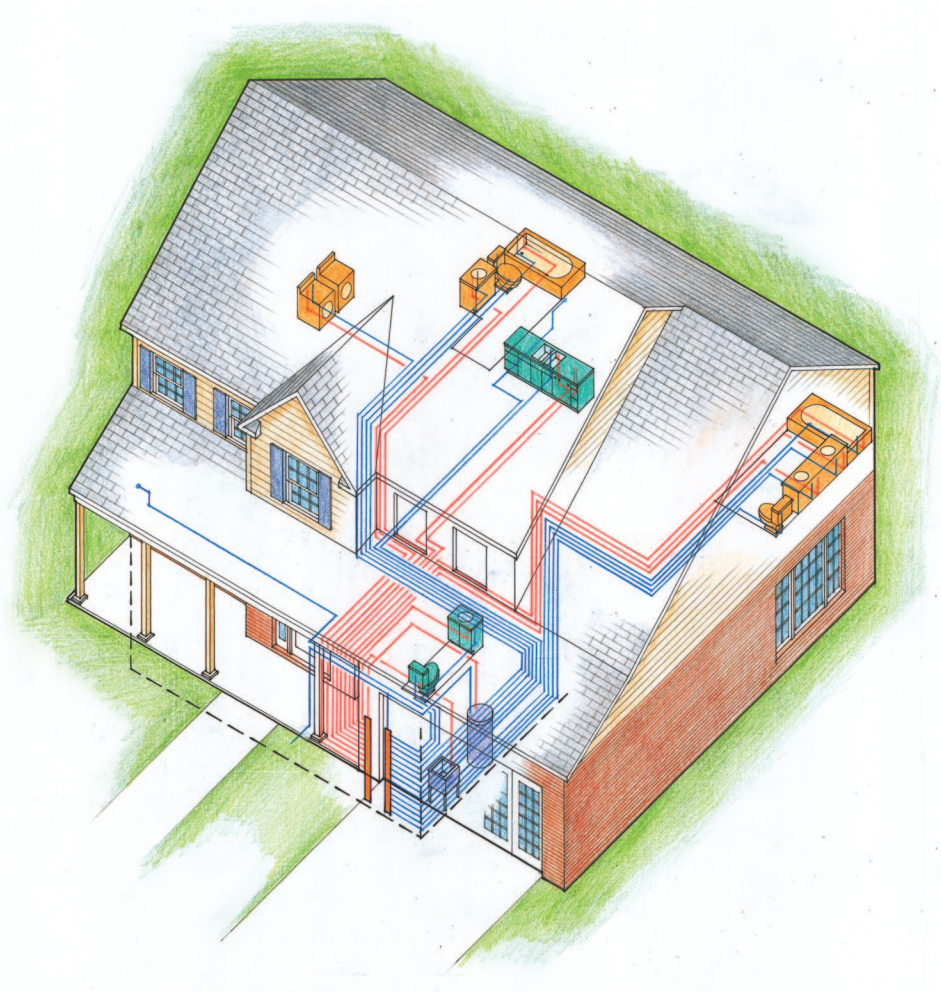

Figure 6.2 – PEX Pipes in a Parallel Design

Zone (Zone and Multi-port Tee)

A third method for installing PEX piping combines elements of the first two systems and is typically referred to as a zone system design. The basic approach to this system is running hot and cold trunk lines to some convenient location in close proximity to multiple fixtures, such as for a bathroom group. At this point a smaller zone or multi-port Tee is installed on each trunk line. The zones or multi-port Tees can be flow-through or closed end. Individual branch lines are then run to each fixture. Manifolds with valves must be installed in accessible locations; manifolds without valves or multi-port Tees may be installed in enclosed spaces.

The zone system performs in a similar manner to the T&B system. However, it simplifies the installation due to the reduced number of fittings that are required.

Specific features and advantages of the PEX zone design include:

- Relatively simple system design conversion from rigid piping to flexible PEX piping
- Opportunities to reduce the number of fittings installed
- Quicker hot water delivery during sequential flows
- Opportunity to have centrally located individual shut-offs at each bathroom group

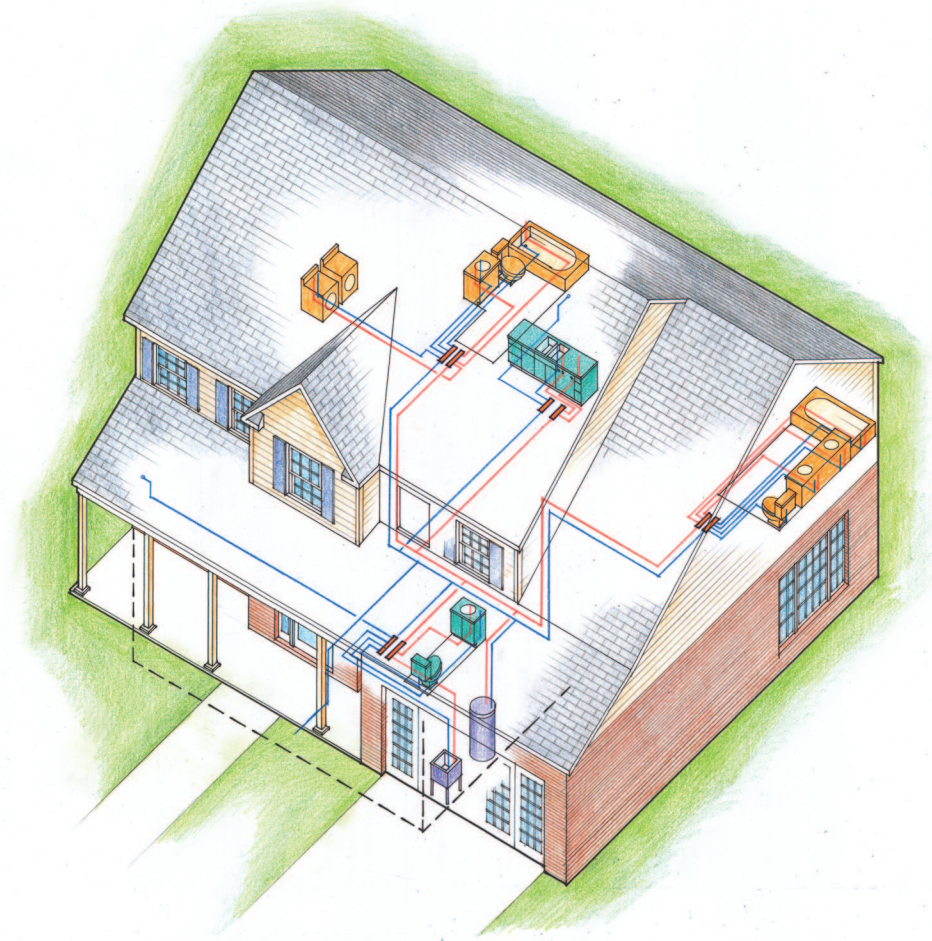

Figure 6.3 – PEX Pipes in a Zone Design



DESIGN

The unique features of PEX piping allow for a great deal of system design freedom that can increase the performance and savings associated with the plumbing system. In today's high-performance homes, many designers recognize that the plumbing system can be designed to provide hot or cold water faster with much less energy loss. PEX plumbing systems can be designed to enhance these features but, like any plumbing system, PEX piping systems perform best and cost less to install when planned during the home's design phase. Advanced planning allows maximum performance, while limiting the lengths of pipe and number of fittings used. And, when considered early enough in the house planning stage, a few simple room layout considerations can greatly improve the performance of the plumbing system. By consulting the codes and local inspectors in advance, builders and plumbers can also avoid costly time delays due to code issues arising during construction.

This chapter describes a process that provides the guidance and tools needed to successfully layout a PEX piping system in nearly any home. Four major areas of the design process are highlighted:

- **Consult Local Codes**
- **Optimize Home Layout**
- **Select Piping System Type**
- **Plan Piping Routing, Manifold, and Valve Locations**

Consult Local Codes

If PEX piping has not been used before, or is still uncommon in your local area, it is helpful to review the local codes for use of PEX piping. As discussed in the Chapter 4 of this document, PEX piping is approved for use in all model codes. Local amendments may restrict or change



the way PEX may be used for certain applications. For that reason, it is important to consult local codes to determine specific requirements before beginning a new piping design.

It may also be helpful to consult with local building inspectors to notify them in advance that you plan to use PEX piping for your project. They can be helpful in pointing out local requirements and amendments. Alerting the inspector of your intent to use a new technology in advance can help to avoid delays that often occur when an unfamiliar material is encountered on the jobsite. This design manual may be useful as a reference guide for an inspector who is unfamiliar with PEX.

In the event that questions arise regarding the application, performance, or code acceptance of PEX, both the Plastics Pipe Institute (PPI) and the Plastic Pipe and Fittings Association (PPFA) can provide support. Each organization can provide technical and training materials to aid code officials and plumbers.

Optimize Home Designs

Ironically, some of the most substantial problems with modern plumbing system designs, relate not to the piping itself, but to the design and layout of the house. The materials that are chosen for framing, the location of rooms, the location of the water heater(s), and the point at which the water main enters the home all have a substantial impact on the performance of a plumbing system. Often, the design of the plumbing system is left until the end of the design process when the home layout is largely determined. This can result in a poorly performing and excessively costly system. By observing a number of guidelines early in the home design process, PEX piping can be installed in a way that minimizes costs, eases installation, and increases homeowner satisfaction.

The key to optimizing home designs for PEX plumbing is to minimize pipe lengths from the water main and water heater. While this may seem intuitive, it cannot be stressed enough. Short piping runs result in shorter wait times for hot water, fewer fittings, faster installation time, and lower material costs. This can be accomplished by the builder or designer in the early planning stage using several basic design principles.

- 1. Group fixtures together** – Grouping plumbing fixtures around a common location can result in saving time, materials, hot water energy, and water. This can be done between floors as well, such as in the case of stacked bathrooms. Where possible, avoid locating bathrooms long distances from the water heater.
- 2. Centrally locate distribution point** – Centrally located water heaters and incoming water supplies can significantly improve the performance of a plumbing system. Often water heaters are arbitrarily located for convenience or placed in the utility room as far from the living space as possible. This approach often leads to exceedingly long plumbing runs along with the resultant increase in materials, installation time, and water and energy use. Whenever feasible, locate the water main and heater as close as possible to the mid-point of the fixture groupings to keep piping runs short.
- 3. Create spaces for bundled pipe runs** – Particularly applicable to parallel-piping PEX plumbing runs where few fittings are installed, simultaneous installation of multiple piping runs will reduce installation time. The flexibility of PEX piping and the long, unbroken lengths that can be easily spooled enable the simultaneous installation of multiple plumbing lines

running in the same direction using common holes and chases. By creating space in soffits and chases for piping bundles, installation time can be reduced. However, cold and hot water lines should be bundled separately.

- 4. Use building elements that ease piping installation** – Using building elements such as open web floor trusses in some locations can dramatically speed up the process of installing plumbing piping. This can also speed up the process of installation of other mechanicals including ducting and wiring.

Select Piping System Design

The next step for the designer, plumber, and builder is to select the most appropriate plumbing system design for the home. The unique properties of PEX piping allow it to be configured in a number of different designs. All have been shown to work well in residential applications, and all are code approved. Depending on the design of the home, each has different performance characteristics, installation costs, material costs, and ease of installation. The selection of a system design is generally based on a combination of key factors such as material cost, labor time, ease of installation, system performance, and installer preference.

The challenge for a plumbing designer is to select the system that balances the unique needs of the installer, homeowner, and builder. The purpose of this chapter is to provide a comparison of the three most prevalent PEX plumbing systems, trunk and branch, parallel, and zone, and the guidance to select between system types.

Selecting among the three systems described is not cut and dry, and often involves a balance of the key factors since each project, installer, and circumstance is different. Fortunately, there is no wrong choice. All three system designs will supply sufficient flow and pressure to the outlets even when the base riser pressure is 40 psi and the length to the farthest outlet is 100 feet. But, the costs and performance of each system do vary for each house design. Selecting the best system for your project can reduce installation costs, minimize installation headaches, and lead to more satisfied homeowners.

To aid in the decision-making process, several tools are provided.

- 1. General Rankings of the Systems for Key Factors** – This general comparison will provide a place to start and compare how the systems stack up based on your priorities.
- 2. Example Layouts** – Detailed layouts of each system are provided for four common house types. By selecting the type that most closely resembles your project, you can see how the systems compare for your building design.
- 3. Performance Testing** – The three systems were compared and tested in comprehensive laboratory tests. By examining the test data you can identify differences in the systems' performance in varying scenarios.
- 4. Industry Technical Support** – Manufacturers and organizations offer a range of resources to assist PEX users. The support ranges from general information to technical assistance on specific projects.

General Rankings of the Systems for Key Factors

The general characteristics of the systems are ranked in Table 7.1. Given the wide difference between housing designs and preferences, they may not apply in every situation, but are useful for general guidance as you design your home. The best way to use the table below is to establish the relative priority of key factors, and use the rankings of system designs to provide a starting point for the system to be selected.

For example, if when considering the factors in the table below, you determine that your top three factors are:

1. Minimizing Fittings and Joints⁵
2. Centralized Shut-off Valving
3. Pressure Stability with Use of Multiple Fixtures

Then, given the fact that the parallel system ranks at the top of all three, it is a logical place to start. However, if your top factors give you three different best designs, the right choice is not as obvious. You will then need to consider other factors, and further explore the detailed design of your home to make a choice. The example layouts later in this chapter may then be helpful in making a choice.

Table 7.1 – General Rankings of the System Characteristics			
Factor	***	**	*
Minimize Pipe Used	Trunk and Branch	Zone	Parallel
Minimize Fittings and Joints	Parallel	Zone	Trunk and Branch
Sequential Flow Hot Water Delivery Time	Trunk and Branch Zone		Parallel
Minimize Hot Water Wait Time	Parallel	Zone	Trunk and Branch
Single Fixture Pressure	Trunk and Branch	Parallel Zone	
Pressure Stability with Use of Multiple Fixtures	Parallel	Zone	Trunk and Branch
Centralize Shut-off Valving	Parallel	Zone	Trunk and Branch
Joint Accessibility During Installation	Parallel	Zone	Trunk and Branch
*** Indicates the highest level of performance for that factor * Indicates typical performance			

⁵A fitting is the device that allows the PEX pipe to change direction or size (i.e., tees, elbows, reducers). A joint is the connection of the PEX pipe to a fitting (i.e., a tee fitting has three joints).

Cost has been omitted as a factor in this guide. Since local labor costs vary, and there is variation between the fitting and piping costs offered by different manufacturers, this guide simply provides information on the amount of pipe and fittings needed. Since the balance between material and labor cost varies across the country, the determination of actual cost estimates and total cost comparison between system designs is left to the designer or installer.

Example Layouts

The following plumbing system layouts provide supply water diagrams and estimated fittings and piping descriptions for the four most common house types: Colonial, Ranch, Townhouse, and Condominium. Each house type has three piping layouts that illustrate each of the three system designs. Piping lengths, and fitting and joint counts are provided for each system to provide a comparison of material use and labor required. You can select the home design that most closely resembles your home design to help select the system that is right for you. Note that in these designs, few obstructions are accounted for and thus represent idealized pipe runs with a minimum of fittings.

Table 7.2 outlines the number and type of fixtures for each house.

Fixture	Colonial	Ranch	Townhouse	Condominium
Kitchen Sink	1	1	1	1
Dishwasher	1	1	1	1
Lavatory	4	3	2	3
Water Closet	3	2	2	2
Shower/Tub	3	3	1	3
Clothes Washer	1	1	1	1
Utility Sink	1	0	0	0
Hose Bibbs	2	2	2	0
Total	16	13	10	11

Colonial Layout

The Colonial house layout has approximately 2,000 square feet of floor area. The water main enters the house under the unfinished basement slab. The water heater is located near the main water line in the basement. The first floor has a living room, dining room, kitchen, family room, and a powder room. The second floor has four bedrooms, two full baths, and the clothes washer.

Level	Kitchen Sink	Dishwasher	Lavatory	Water Closet	Shower/Tub	Clothes Washer	Utility Sink	Hose Bibb	Total
Basement	0	0	0	0	0	0	1	0	1
First Floor	1	1	1	1	0	0	0	2	6
Second Floor	0	0	3	2	3	1	0	0	9
Total	1	1	4	3	3	1	1	2	16

System	Length of Cold Pipe			Length of Hot Pipe			Fittings		Manifolds/ Multi-port Tees		Joints	
	1"	3/4"	1/2"	1"	3/4"	1/2"	Tees	Elbows	Main	Remote	Fixtures	Piping
Trunk and Branch	27'	80'	110'	0'	80'	98'	25	10	0	0	26	97
Parallel	33'	12'	602'	0'	12'	428'	2	7	2	0	26	49
Zone	27'	93'	152'	0'	93'	107'	8	13	0	7	26	83

In larger homes with a large separation between bathrooms, the trunk and branch design uses the least amount of total pipe but the most fittings and joints. The parallel system uses the most piping (2.4 times on average) and the least amount of fittings and joints. While the parallel system uses more piping, the piping has a smaller diameter which is easier to handle and install, particularly around bends. An appropriate balance between labor and material costs as well as the relative performance of the systems is important when deciding on a system layout for your particular house.

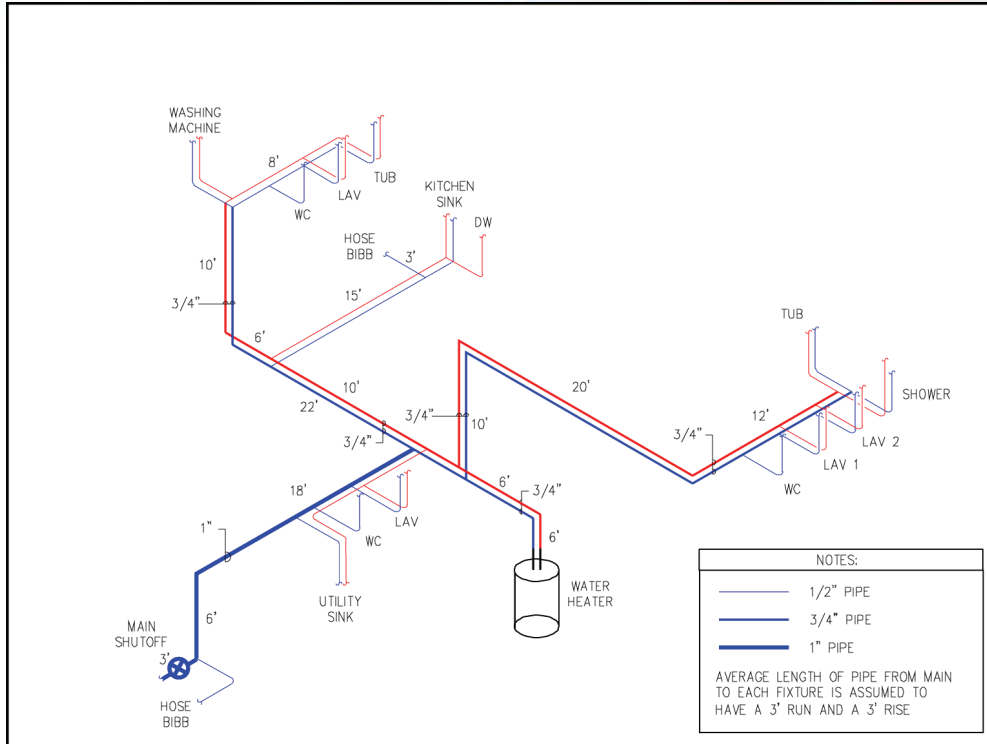

Figure 7.1 – Trunk and Branch Isometric Riser for the Colonial House

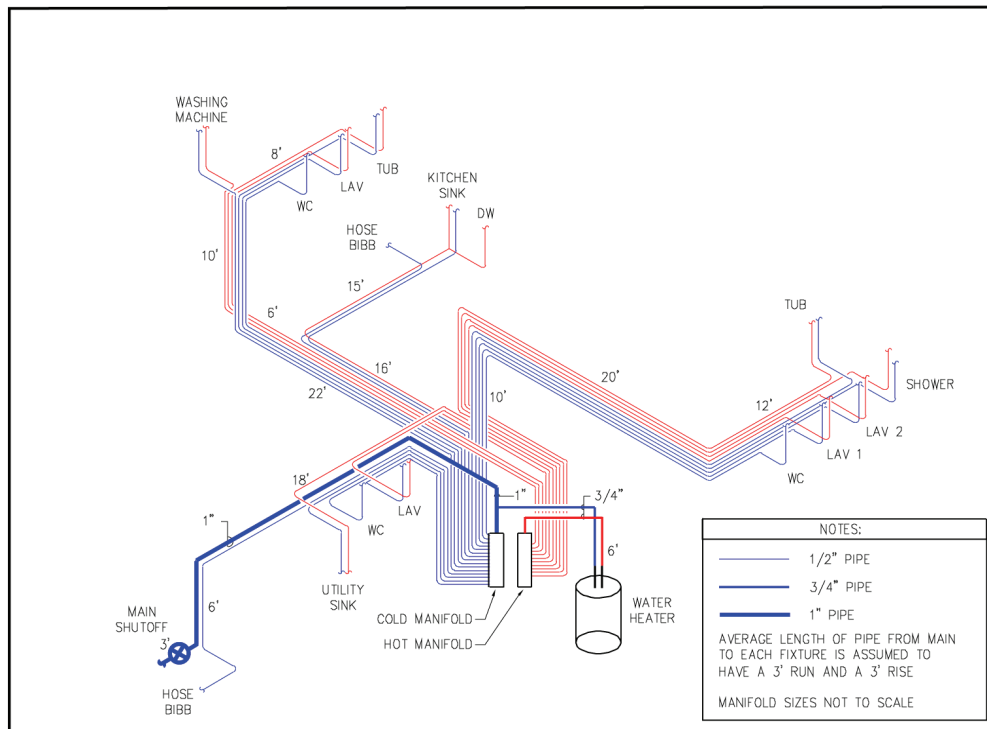

Figure 7.2 – Parallel Isometric Riser for the Colonial House

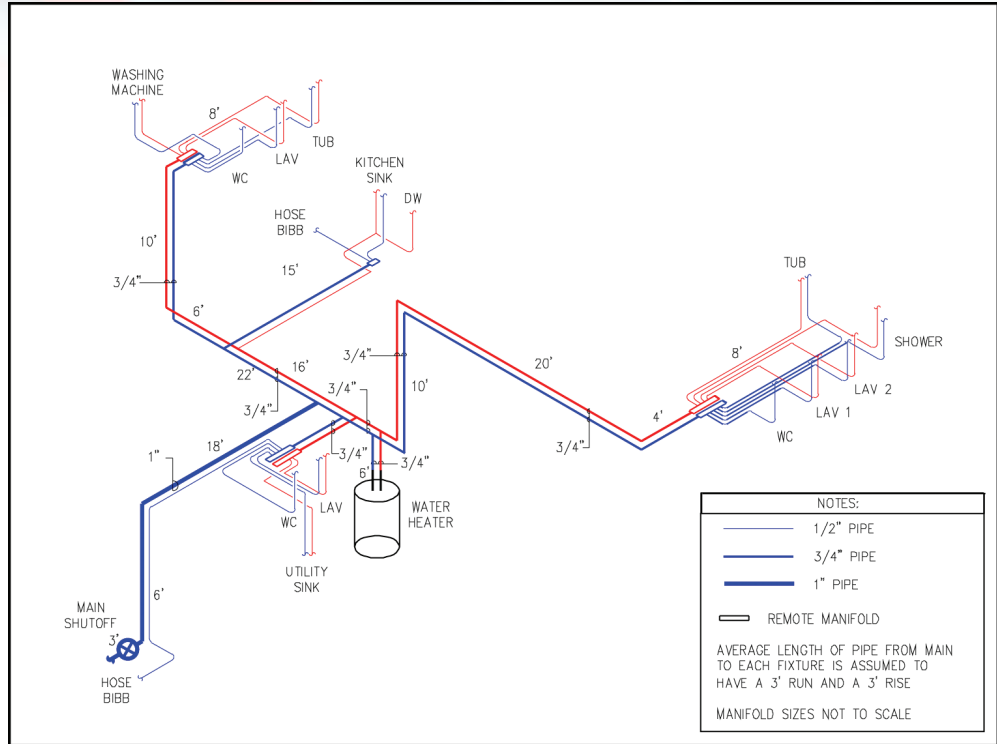

Figure 7.3 – Zone Isometric Riser for the Colonial House

Ranch Layout

The Ranch house has approximately 1,300 square feet of one-story floor area. The water main enters the house under the slab on grade. The one-story floor plan includes a great room, a kitchen, a dining room, three bedrooms, and two full baths. The water heater and clothes washer are located in the utility room.

Table 7.5 – Fixture Summary for the Ranch House

Level	Kitchen Sink	Dishwasher	Lavatory	Water Closet	Shower/Tub	Clothes Washer	Utility Sink	Hose Bibb	Total
Main Floor	1	1	3	2	3	1	0	2	13

Table 7.6 – Material Summary for the Ranch House

System	Length of Cold Pipe			Length of Hot Pipe			Fittings		Manifolds/ Multi-port Tees		Joints	
	1"	3/4"	1/2"	1"	3/4"	1/2"	Tees	Elbows	Main	Remote	Fixtures	Piping
Trunk and Branch	25'	75'	112'	0'	72'	81'	20	5	0	0	21	71
Parallel	25'	10'	413'	0'	10'	294'	2	5	2	0	21	39
Zone	25'	59'	196'	0'	59'	159'	8	4	0	4	21	53

In home layouts with a large separation between fixtures, the trunk and branch design uses the least amount of pipe followed by the zone design. The parallel system uses the most piping (1.8 times more on average) and the least amount of fittings and joints. The parallel system uses more piping, but with smaller diameters, which is easier to handle and install, particularly around bends. An appropriate balance between labor and material costs as well as the relative performance of the systems is important when deciding on a system layout for your particular house.

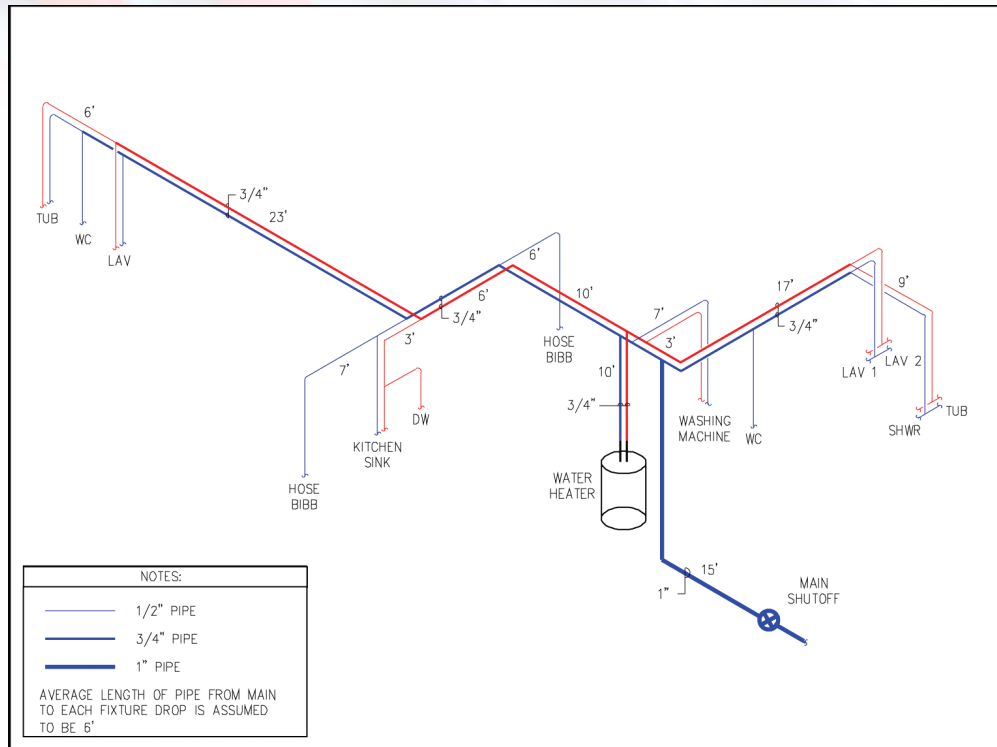

Figure 7.4 – Trunk and Branch Isometric Riser for the Ranch House

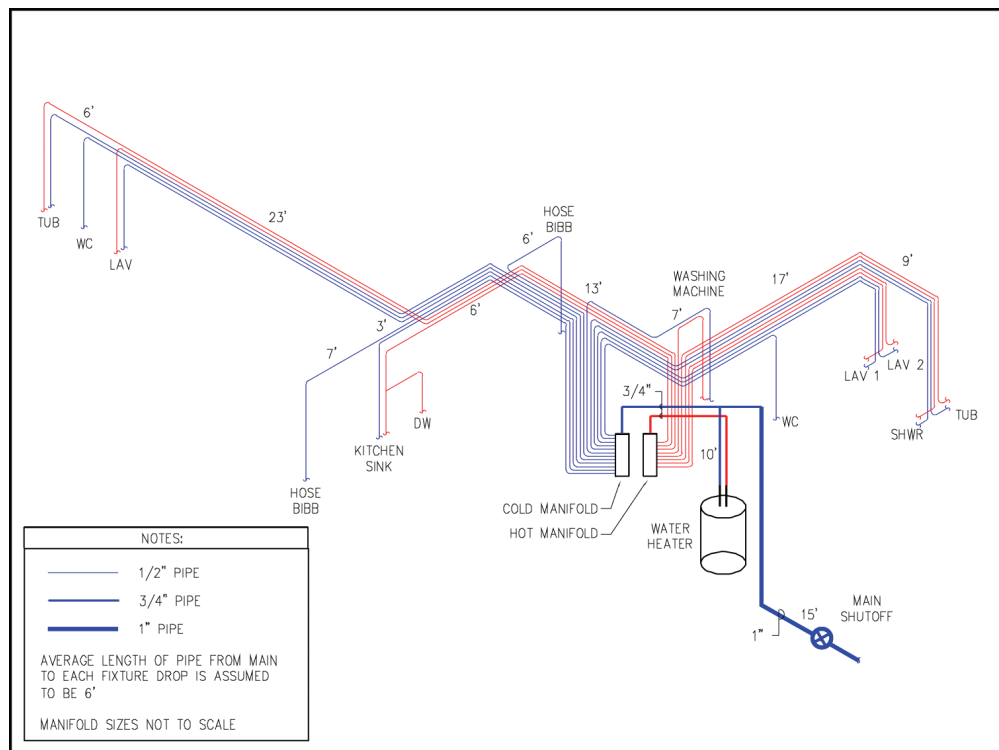

Figure 7.5 – Parallel Isometric Riser for the Ranch House

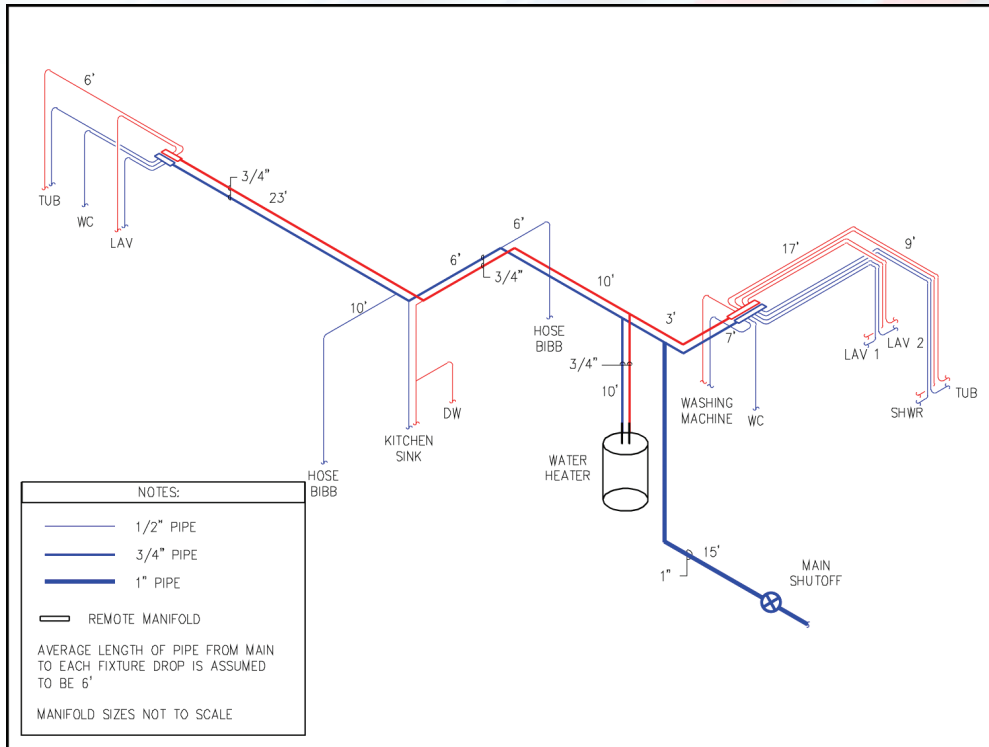

Figure 7.6 – Zone Isometric Riser for the Ranch House

Townhouse Layout

The Townhouse has two stories and is approximately 1,000 square feet of floor area. The water main enters the house under the first floor’s slab on grade. The first floor has a living room, kitchen, dining room, and a powder room. The second floor has two bedrooms and one full bath. The water heater and clothes washer are located on the first floor.

Table 7.7 – Fixture Summary for the Townhouse

Level	Kitchen Sink	Dishwasher	Lavatory	Water Closet	Shower/Tub	Clothes Washer	Utility Sink	Hose Bibb	Total
First Floor	1	1	1	1	0	1	0	2	7
Second Floor	0	0	1	1	1	0	0	0	3
Total	1	1	2	2	1	1	0	2	10

Table 7.8 – Material Summary for the Townhouse

System	Length of Cold Pipe			Length of Hot Pipe			Fittings		Manifolds/ Multi-port Tees		Joints	
	1"	3/4"	1/2"	1"	3/4"	1/2"	Tees	Elbows	Main	Remote	Fixtures	Piping
Trunk and Branch	0'	66'	86'	0'	30'	44'	14	8	0	0	15	59
Parallel	0'	42'	247'	0'	11'	138'	2	8	2	0	15	39
Zone	0'	67'	100'	0'	30'	44'	5	7	0	2	15	42

In this more compact house design, the differences between the trunk and branch and zone systems are primarily in reduced fittings and joints for the zone system. The parallel system uses considerably more pipe (1.9 times more on average) as the trunk and branch and zone designs. The parallel system uses more piping with smaller diameters, which is easier to handle and install, particularly around bends. An appropriate balance between labor and material costs as well as the relative performance of the systems is important when deciding on a system layout for your particular house.

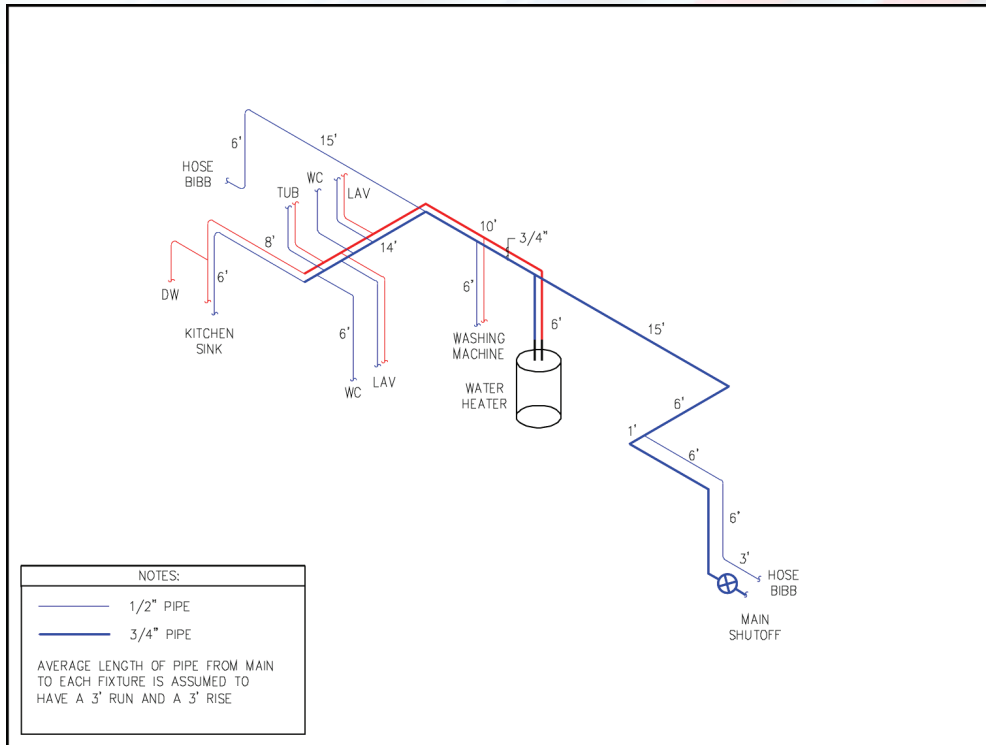

Figure 7.7 – Trunk and Branch Isometric Riser for the Townhouse

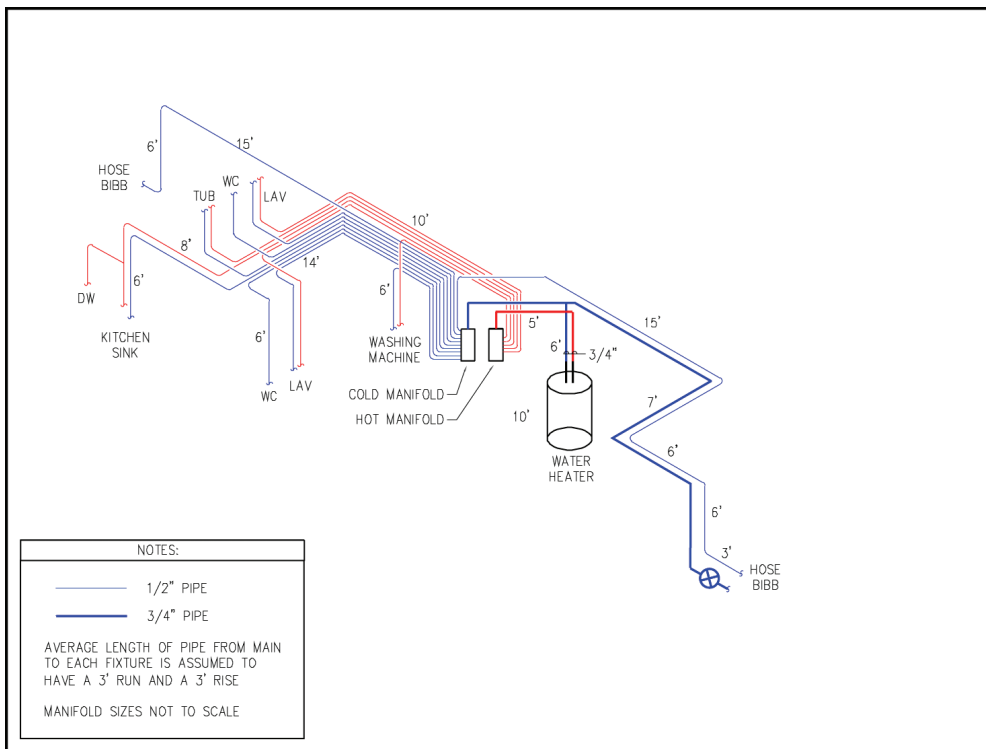

Figure 7.8 – Parallel Isometric Riser for the Townhouse

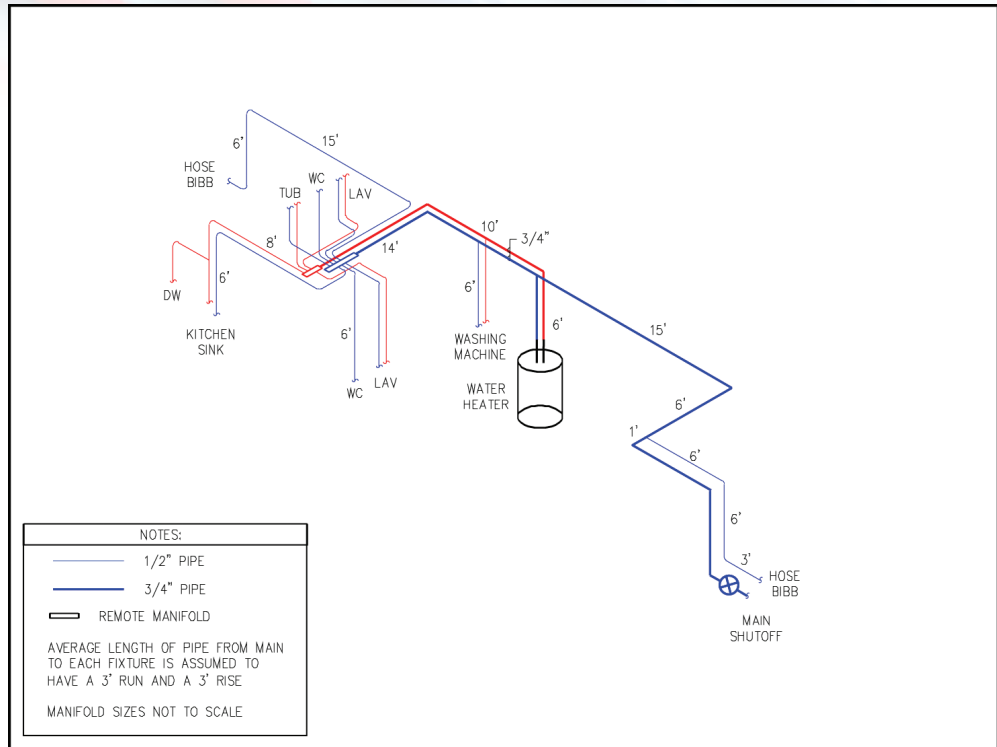

Figure 7.9 – Zone Isometric Riser for the Townhouse

Condominium Layout

The Condominium has approximately 1,200 square feet of floor area. It has a living room, kitchen, dining room, two bedrooms, and two full baths. The clothes washer is located in the unit. The condominium building has a central plant for water heating; therefore, there is no water heater located in the unit.

Table 7.9 – Fixture Summary for the Condominium

Level	Kitchen Sink	Dishwasher	Lavatory	Water Closet	Shower/Tub	Clothes Washer	Utility Sink	Hose Bibb	Total
Main Floor	1	1	3	2	3	1	0	0	11

Table 7.10 – Material Summary for the Condominium

System	Length of Cold Pipe			Length of Hot Pipe			Fittings		Manifolds/ Multi-port Tees		Joints	
	1"	3/4"	1/2"	1"	3/4"	1/2"	Tees	Elbows	Main	Remote	Fixtures	Piping
Trunk and Branch	0'	45'	120'	0'	45'	104'	17	0	0	0	19	53
Parallel	0'	10'	295'	0'	10'	242'	1	2	2	0	19	29
Zone	0'	35'	132'	0'	35'	115'	5	0	0	4	19	37

The trunk and branch system uses the most tees which increases the number of joints. The trunk and branch and zone system layouts are similar in pipe use, but the zone system uses fewer fittings resulting in fewer joints. The parallel system uses the most pipe (1.8 times more on average) and the least amount of fittings. The parallel system uses more pipe with smaller diameters, which is easier to handle and install, particularly around bends. An appropriate balance between labor and material costs as well as the relative performance of the systems is important when deciding on a system layout for your particular house.

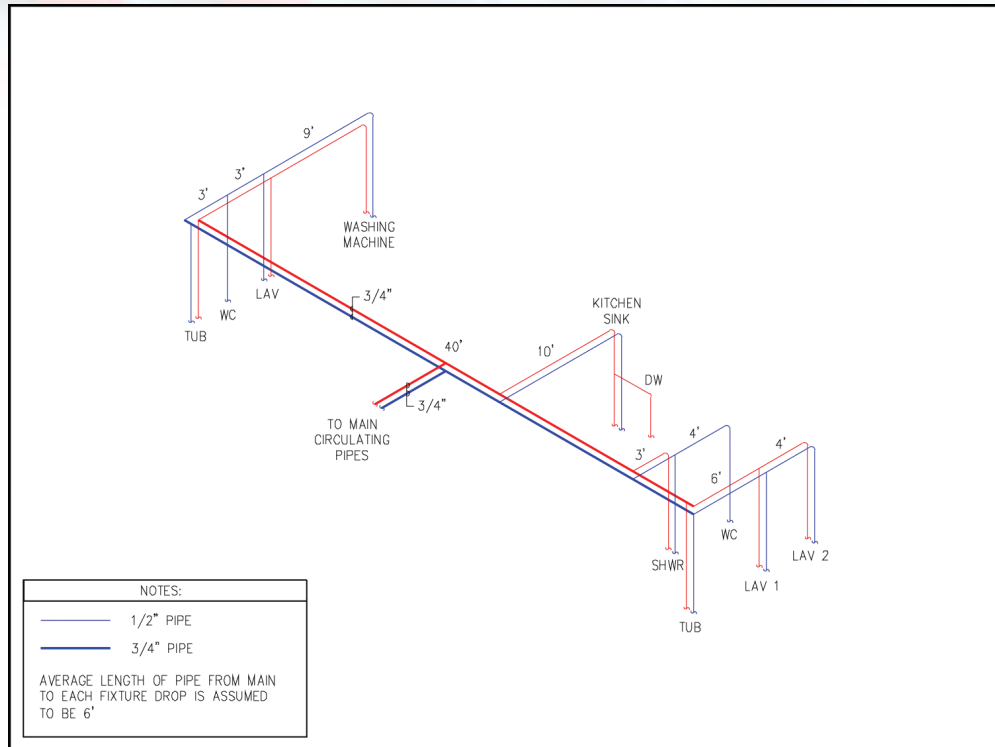

Figure 7.10 – Trunk and Branch Isometric Riser for the Condominium

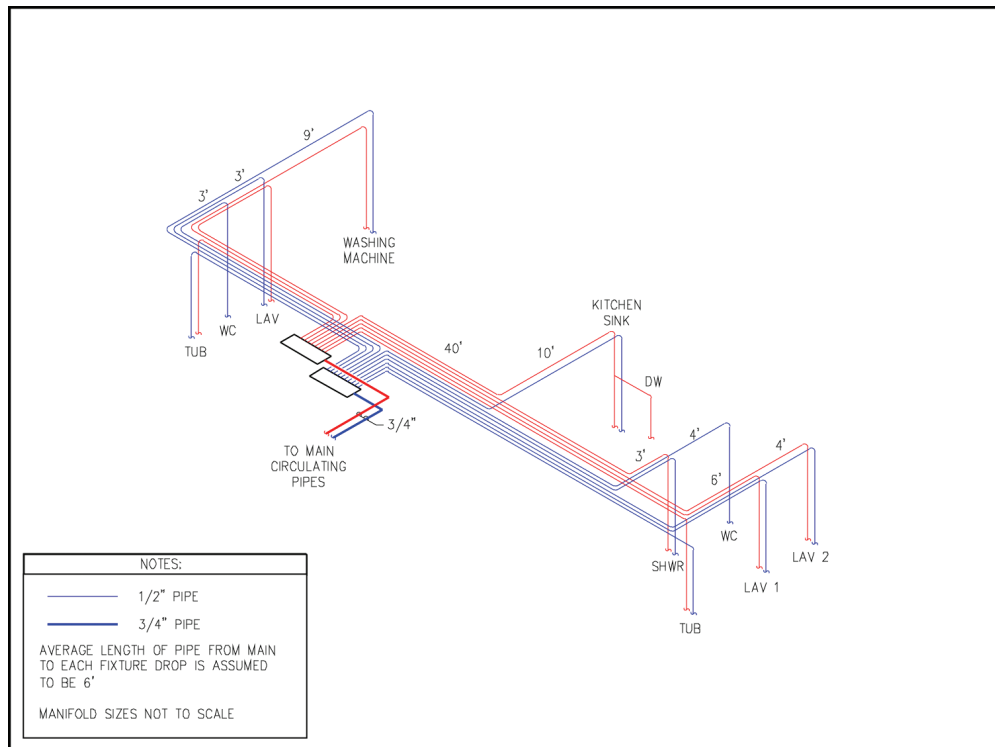

Figure 7.11 – Parallel Isometric Riser for the Condominium

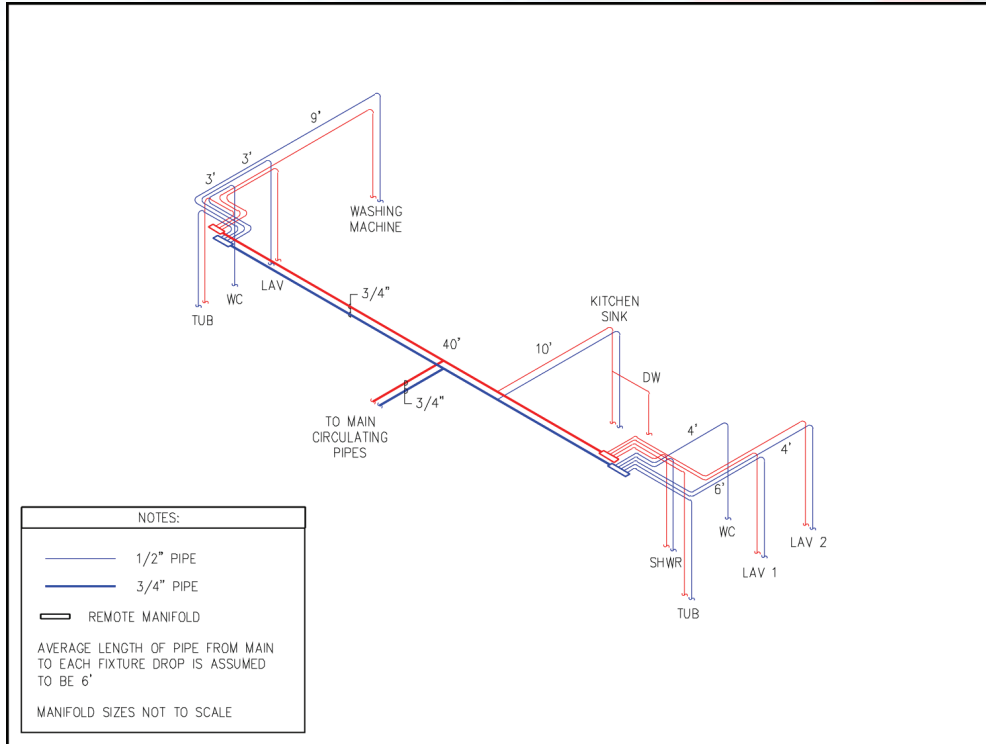

Figure 7.12 – Zone Isometric Riser for the Condominium

Table 7.11 – PEX Pipe Dimensions					
Nominal Diameter	OD	Wall	ID	Weight	Volume ³
	inches ¹	inches ²	inches	lb/ft	gallon/100ft
3/8"	0.500	0.075	0.350	0.04	0.5
1/2"	0.625	0.075	0.475	0.05	1.0
5/8	0.750	0.083	0.574	0.07	1.3
3/4"	0.875	0.102	0.671	0.10	1.9
1"	1.125	0.132	0.862	0.17	3.2
1 1/4"	1.375	0.161	1.054	0.25	4.7
1 1/2"	1.625	0.191	1.244	0.35	6.5
2"	2.125	0.248	1.629	0.60	11.1

¹ Average OD from ASTM F 876
² Average wall thickness from ASTM F 876
³ Typical pipe volumes in US gallons, not imperial

Performance Verification Laboratory Testing

A set of laboratory tests using typical plumbing fixtures and plumbing pipe sizes, runs and fittings was performed to demonstrate the flow characteristics of the three different PEX systems. Results of this testing indicate that all three systems will supply adequate pressure and water delivery to a remote shower fixture located 100 feet from the base riser with an elevation head of 15 feet. Base source pressures of 40, 60, and 80 psi were used in each of the different system designs. Multiple tests were performed to add simultaneous flows from other fixtures including a shower, lavatory, kitchen and water closet. Test results are shown in Chapter 8.

Industry Technical Support

If you have questions that have not been answered in this Design Guide, you can contact the PEX manufacturer directly. The following websites provide a wealth of general information on PEX piping.

Plastics Pipe Institute
www.plasticpipe.org

Plastic Pipe and Fittings Association
www.ppfahome.org

Home Innovation Labs
www.HomeInnovation.com

Manufacturers of PEX piping and fittings can also provide specific technical assistance during the design, planning, and installation phases. Contact information for each can be found at the PPI and PPFA websites and on the individual manufacturers' sites.

Plan Pipe Routing, Manifold/Multi-port Tee, and Valve Locations

Once the system design is selected, the final step in the design process is to plan pipe routing, manifold/multi-port tee, and valve locations. As in the case of the home design optimization, there are several guidelines that can simplify this process. Bear in mind that PEX piping is available in continuous coils as well as 20-foot straight lengths. Consult the local codes for specific installation requirements for your project.

Guidelines for optimizing the design of a PEX plumbing system include:

- 1. Minimize fittings** – The flexibility of PEX piping enables it to be easily installed around obstructions and through framing members. Use of sweep turns (i.e., bending the pipe in a gentle sweep rather than using solid fittings) to change direction can result in quicker installations, fewer mechanical fittings, and less resistance due to pressure drops common through fittings.
- 2. Group fixtures together** – If using trunk and branch or zone, use common trunk lines to feed multiple fixture groups. For example, if two bathrooms are stacked, use a single zone/multi-port tee to feed both, rather than two zones/multi-port tee.
- 3. Minimize pipe lengths** – Though this may seem intuitive, attention to this detail should lead to efficiently installed plumbing systems, especially when considering plumbing layouts using PEX piping.

- 4. Select appropriate pipe diameter** – Many plumbing systems are installed using standard practices that apply to very large homes but are excessive for smaller homes. Taking a short amount of time to plan the piping sizes needed to supply the proper flow rates at the required pressure, will result in the use of pipe sizes that deliver the required fixture flow rate, but are not oversized. Oversized plumbing system designs result in wasted energy and water, as well as reduce customer satisfaction with the plumbing system.
- 5. Bundle pipe runs** – Applicable particularly to PEX plumbing runs where few fittings are installed, installation of multiple piping runs at the same time will reduce installation time. The flexibility of PEX piping and the long unbroken lengths that can be easily spooled to enable the simultaneous installation of multiple plumbing lines running in the same direction using common holes through barriers such as joists.
- 6. Plan for solid attachment of transition points** – The flexibility of PEX piping also requires that the transition to threaded fittings or rigid piping be performed correctly. As with most piping materials, solid connection points and solid attachment points are necessary when threading on valves and transition fittings to other materials.
- 7. Use color coding** – PEX is available in different colors. Using dedicated colors for hot, cold, and greywater, where applicable, can be helpful for installers, homeowners, and future retrofits.

Before locating manifolds, determine whether valves will be placed at fixtures or on manifolds. Some jurisdictions require valves at the fixture, while others allow them to be located on central manifolds. In some cases the homeowner may express a preference for the location of shut-off valves. If valves are to be placed on manifolds, they must be situated to allow easy access. This can be accomplished by placing them behind access panels, or open in basements, laundry rooms, mechanical rooms, or garages where no freeze potential exists. It is also important to label each valve on the manifold to ensure easy identification of the distribution lines. If valves are not placed on the manifolds, and local codes allow, the manifolds may be enclosed within walls or floors, similar to any other fitting such as a tee or ell.

Table 7.12 – Flow Velocity

Flow Rate GPM	Flow Velocity ft/sec							
	3/8"	1/2"	5/8"	3/4"	1"	1 1/4"	1 1/2"	2"
0.5	1.67	0.91	0.62	0.45	0.27	0.18	0.13	0.08
0.75	2.50	1.36	0.93	0.68	0.41	0.28	0.20	0.12
1.0	3.33	1.81	1.24	0.91	0.55	0.37	0.26	0.15
1.5	5.00	2.72	1.86	1.36	0.82	0.55	0.40	0.23
2.0	6.67	3.62	2.48	1.81	1.10	0.74	0.53	0.31
2.5	8.34	4.53	3.10	2.27	1.37	0.92	0.66	0.38
3.0	10.00	5.43	3.72	2.72	1.65	1.10	0.79	0.46
3.5	11.67	6.34	4.34	3.18	1.92	1.29	0.92	0.54
4.0		7.24	4.96	3.63	2.20	1.47	1.06	0.62
4.5		8.15	5.58	4.08	2.47	1.65	1.19	0.69
5.0		9.05	6.20	4.54	2.75	1.84	1.32	0.77
6.0		10.86	7.44	5.44	3.30	2.21	1.58	0.92
7.0			8.68	6.35	3.85	2.57	1.85	1.08
8.0			9.92	7.26	4.40	2.94	2.11	1.23
9.0			11.16	8.17	4.95	3.31	2.38	1.39
10.0				9.07	5.50	3.68	2.64	1.54
11.0				9.98	6.05	4.04	2.90	1.69
12.0				10.89	6.60	4.41	3.17	1.85
13.0				11.79	7.15	4.78	3.43	2.00
14.0					7.70	5.15	3.70	2.16
15.0					8.25	5.52	3.96	2.31
16.0					8.80	5.88	4.22	2.46
17.0					9.35	6.25	4.49	2.62
18.0					9.90	6.62	4.75	2.77
19.0					10.45	6.99	5.02	2.92
20.0					11.00	7.35	5.28	3.08
25.0						9.19	6.60	3.85
30.0						11.03	7.92	4.62
35.0							9.24	5.39

Table 7.12 – Flow Velocity *(continued)*

Flow Rate	Flow Velocity ft/sec							
GPM	3/8"	1/2"	5/8"	3/4"	1"	1 1/4"	1 1/2"	2"
40.0							10.65	6.16
45.0							11.88	6.93
50.0								7.70
55.0								8.47
60.0								9.24
65.0								10.01
70.0								10.78
75.0								11.55

Table 7.13 – Pressure Loss

60°F (16°C) Water

Flow Rate	Pressure Loss psi/100 ft of Pipe							
GPM	3/8"	1/2"	5/8"	3/4"	1"	1 1/4"	1 1/2"	2"
0.5	1.95	0.44	0.18	0.08	0.02	0.01	0.00	0.00
0.75	4.14	0.94	0.37	0.17	0.05	0.02	0.01	0.00
1.0	7.05	1.59	0.63	0.30	0.09	0.03	0.01	0.00
1.5	14.93	3.38	1.35	0.63	0.19	0.07	0.03	0.01
2.0	25.44	5.76	2.29	1.07	0.32	0.12	0.05	0.01
2.5	38.45	8.70	3.46	1.62	0.48	0.18	0.08	0.02
3.0	53.90	12.20	4.86	2.27	0.67	0.25	0.11	0.03
3.5	71.70	16.23	6.46	3.02	0.89	0.34	0.15	0.04
4.0		20.78	8.27	3.87	1.14	0.43	0.19	0.05
4.5		25.85	10.29	4.81	1.42	0.53	0.24	0.06
5.0		31.41	12.51	5.85	1.73	0.65	0.29	0.08
6.0		44.03	17.53	8.20	2.42	0.91	0.41	0.11
7.0			23.32	10.91	3.22	1.21	0.54	0.15
8.0			29.86	13.97	4.13	1.55	0.69	0.19
9.0			37.14	17.38	5.14	1.93	0.86	0.23
10.0				21.12	6.24	2.35	1.05	0.28

Table 7.13 – Pressure Loss <i>(continued)</i>								
60°F (16°C) Water								
Flow Rate	Pressure Loss psi/100 ft of Pipe							
GPM	3/8"	1/2"	5/8"	3/4"	1"	1 1/4"	1 1/2"	2"
11.0				25.20	7.45	2.80	1.25	0.34
12.0				29.60	8.75	3.29	1.47	0.40
13.0				34.33	10.15	3.81	1.70	0.46
14.0					11.64	4.38	1.95	0.53
15.0					13.23	4.97	2.22	0.60
16.0					14.91	5.60	2.50	0.67
17.0					16.68	6.27	2.80	0.75
18.0					18.54	6.97	3.11	0.84
19.0					20.49	7.70	3.44	0.93
20.0					22.54	8.47	3.78	1.02
25.0						12.81	5.72	1.54
30.0						17.95	8.01	2.16
35.0							10.66	2.87
40.0							13.65	3.68
45.0							13.98	4.57
50.0								4.56
55.0								6.63
60.0								7.79
65.0								9.04
70.0								10.37
75.0								11.78

Shown is pressure loss in units of psi per 100 feet of pipe.



PERFORMANCE DATA

Following the introduction of PEX plumbing systems in North America in the 1980's and the rapid growth of its usage in the 1990's, a significant amount of research on the performance of PEX plumbing systems has been conducted since 2000, with the objectives of determining the most efficient and effective plumbing designs for residential and light commercial applications.

For the reference of plumbing designers, installers, builders, plumbing engineers and inspectors, this chapter is intended to present and summarize the recent research, which demonstrates the high levels of performance from various PEX plumbing designs.

This chapter includes laboratory performance data on three common PEX plumbing design techniques – trunk-and-branch, parallel, zone (remote manifold) – and provides both objective and subjective ratings of each of these designs for various type of residences while considering numerous criteria.

Also included are studies to evaluate the ability of PEX plumbing systems to absorb pressure surges in residential plumbing systems, and to measure empirical performance data with fixture flow comparisons of PEX versus copper plumbing systems. The results of each study are summarized on page 74 and 75, respectively.

System Performance Comparison

Each of the three PEX plumbing configurations described in this guide can be installed in most homes with satisfactory performance. The different systems offer opportunities to optimize the performance of the plumbing system, reduce the installed cost, and increase overall customer satisfaction and acceptance. In order to quantify the differences between PEX system designs, each system was tested in the laboratory to provide a similar set of conditions under which the systems are installed and operated. Actual residential plumbing fixtures, piping layouts with fittings, and even elevation changes were installed and operated. This provided



a consistent comparison between system designs, as well as an indication of the minimum performance characteristics of each system.

PEX piping was installed in each of the three configurations—trunk and branch, parallel, and zone—with overall results showing:

- All systems had similar flow characteristics at each of the fixtures when flowing independently
- All system designs responded in a similar manner to simultaneous flow events (more than one fixture flowing at once)
- Minor differences in the actual measured flow and pressure at a test fixture emerged when simultaneous flow events occurred

Test System Design and Set-up

A set of plumbing fixtures were installed in a laboratory setting to provide actual flow and pressure data during operation of the fixtures. These data provide assurance that the PEX plumbing system design is capable of supplying the required flow rates during operation of the fixture. In addition, the test results provide assurance that the plumbing system design will supply adequate flow and pressure to a remote test fixture while other fixtures are operated simultaneously. The test system was constructed and reconfigured for each type of PEX plumbing design, including the standard trunk and branch (T&B), the parallel (HR), and the zone (RM). A primary Test Fixture (TF), represented by a tub/shower unit, was installed and instrumented to measure flow rate and flow pressure on the hot and cold lines, as well as mixed water temperature. Figure 8.1 shows the laboratory system diagram for the T&B system. Other test system designs are shown in Appendix A. The TF was located the farthest from the source of all the fixtures, and was operated in shower mode during all tests. The operating performance of this test fixture represents the “worst case” characteristics of the full system, since all other fixtures were closer to the source. Figure 8.2 shows the laboratory set-up configured with the fixtures and the T&B system design with 100-foot distance to the TF. Figure 8.3 shows the TF with the sensors for pressure and flow installed.

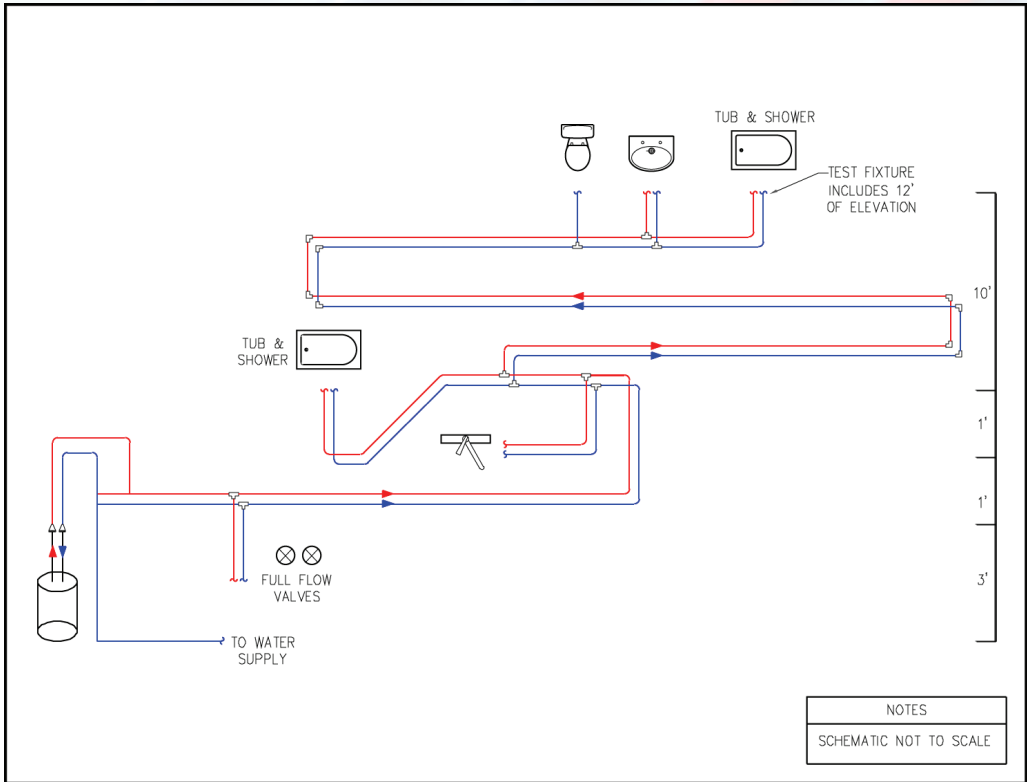

Figure 8.1 – Fixture Layout for Laboratory Testing



Figure 8.2 – Laboratory Test Set-up with Five Outlets, Hot Water Tank, and T&B System

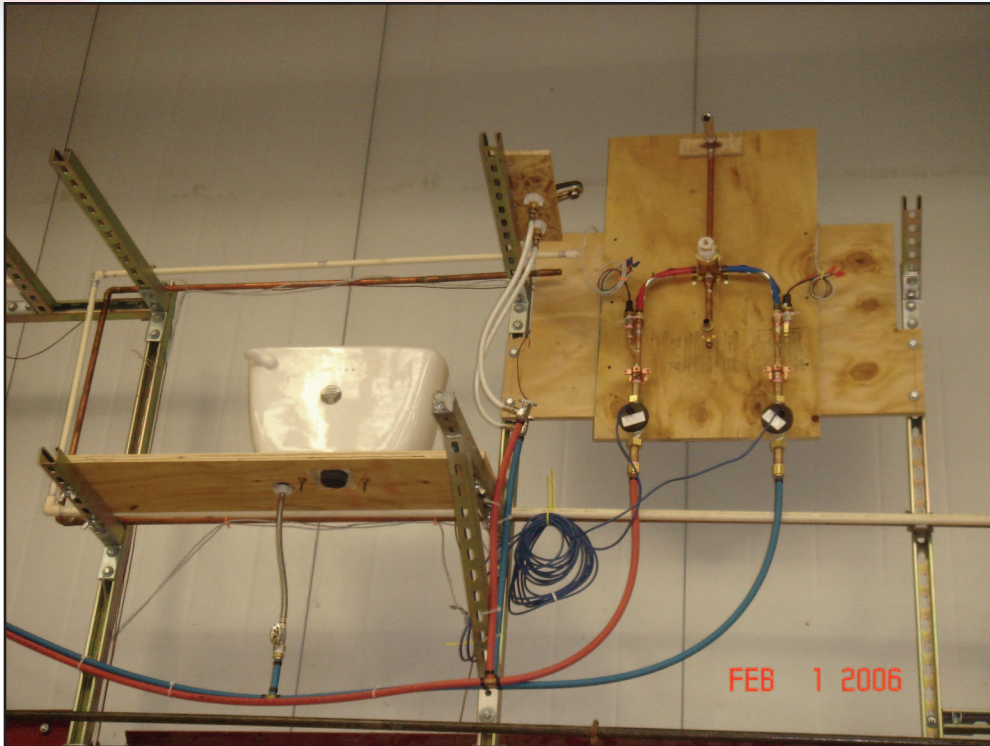

Figure 8.3 – The Test Fixture (Shower) with Flow and Pressure Sensors Installed

Table 8.1 shows the set of plumbing fixtures installed to represent specific residential outlets. These fixtures were connected to the three different PEX plumbing configurations. Tests included using two different total distances of pipe run to the farthest TF, 100 feet and 60 feet. The piping runs to the other fixtures were run in lengths that matched the type of piping system installed (i.e., if the HR system was being tested, all fixtures are plumbed with the HR system).

Table 8.1 – Plumbing Fixtures Installed in the Test Plumbing System			
Fixture	Length from Source (feet)	Elevation Above Source	Operation During Test
Tub/Shower TF	60 or 100	15	Full-On Shower
Lavatory	60 or 100	15	Intermittent
Water Closet (tank type)	55 or 95	15	Intermittent
Kitchen Faucet	Less than 40	5	Intermittent
Tub/Shower 2	Less than 40	6	Intermittent

Diagrams of all the test piping arrangements are shown in Appendix A.

Two sets of tests were performed for each plumbing system. One test recorded pressure and flow data at the TF, while other fixtures were operated. A second set of tests was performed to measure the length of time it took for hot water to reach the TF. The test was started after the piping was stabilized to the incoming water temperature.

Plumbing System Pressure and Flow Test Results

For all pressure and flow tests, the farthest shower fixture (TF) was operated in the shower “full-on” mode. The flow pressure and flow rates for each of the hot and cold water supplies to the TF were recorded. During the operation of the TF, other simultaneous flows were added as described in Table 8.2. For this, the TF flow and pressure data were recorded as well as the total hot and cold water supply to the other fixtures and the pressure at the base of the riser.

Table 8.2 – Pressure and Flow Test Regime

Test No.	Fixtures Operated	Nomenclature
1	Test Fixture (TF)	TF
2	TF and Lavatory	TF+Lav
3	TF and Water Closet	TF+WC
4	TF and Kitchen Faucet (mid-position)	TF+Kit
5	TF and 2nd Shower (full-on)	TF+Sh2
6	No. 5 and Kitchen	TF+Sh2+Kit
7	No. 6 and Lavatory	TF+Sh2+Kit+Lav
8	No. 7 and Water Closet	TF+Sh2+Kit+Lav+WC

Chapter 8 – PERFORMANCE DATA

Flow and pressure measurements were recorded for each of the tests and are recorded in Table 8.3. Each system was tested at three different static pressures measured at the base of the riser, 40, 60, and 80 psi. Table 8.3 shows the results of the TF flowing with no simultaneous fixtures operating.

Table 8.3 – TF Flow and Pressure Data for Each System					
System Type, Distance to TF, Riser Pressure	Riser Pressure	TF Hot Valve Flow	TF Hot Valve Pressure	TF Cold Valve Flow	TF Cold Valve Pressure
	psi	gpm	psi	gpm	psi
T&B, 100', 40 psi	40.0	1.7	31.6	0.2	35.1
Zone, 100', 40 psi	40.0	1.7	31.6	0.2	35.0
Parallel, 100', 40 psi	40.0	1.7	29.3	0.2	35.0
T&B, 100', 60 psi	60.0	2.2	50.0	0.3	55.2
Zone, 100', 60 psi	60.0	2.2	49.7	0.3	54.9
Parallel, 100', 60 psi	60.0	2.1	46.4	0.3	54.8
T&B, 100', 80 psi	80.0	2.6	68.7	0.3	75.1
Zone, 100', 80 psi	80.0	2.6	68.7	0.3	75.1
Parallel, 100', 80 psi	80.0	2.5	63.6	0.3	75.0
T&B, 60', 40 psi	40.0	1.8	32.0	0.2	35.1
Zone, 60', 40 psi	40.0	1.8	32.1	0.2	35.0
Parallel, 60', 40 psi	40.0	1.7	30.8	0.2	35.0
T&B, 60', 60 psi	60.0	2.2	50.8	0.3	54.9
Zone, 60', 60 psi	60.0	2.2	50.6	0.3	55.0
Parallel, 60', 60 psi	60.0	2.2	48.8	0.3	54.9
T&B, 60', 80 psi	80.0	2.6	69.9	0.3	75.2
Zone, 60', 80 psi	80.0	2.6	70.2	0.3	75.1
Parallel, 60', 80 psi	80.0	2.5	66.9	0.3	75.1

Note 1: **T&B** = Trunk and Branch;
 Note 2: Systems installed at either 100' or 60' to TF
 Note 3: Nominal Pressures of 40, 60, and 80 psi are static pressures

The performance data for each of the three system designs shows very similar performance for both the 100-foot distance to the TF and the 60-foot distance to the TF. At 100 feet from the source, the TF flow rate on the hot side of the valve was the primary flow and was 1.5 gpm at a low pressure of 40 psi (static). The flow rate at the valve increased to 2.4 gpm for the 60-foot distance with a riser pressure of 80 psi (static).

Once the baseline flow performance was verified for the TF, additional tests were performed adding simultaneous flows in conjunction with the TF flowing. The performance measure of the system capability to supply the farthest fixture is the flow and pressure data at the TF. Table 8.4 shows the performance data for the 100-foot tests with a source pressure of 40 psi.

Table 8.4 – Simultaneous Flow Performance Data – 100’ Maximum Length, 40 psi Source Pressure

Fixture Flow	Total System Flow	Cold Supply Flow	Hot Supply Flow	Main Pressure	Test Fixture (Shower)			
					Hot Flow	Hot Pressure	Cold Flow	Cold Pressure
					gpm	psi	gpm	psi
Trunk and Branch 100’ 40 psi Static	0.0	0.0	0.0	40.0	0.0	34.0	0.0	35.2
TF	2.1	0.5	1.6	40.0	1.7	31.6	0.2	35.1
TF+Lav	3.5	1.6	1.9	40.0	1.7	31.2	0.2	34.2
TF+WC	5.5	3.9	1.6	40.0	1.7	31.9	0.2	29.5
TF+Kit	3.5	1.3	2.2	40.0	1.7	31.3	0.2	35.0
TF+Sh2	4.2	1.3	2.9	40.0	1.7	30.6	0.2	34.9
TF+Sh2+Kit	5.6	2.2	3.4	40.0	1.7	30.3	0.2	34.7
TF+Sh2+Kit+Lav	7.0	3.5	3.5	40.0	1.7	30.1	0.2	33.4
TF+Sh2+Kit+Lav+WC	10.2	5.9	4.3	40.0	1.7	28.6	0.2	29.3
Zone 100’ 40 psi Static	0.0	0.0	0.0	40.0	0.0	33.9	0.0	35.2
TF	2.1	0.4	1.7	40.0	1.7	31.6	0.2	35.0
TF+Lav	3.5	1.4	2.1	40.0	1.7	31.1	0.2	34.6
TF+WC	5.5	3.9	1.6	40.0	1.8	32.0	0.2	31.8
TF+Kit	3.5	1.3	2.2	40.0	1.7	31.3	0.2	34.9
TF+Sh2	4.2	1.5	2.7	40.0	1.7	30.6	0.2	34.9

**Table 8.4 – Simultaneous Flow Performance Data –
100' Maximum Length, 40 psi Source Pressure** *(continued)*

Fixture Flow	Total System Flow	Cold Supply Flow	Hot Supply Flow	Main Pressure	Test Fixture (Shower)			
					Hot Flow	Hot Pressure	Cold Flow	Cold Pressure
					gpm	psi	gpm	psi
TF+Sh2+Kit	5.6	2.4	3.2	40.0	1.7	30.5	0.2	34.7
TF+Sh2+Kit+Lav	7.0	3.6	3.4	40.0	1.7	30.0	0.2	34.0
TF+Sh2+Kit+Lav+WC	10.2	6.2	4.0	40.0	1.7	29.8	0.2	30.8
Parallel 100' 40 psi Static	0.0	0.0	0.0	40.0	0.0	34.0	0.0	35.2
TF	2.1	0.4	1.7	40.0	1.7	29.3	0.2	35.0
TF+Lav	3.5	1.2	2.3	40.0	1.7	29.2	0.2	35.0
TF+WC	5.5	3.7	1.8	40.0	1.7	29.4	0.2	35.0
TF+Kit	3.5	1.2	2.3	40.0	1.7	29.0	0.2	35.0
TF+Sh2	4.2	1.5	2.8	40.0	1.7	28.6	0.2	35.0
TF+Sh2+Kit	5.6	2.3	3.3	40.0	1.7	28.6	0.2	34.9
TF+Sh2+Kit+Lav	7.0	3.3	3.7	40.0	1.7	28.4	0.2	34.8
TF+Sh2+Kit+Lav+WC	10.2	6.3	3.9	40.0	1.7	28.7	0.2	34.6

TF = Test Shower Fixture, 15' elevation; **Lav** = Lavatory, both valves open, 15' elevation
WC = Water Closet, tank type, 15' elevation; **Kit** = Kitchen, mid-position, 4' elevation
Sh2 = 2nd Shower, full open valve, 5' elevation

Based on the simultaneous flow performance data, all systems continued to supply adequate pressure and flow to the remote TF located 100 feet from the source. With the source pressure of 40 psi, the maximum system flow rate was 8.0 gpm; 5.0 gpm to the cold supply fixtures and 3.0 gpm to the hot supply fixtures. Table 8.5 shows similar results with a system design of 60 feet to the TF.

**Table 8.5 – Simultaneous Flow Performance Data –
60' Maximum Length, 40 psi Source Pressure**

Fixture Flow	Total System Flow	Cold Supply Flow	Hot Supply Flow	Main Pressure	Test Fixture (Shower)			
					Hot Flow	Hot Pressure	Cold Flow	Cold Pressure
					gpm	psi	gpm	psi
Trunk and Branch 60' 40 psi Static	0.0	0.0	0.0	40.0	0.0	34.1	0.0	35.2
TF	2.1	0.4	1.7	40.0	1.8	32.0	0.2	35.1
TF+Lav	3.5	1.4	2.1	40.0	1.7	31.6	0.2	34.5
TF+WC	5.5	3.9	1.7	40.0	1.8	32.1	0.2	31.2
TF+Kit	3.5	1.3	2.2	40.0	1.7	31.7	0.2	35.0
TF+Sh2	4.2	1.4	2.8	40.0	1.7	30.9	0.2	34.9
TF+Sh2+Kit	5.6	2.2	3.4	40.0	1.7	30.5	0.2	34.7
TF+Sh2+Kit+Lav	7.0	2.9	3.5	40.0	1.7	30.4	0.2	33.7
TF+Sh2+Kit+Lav+WC	10.2	6.0	4.2	40.0	1.7	29.2	0.2	30.0
Zone 60' 40 psi Static	0.0	0.0	0.0	40.0	0.0	34.0	0.0	35.2
TF	2.1	0.3	1.7	40.0	1.8	32.1	0.2	35.0
TF+Lav	3.5	1.3	2.2	40.0	1.7	31.7	0.2	34.8
TF+WC	5.5	3.9	1.6	40.0	1.8	32.3	0.2	33.1
TF+Kit	3.5	1.1	2.4	40.0	1.7	31.7	0.2	35.0
TF+Sh2	4.2	1.4	2.8	40.0	1.7	31.1	0.2	34.9
TF+Sh2+Kit	5.6	2.3	3.3	40.0	1.7	30.7	0.2	34.8
TF+Sh2+Kit+Lav	7.0	3.4	3.6	40.0	1.7	30.4	0.2	34.3
TF+Sh2+Kit+Lav+WC	10.2	6.2	4.0	40.0	1.7	30.4	0.2	32.0
Parallel 60' 40 psi Static	0.0	0.0	0.0	40.0	0.0	34.0	0.0	35.1
TF	2.1	0.4	1.7	40.0	1.7	30.8	0.2	35.0
TF+Lav	3.5	1.2	2.3	40.0	1.7	30.7	0.2	34.9
TF+WC	5.5	3.9	1.6	40.0	1.7	31.6	0.2	34.8
TF+Kit	3.5	1.4	2.2	40.0	1.7	30.6	0.2	34.9
TF+Sh2	4.2	1.4	2.8	40.0	1.7	30.2	0.2	34.9

**Table 8.5 – Simultaneous Flow Performance Data –
60’ Maximum Length, 40 psi Source Pressure** *(continued)*

Fixture Flow	Total System Flow	Cold Supply Flow	Hot Supply Flow	Main Pressure	Test Fixture (Shower)			
					Hot Flow	Hot Pressure	Cold Flow	Cold Pressure
					gpm	psi	gpm	psi
TF+Sh2+Kit	5.6	2.3	3.3	40.0	1.7	30.0	0.2	34.8
TF+Sh2+Kit+Lav	7.0	3.3	3.7	40.0	1.7	29.8	0.2	34.8
TF+Sh2+Kit+Lav+WC	10.2	6.5	3.7	40.0	1.7	30.3	0.2	34.5

TF = Test Shower Fixture, 15’ elevation; **Lav** = Lavatory, both valves open, 15’ elevation
WC = Water Closet, tank type, 15’ elevation; **Kit** = Kitchen, mid-position, 4’ elevation
Sh2 = 2nd Shower, full open valve, 5’ elevation

The system performance with simultaneous flows was very similar to the previous 100-foot test but with slightly lower pressure drops. A static pressure of 40 psi is considered to be a minimum supply pressure. A summary of the results for the simultaneous flow system performance at 60 and 80 psi source static pressure is shown in Appendix A.

Comparing the flow pressure and flow rate is a good way to determine the performance of a plumbing system. The limitation is that the pressure at the base of the riser is dependent on the size of the service line, meter, and water utility supply pressure. In order to describe and compare the performance of each type of system, the pressure drop from the base of the riser to the farthest outlet (including elevation losses) can be evaluated. Figures 8.4 and 8.5 show the comparison of pressure drop based on various outlets in the system flowing with the resultant pressure drop at the farthest fixture. Both figures indicate that the parallel system, while having a higher pressure drop to the TF, has a more consistent pressure drop during simultaneous flow. The other systems, based on the trunk line feeding branch lines, continued to show increasing pressure drop as more fixtures were added to the system. In fact, when the full set of fixtures was operating simultaneously, the trunk and branch system pressure drop exceeded that of the parallel and the zone configurations. (The zone system is highly dependent on the system design, i.e., the location of the manifolds and the number of fixtures connected to the manifold).

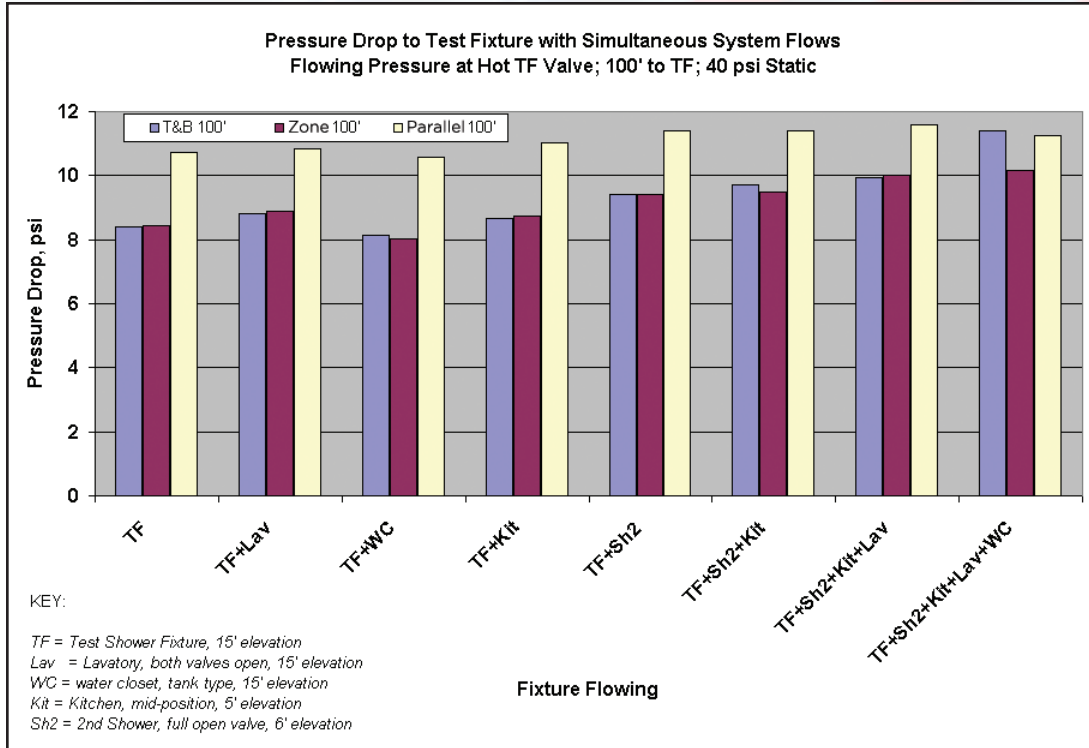

Figure 8.4 – Pressure Drop Comparison, 100' Distance to TF

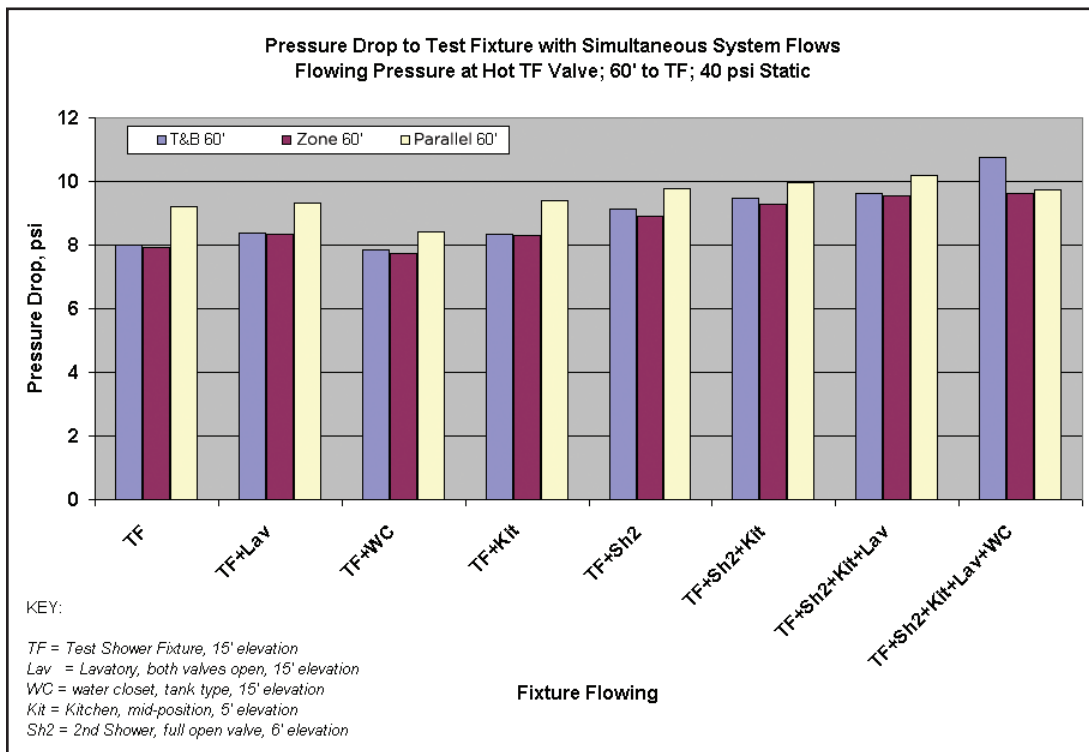

Figure 8.5 – Pressure Drop Comparison, 60' Distance to TF

Wait Time for Hot Water

A significant benefit of PEX piping systems is the opportunity to reduce water and energy waste by reducing the amount of time to deliver hot water to the outlet from the water heater. Though hard to quantify definitely, there are indications that hundreds of gallons of water per year are wasted while waiting for hot water to reach the outlet.

Tests were also performed on each of the three PEX system designs to compare the time it takes for hot water to be delivered to the test fixture (TF). Figure 8.6 shows the results of delivering hot water to the shower fixture after the pipes were flushed with cold (city) water. The results were normalized to keep the flow rates and temperature from the hot water tank constant for all systems.

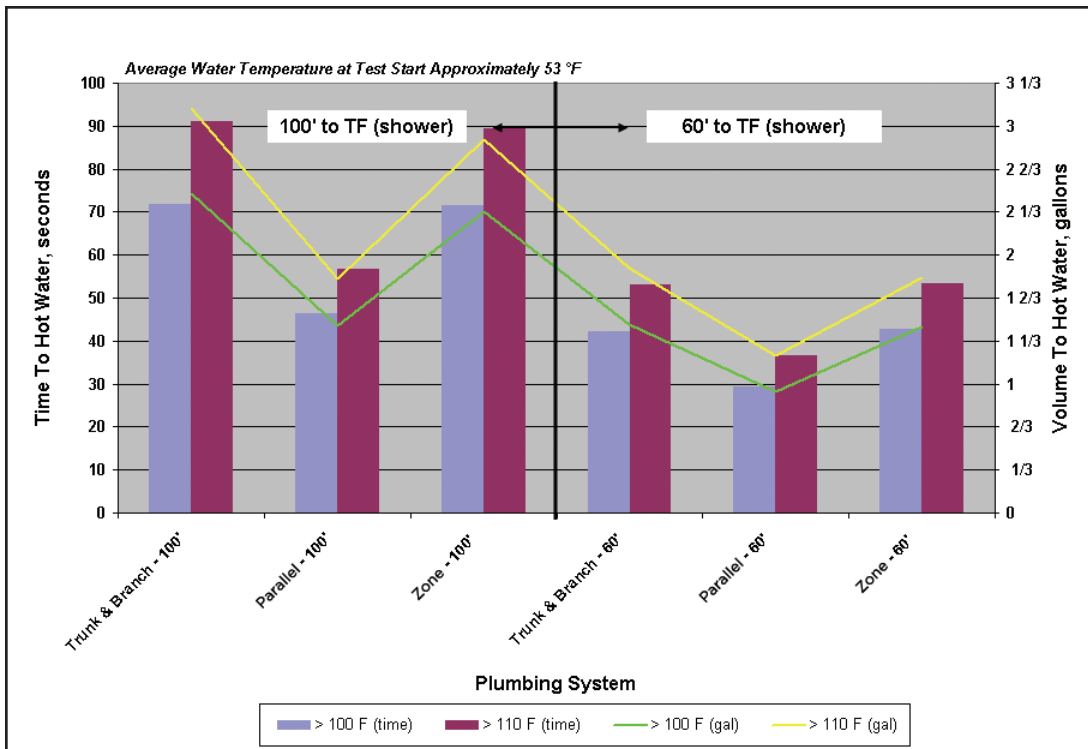

Figure 8.6 – Comparison of Hot Water Delivery Time

Water and time savings of between 30 percent and 40 percent were identified based on this analysis of the parallel system over either the trunk and branch or zone system designs.

Test Summary

A summary of the performance characteristics of each system is shown in Table 8.6. The data indicates:

- Trunk and branch and zone systems will supply one fixture at a higher pressure
- Parallel systems will supply a more stable pressure to each fixture when operating simultaneous fixtures
- Parallel systems will deliver hot water to the outlet quicker, especially when the pipes are at room temperature
- Trunk and branch and zone systems will deliver hot water quicker during sequential flows
- All three system designs will supply sufficient flow and pressure to the outlets even when the base riser pressure is 40 psi and the length to the farthest outlet is 100 feet.

Table 8.6 – Performance Summary, 100' Maximum Distance						
System	Test Fixture Only		Test Fixture With Simultaneous		Test Fixture Only	
	Flow Rate Hot	Pressure Hot	Flow Rate Hot	Pressure Hot	Time to > 100°F Hot Water	Time to > 110°F Hot Water
	gpm	psi	gpm	psi	sec	sec
40 psi Static						
T&B - 100'	1.7	31.6	1.7	28.6		
Zone - 100'	1.7	31.6	1.7	29.8		
Parallel - 100'	1.7	29.3	1.7	28.7		
60 psi Static					from 53°F	
T&B - 100'	2.2	50.0	2.1	44.4	71.9	90.9
Zone - 100'	2.2	49.7	2.1	46.3	71.6	89.3
Parallel - 100'	2.1	46.4	2.1	45.6	46.3	56.8
80 psi Static						
T&B - 100'	2.6	68.7	2.4	61.6		
Zone - 100'	2.6	68.7	2.5	63.0		
Parallel - 100'	2.6	63.6	2.4	62.0		

PEX Pipe Response to Surge Pressure (Water Hammer)

A benefit of flexible piping systems is the ability to mitigate or absorb pressure surges in plumbing systems, such as what can occur when flowing water is stopped by a fast-acting valve. To quantify this benefit, a test apparatus was constructed and operated such that pressurized flowing water in a 20-foot straight length of pipe was abruptly interrupted by a fast-acting solenoid valve. Several rigid and flexible, metal and plastic, nominal one-half inch diameter pipe materials were subjected to a test regime that included flow rates as high as 6 gallons per minute, using cold and hot water supplies.

Results of the pressure measurements taken at the location of the fast-acting valve showed that plastic pipe materials exhibited lower peak pressure measurements than copper pipe at all flow rates. The results were consistent for both cold and hot water tests.¹⁰

For example, test results using nominal half-inch pipes with “cold” water at a typical flow rate of 2.5 GPM showed that peak pressures were reduced by up to 37% for PEX pipes as compared with copper pipes. Test results using nominal half-inch pipes with “hot” water at a typical flow rate of 2.5 GPM showed that peak pressures were reduced by up to 33% for PEX pipes as compared with copper pipes. Results are shown in Tables 8.7 and 8.8. At higher flow rates, the percentage of the surge pressure reduction increases.

Table 8.7 – First Peak Pressure for Each Piping Material and Flow Rate (Cold Water)

Pipe Material	Maximum Measured Pressure, psi				
Flow Rate, gpm	2	2.5	3	4	6
1/2 inch Type L Copper	194	239	266	318	422
1/2 CPVC	155	173	201	222	296
1/2 PEX-1	143	168	177	212	274
1/2 PEX-2	136	150	169	193	244

Note: Pressure response measurements include 60 psi static pressure

Table 8.8 – First Peak Pressure for Each Piping Material and Flow Rate (Hot Water)

Pipe Material	Maximum Measured Pressure, psi				
Flow Rate, gpm	2	2.5	3	4	6
1/2 inch Type L Copper	149	181	204	250	306
1/2 CPVC	142	157	174	203	252
1/2 PEX-1	108	113	124	141	175
1/2 PEX-2	113	122	123	141	174

Note: Pressure response measurements include 60 psi static pressure



PEX and Copper Pipe Flow Rates

Laboratory testing was performed on identical configurations of PEX and copper trunk and branch (T&B) plumbing systems serving standard residential plumbing fixtures supplied at source pressures of 40, 60, and 80 psi, with lengths of 60 and 100-feet of pipe to the furthest fixture. The measured flow rate at each plumbing fixture was virtually identical for both piping systems, except for minor differences in the water closet fill rate.

Even though PEX tubing has a slightly smaller inside diameter than copper tubing of the same nominal dimension, both tubing systems satisfied the farthest fixture demand, even with multiple fixtures flowing. The following Table compares the two piping systems with a minimum source pressure of 40 psi, the most demanding scenario in the test Results of tests using higher pressures were consistent.

Results of this testing demonstrate that in a typical single-family residential plumbing system, both PEX and copper piping systems will deliver sufficient volumetric flow rates and pressures to the plumbing fixtures when using the same nominal size tubing.

Table 8.9 – Flow Performance Data, PEX and Copper, 100' Maximum Length, 40 psi Main Source Pressure

		Source						Farthest Test Fixture (Shower)							
Unit of Measure	System Type	System Flow		Cold Supply		Hot Supply		Hot Water Flow		Hot Water Pressure		Cold Water Flow		Cold Water Pressure	
		PEX	Copper	PEX	Copper	PEX	Copper	PEX	Copper	PEX	Copper	PEX	Copper	PEX	Copper
		GPM	GPM	GPM	GPM	GPM	GPM	GPM	GPM	psi	psi	GPM	GPM	psi	psi
T&B 100' Main Pressure															
TF		2.2	2.1	.5	.7	1.7	1.5	1.7	1.5	34.0	33.5			35.2	34.6
TF + Lav		3.5	3.6	1.6	1.7	1.9	1.9	1.7	1.5	31.6	32.5	.2	.5	35.1	34.4
TF + WC		5.7	6.2	4.0	4.8	1.6	1.4	1.7	1.5	31.2	32.1	.2	.5	34.2	34.1
TF + Kit		3.5	3.7	1.3	1.9	2.2	1.7	1.7	1.5	31.9	32.9	.2	.5	29.5	32.3
TF + Sh2		4.2	4.3	1.3	1.7	2.8	2.6	1.7	1.5	31.3	32.3	.2	.5	35.0	34.2
TF + Sh2+Kit		5.6	5.7	2.2	2.5	3.4	3.2	1.7	1.5	30.6	31.7	.2	.5	34.9	34.2
TF + Sh2+Kit+Lav		7.0	7.1	3.5	3.7	3.5	3.5	1.7	1.5	30.3	31.5	.2	.5	34.7	34.0
TF+Sh2+Kit+Lav+WC		10.0	10.9	5.8	6.9	4.2	4.0	1.7	1.5	28.6	30.9	.2	.5	29.3	31.5

GPM=Gallons Per Minute, psi=pounds per square foot, TF=Test Shower Fixture, Lav=Lavatory (sink), WC=Water Closet, Kit= Kitchen, Sh2=Shower 2

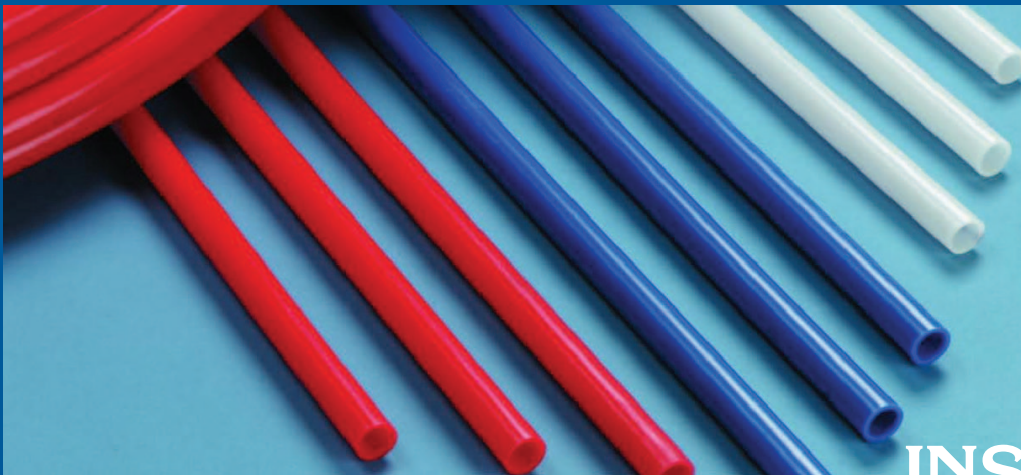

INSTALLATION

Cross-Linked Polyethylene (PEX) Hot- and Cold-Water Distribution Systems and Service Lines

Portions of this chapter have been extracted from the Plastic Pipe and Fittings Association (PPFA) document entitled “Cross-Linked Polyethylene (PEX) Hot- and Cold-Water Distribution Systems,” released in 2012, and are included with permission from the PPFA. It is provided as a general reference to supply basic information regarding the installation process for PEX piping in residential water service applications. It should not be used in place of the applicable manufacturers’ instructions for the installation of any particular system. Local codes may vary, and must be consulted before beginning any piping installation.

Important Notice

The information in this manual was gathered from publicly available sources, including reports of tests conducted by various independent entities under the test conditions specified in the standards listed. The contents of this manual are informational only and are not intended as an endorsement or warranty with respect to any product or system. The Plastic Pipe and Fittings Association (PPFA) and its members have no responsibility for the design, administration, results, or evaluation of any test. PPFA and its members make no warranties, express or implied, as to: the fitness of any product or system for any particular purpose; the suitability of any product or system for any specific application; or the performance of any product or system in actual construction.



Products or systems used or installed must meet all applicable plumbing or building code provisions as well as the manufacturer's installation or application instructions. Local code authorities and the product or system manufacturer should be consulted with respect to unresolved questions or uncertainties. In the event there is any conflict or inconsistency between the content of this manual and the applicable building or plumbing codes and the manufacturer's installation or application instructions, the codes and the instructions shall be followed.

Revision Policy

The PPFA Polyolefin Pipe Product Line Committee is responsible for proposing revisions of the manual. All suggestions and recommendations for revisions shall be addressed to the Committee, which shall respond to them as promptly as reasonably possible. The Committee shall review the manual in its entirety at least once every three (3) years.

Published by

Plastic Pipe and Fittings Association
800 Roosevelt Road
Building C, Suite 312
Glen Ellyn, IL 60137
www.ppfahome.org

Copyright © 2012 Plastic Pipe and Fittings Association

Manual Content & Use

This manual contains information on the installation of Cross-linked Polyethylene (PEX) tubing for hot- and cold-water distribution systems in residential and light commercial installations using tubing up to 2 inch diameter.

Information in this manual shall not be separated as it is often interrelated.

Consult local codes for additional installation requirements.

For additional information contact:

Local officials having jurisdiction (for codes)

Manufacturer (for specific product information)

PPFA (for general installation instructions)

Plastics Pipe Institute (PPI)

Other Uses of Cross-Linked Polyethylene (PEX) Tubing

- Residential and commercial potable cold- and hot-water distribution systems
- Residential fire protection systems
- Hydronic radiant heating and cooling, using warm or chilled fluids
- Outdoor snow and ice melting
- Outdoor turf conditioning
- Ice surface piping
- Hot-water distribution piping
- Hot-water baseboard piping
- Warm- and hot-water radiator connection piping
- Potable water service pipes
- Geothermal ground loop heat exchangers
- Chilled water piping
- Specialized industrial and mining applications

PEX is typically *not* used for refrigerant line piping or medical gas applications.

PEX is a unique material that provides many opportunities for new applications. Please discuss your application with any PEX manufacturer to determine if PEX is the material of choice for the application.

Consult tubing manufacturer for details.

Tubing Identification

Check the PEX tubing for the proper ASTM identification marking.

Use	ASTM Standard	Canadian Standard
Hot/Cold Water	F876 or F876 / F877 and Standard for Fittings	CSA B137.5

Check for potable water listing (NSF International [NSF-pw], or other recognized listing agency).

Marking	Typical Example												
Tube size	¾" CTS (0.875 O.D.)												
ASTM Standard	ASTM F876 or F876/F877												
Standard dimension ratio	SDR 9												
Pressure rating	160 psi @ 73.4°F, 100 psi @ 180°F												
*Marks of listing agencies	<table border="0"> <tr> <td>NSF–pw</td> <td>NSF International</td> </tr> <tr> <td>CSA</td> <td>CSA Group</td> </tr> <tr> <td>UPC</td> <td>IAPMO R&T</td> </tr> <tr> <td>UL</td> <td>Underwriters Laboratories</td> </tr> <tr> <td>ICC – ES PMG</td> <td>ICC Evaluation Services</td> </tr> <tr> <td></td> <td>or others</td> </tr> </table>	NSF–pw	NSF International	CSA	CSA Group	UPC	IAPMO R&T	UL	Underwriters Laboratories	ICC – ES PMG	ICC Evaluation Services		or others
NSF–pw	NSF International												
CSA	CSA Group												
UPC	IAPMO R&T												
UL	Underwriters Laboratories												
ICC – ES PMG	ICC Evaluation Services												
	or others												

**Note: Manufacturers may choose the agency (or agencies) with which they list. All of the examples shown are not required on an individual product.*

List of fittings standards with which tubing is compatible	Examples (ASTM F1807, F1960, F2080 or others)
Manufacturer name or trademark	Depends upon manufacturer
Production code	Depends upon manufacturer
Material Designation Code	Depends on product use See “designation code” section

Fitting Identification

All fittings shall be marked with manufacturer's name or trademark or other identification mark, plus the ASTM standard specification with which the fitting complies.

Applicable Standards

- ASTM F876 – Standard Specification for Cross-linked Polyethylene (PEX) Tubing
- ASTM F877 – Standard Specification for Cross-linked Polyethylene (PEX) Plastic Hot and Cold Water Distribution Systems
- ASTM F1807 – Standard Specification for Metal Insert Fittings Utilizing a Copper Crimp Ring for SDR 9 Cross-linked Polyethylene (PEX) Tubing and SDR 9 Polyethylene of Raised Temperature (PE-RT) Tubing
- ASTM F1960 – Standard Specification for Cold Expansion Fittings with PEX Reinforcing Rings for use with Cross-linked Polyethylene (PEX) Tubing
- ASTM F2159 – Standard Specification for Plastic Insert Fittings Utilizing a Copper Crimp Ring for SDR9 Cross-linked Polyethylene (PEX) Tubing and SDR 9 Polyethylene of Raised Temperature (PE-RT) Tubing
- ASTM F2080 – Standard Specification for Cold-Expansion Fittings With Metal Compression-Sleeves for Cross-Linked Polyethylene (PEX) Pipe
- ASTM F2098 – Standard Specification for Stainless Steel Clamps for Securing SDR9 Cross-linked polyethylene (PEX) Tubing to Metal Insert Insert and Plastic Insert Fittings
- CSA B137.5 – Cross-linked Polyethylene (PEX) Tubing Systems for Pressure Applications
- ANSI/AWWA C904-06 – AWWA Standard for Cross-Linked Polyethylene (PEX) Pressure Pipes 1/2 inch (12 mm) through 3 inch (76 mm) for Water Service
- NSF/ANSI 61 – Drinking Water System Components – Health Effects
- NSF/ANSI 14 – Plastic Piping System Components and Related Materials

Limitations on PEX Use

Do not use in applications where the temperature of the water could exceed 180°F at 100 psi unless specifically approved in the code, e.g., water heater relief line. See manufacturer's recommendations for higher operating temperatures at lower pressures.

Do not use in any application where tubing will be exposed to direct sunlight.

Do not allow tubing to come in extended contact with any of at least the commonly encountered construction materials listed below: (This list is not all-inclusive.)

- Pipe thread sealing compounds
- Fire wall penetration sealing compounds. *Exception: water soluble, gypsum-based caulking or other sealants approved by the PEX tube manufacturer*

- Petroleum-based materials or sealants such as:
 - Kerosene, Benzene, Gasoline, Solvents, Fuel Oils, Cutting Oils, Asphaltic Paint, and Asphaltic Road Materials, Acetone, Toluene, and/or Xylene

Consult your tubing manufacturer if you have questions about these or any other materials not listed.

Do not place any PEX tubing in heavily contaminated soils or other heavily contaminated environments.

Do not use tubing with gouges, cuts, cracks, abrasions, evidence of chemical attack, or other defects, or tubing that has been crushed or kinked.

Do not use PEX in swimming pool piping systems.

Copper or brass fittings, when used in a PEX piping system, have the same limitations as copper or brass fittings used in plumbing or heating systems.

Store fittings in containers that are free of oil, grease, lubricants, solder flux, or other chemicals and away from corrosive atmospheres (Example: Ammonia).

Designation Codes of ASTM F876

The tubing material designation code shall consist of the abbreviation for the type of plastic (PEX) followed by four Arabic digits that describe short-term properties in accordance with applicable ASTM standards.

The first digit is for chlorine resistance tested in accordance with Test Method F2023.

A digit “0” indicates that the PEX tubing either has not been tested for chlorine resistance or that the PEX tubing does not meet the minimum requirement for chlorine resistance.

A digit “1” indicates the PEX tubing has been tested and meets the F 876 requirement for minimum chlorine resistance at the end use condition of 25% at 140°F (60°C) and at 75% at 73°F (23°C). A digit “2” is reserved for future application.

A digit “3” indicates that the PEX tubing has been tested and meets the F 876 requirement for minimum chlorine resistance at end use condition of 50% at 140°F and 50% at 73°F.

A digit “4” is reserved for future application.

A digit “5” indicates that the PEX tubing has been tested and meets the requirement for minimum chlorine resistance at end use conditions of 100% of the time at 140o F.

The second digit is for demonstrated UV resistance of PEX material when tested in accordance with Test Method F2657. A digit “0” indicates that the PEX tubing either has not been tested for UV resistance or that the PEX tubing does not meet the minimum requirement for UV resistance. A digit “1” indicates that the PEX tubing has been tested and meets the requirements for 1 months exposure rating. A digit “2” indicates that the PEX tubing has been tested and meets the requirements for 3 months exposure rating. A digit “3” indicates that the PEX tubing has been tested and meets the requirements for 6 months exposure rating.

The last two digits are the hydrostatic design stress for water at 73°F (23°C) in units of 100 psi with any decimal figures dropped.

Where the hydrostatic design stress code contains less than two figures, a zero is used for the third digit.

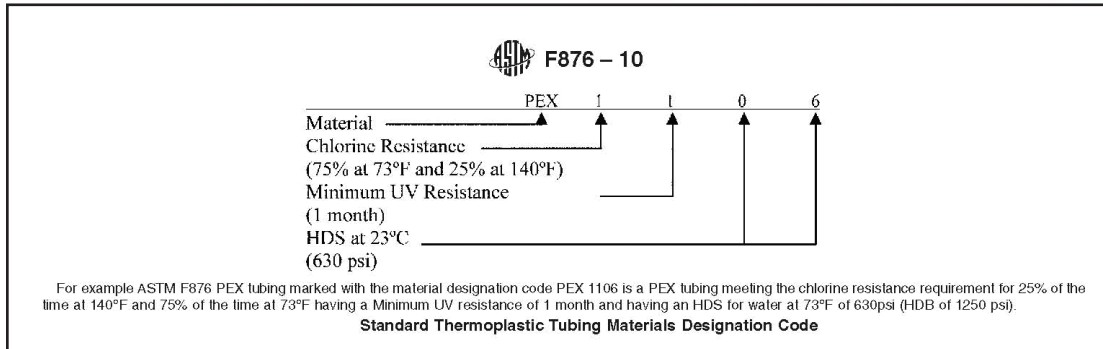

TUBING INSTALLATION PRACTICES

General Installation

Review all limitations on the use of cross-linked polyethylene tubing, and the fitting system you have selected to use.

Keep tubing a minimum of 12 inches vertically or 6 inches horizontally from sources of high heat, such as recessed light fixtures, flue gas vents, or heating appliances.

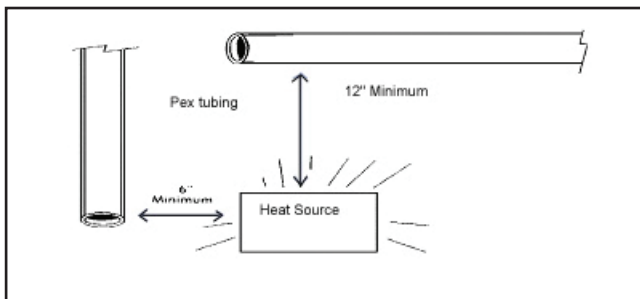

Do not install PEX tubing downstream of any point-of-use water heater or immersed coil heater in a boiler where the output temperature can exceed 180°F or closer than 6 inches upstream. Contact manufacturer for recommended metallic transition fittings.

PEX tubing may be connected directly to residential electric water heaters, if the local

code and manufacturer's instructions allow. When connecting PEX tube to gas water heaters, the tube must be kept at least 6 inches away from the exhaust vent of the heater. Flexible metal water heater connectors may be needed in some instances.

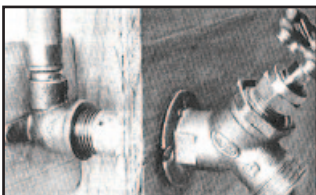

Hose bibbs shall not be supported by PEX tubing. Hose bibbs shall be anchored to prevent strain on PEX tubing.

Use only continuous length tubing (no fittings) when installing PEX under or within a slab. Protect PEX tubing with nonmetallic sleeves where it penetrates a slab or foundation. (Examples: PVC bend guides, PE sleeving). Protect tubing from nail damage where appropriate.

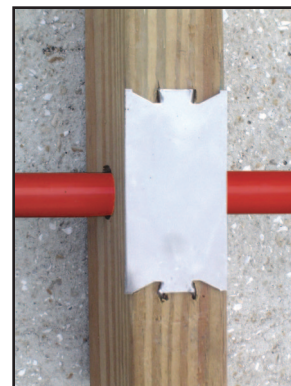

Nail plate

Bending the Tubing

Tubing Size (in. nominal)	Minimum Bending Radius (in.) CTS
3/8	4
1/2	5
3/4	7
1	9

The following recommended minimum bending radius values are based on 8xOD and should be considered a guideline, consult the manufacturer for product specific recommendations.

Using bend supports often allow for tighter bend radius.

NOTE: If using tubing in coils, and bending the tubing against the coil direction, the minimum bending radius is 3 times the radius given above (e.g., 3/8" tubing = 3 x 4 = 12").

Handling and Storing Tubing and Fittings



Do not drag the tubing over rough terrain, rocks, or any surface that can cut, puncture, or damage the tubing wall.



Do not crush or kink the tubing.

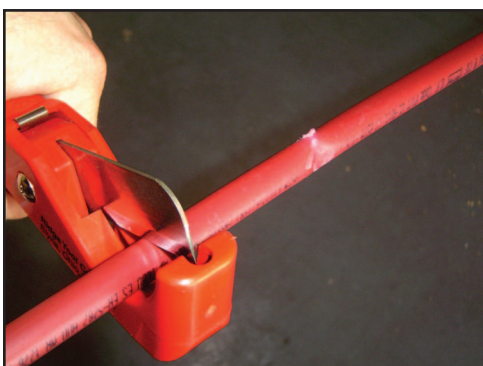

Inspect all tubing and fittings before and after installation. Cut out and replace all damaged sections or fittings.

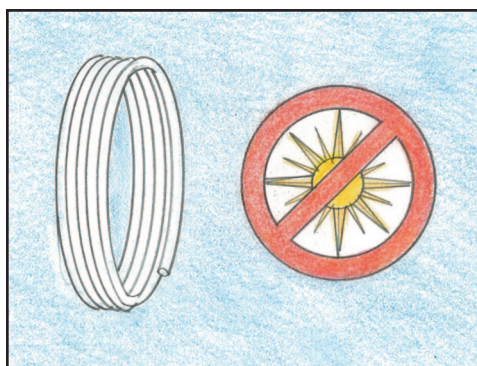

Tubing shall be stored in a way to protect the system from mechanical damage (slitting, puncturing, etc.). Tubing and fittings shall be stored undercover for cleanliness and to avoid exposure to sunlight. Consult manufacturer for recommended limits for outside storage.

TUBING SUPPORTS

Selection and Inspection

Plastic hangers and straps are recommended, but metal supports that are designed for use with plastic tubing can be used.

Do not use supports that pinch or cut the tubing. Support should allow free tubing movement.

Inspect all supports prior to installation to ensure that sharp edges do not exist that can damage the tubing.

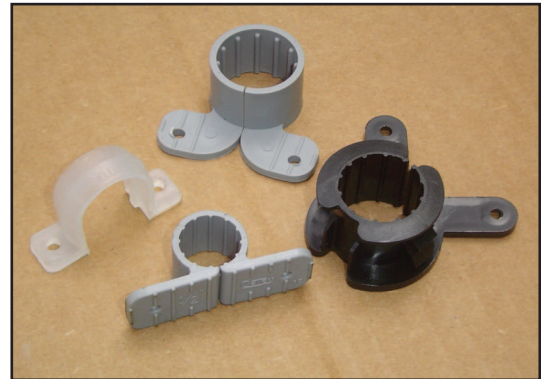
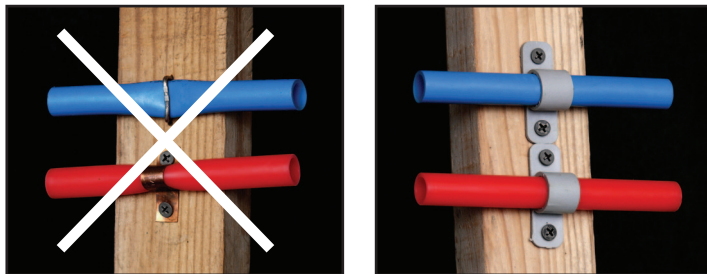

Support Spacing and Location

Horizontal Tubing Support Spacing

Nominal Tubing Diameter (inch)	Spacing (inch)
3/8, 1/2, 3/4, 1	32
1-1/4, 1-1/2, 2	48

Note: Some codes allow only up to 32”, check with your local AHJ before installing.

Vertical tubing shall be supported at every floor (8-feet to 10-feet height) and at the mid-floor guide between floors.

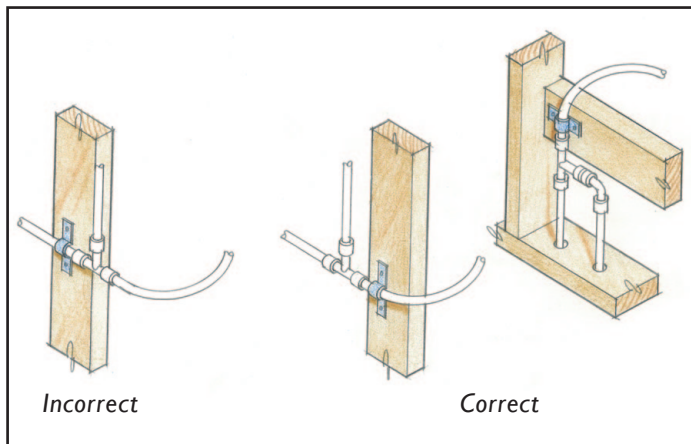

When penetrating metal studs, utilize a properly-designed bushing or sleeving material on all penetrations to protect tubing.

Tubing and fittings shall be installed without placing stress on the connection. Stress on connections frequently occurs when tubing is not properly strapped at changes of directions. See illustrations for proper methods.

Expansion/Contraction of Tubing

Do not pull tubing tight during installation. This can cause excessive tensile forces on fittings and connections when tubing cools and contracts. Allow 1/8-inch slack per foot of installed tubing. Expansion can usually be accommodated by the tubing's flexibility for sizes up to and including 1 inch. Expansion loops or offsets may be used if needed depending on installation and sizes used

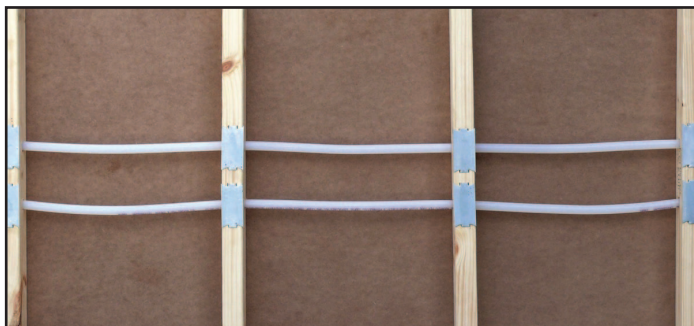

Allow 1/8-inch slack per foot of installed tubing.

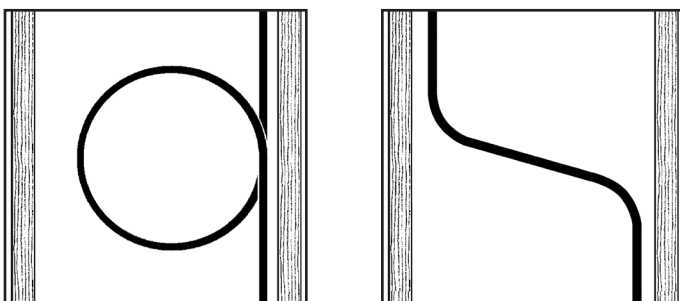

Expansion loops (left) and offsets (right) also provide means to accommodate tubing expansion and contraction.

Hydraulic Shock (Pressure Surge)

The following table provides the maximum pressure that will occur from rapid closure of a valve in the various tubing systems at a given velocity. The faster the velocity, the greater the potential hydraulic shock (pressure surge).

Excessive hydraulic shock (pressure surge) may result in audible water hammer with metallic piping systems, though this is highly unlikely with PEX tubing due to the flexibility of the tubing itself.

The table shows the additional hydraulic shock (pressure surge) that can occur in various types of pipes at the water velocities shown when a fast-acting valve closes. Hydraulic shock pressure is in addition to the system static pressure (measured on site). To determine the instantaneous total system pressure that occurs, add the hydraulic shock pressure to the static pressure.

Hydraulic Shock (psi at 73 F)				
Velocity (fps)	4	6	8	10
PEX	58	87	116	145
Copper	200	300	400	505
Galvanized Steel	240	360	475	595

For normal plumbing installations, water hammer arrestors are not necessary with a PEX tubing system.

In predominantly metal piping systems in which PEX is used, it may be necessary to install water hammer arrestors.

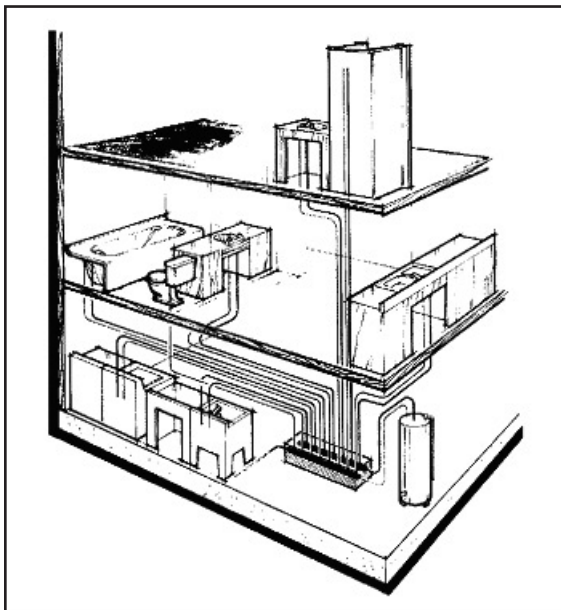

This drawing represents a typical manifold system

Parallel Water Distribution Manifold Plumbing (Parallel) Systems

Each faucet or water outlet is fed by its own dedicated line from the manifold. Manifolds for hot water should be installed near the water heater to minimize hot water delivery time. Manifolds shall be installed at least 36 inches away vertically, or 18 inches away horizontally from the water heater. A manifold for cold water only may be installed near the water supply.

The following information applies to a PEX tubing plumbing manifold system in addition to the general limitations and installation information on PEX tubing and fittings in this manual.

- Manifolds can be installed in a horizontal or vertical position.
- In larger installations, with multiple water heaters, use a manifold at each water heater for the fixtures served by the water heater.

- Tubing shall be run continuously and as directly as possible between manifold and fixture locations. Approved fittings may be used to repair kinked or damaged PEX distribution lines, or to add additional length to a distribution line that was mistakenly cut too short during installation.
- Shut-off valves may be placed at the manifold or at the fixture. Check with your local inspector for the local requirements.
- Tubing shall not be pulled tight. Leave slack to allow for expansion and contraction.
- Install tubing cautiously to avoid bending, kinking, or abrasion.
- Leave excess tubing at the beginning and end of runs for connection to fixtures and the manifolds.
- When running lines to a group of fixtures, they may be bundled together, but must be bundled loosely enough to allow individual tubing movement. Plastic ties may be used. Hot and cold lines may be bundled together but some jurisdictions do not permit this practice. Be sure to check with the local authority.
- Do not use tape when bundling tubing as it may restrict movement of tubing runs.
- When bundled lines pass through conventional structural members, cut a hole at the centerline of the member. Consult the applicable code for maximum allowable hole size.
- Identify and mark all lines at the manifold.
- Manifolds shall be accessible and protected from freezing and exposure to sunlight.
- Hot-water and cold-water manifolds shall be sized in accordance with the following table:

Nominal Size Internal Diameter (in.)	Maximum Demand (gpm)	
	Velocity of 4 fps	Velocity of 8 fps
3/8	1.2	2.5
1/2	2	5
3/4	6	11
1	10	20
1-1/4	15	31
1-1/2	22	44
2	26	52

- Individual fixture shutoff valves may be installed at the manifold if permitted by the local authority. If installed, they shall be identified as to the fixture being supplied.

- Individual distribution lines supplied from a manifold and installed as part of a parallel water distribution system shall be sized in accordance with the following table:

Minimum Sizes of Fixture Water Supply Lines in Manifold Systems	
Fixture	Minimum Pipe Size (in.)
Bathtubs and Whirlpool Tubs	1/2
Tub and Shower	1/2
Shower only (Single Head)	3/8
Bathroom Lavatory	3/8
Water Closet, Residential	3/8
Water Closet, Commercial	1/2
Kitchen Sink	3/8
Laundry Washing Machine	3/8
Utility Sink	3/8
Bar Sink	3/8
Urinal, Flush Tank	3/8
Urinal, Flush Valve	1/2

Retro-Fit Installations

PEX tubing is ideal for retro-fit applications. The flexibility of the product and continuous lengths allow for easier installation in existing walls and structures than traditional rigid piping systems. Several varieties of fitting adapters are available for simple transition between piping systems, such as solder, threaded, and polybutylene adapters. Also, PEX tubing is available in coils and straight lengths which are often used for easier installation in existing walls. Consult the manufacturer for available product offerings. The use of PEX in retro-fit applications should follow the same installation guidelines described in this manual as new construction regarding the use and design of the PEX system.

Thawing PEX Tubing Systems

PEX tubing systems should not be intentionally subjected to freezing.

Do not use open torch or excessive heat to thaw PEX tubing. Tubing failure or damage can result. Use a hot air gun or a blow dryer.

Heat (DO NOT USE A TORCH) must be applied directly to the frozen tubing section. Temperature on tubing shall not exceed 180°F.

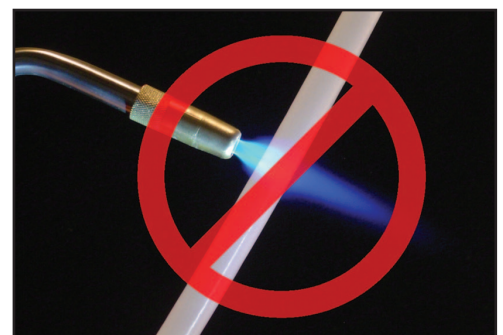

Several suitable methods exist to thaw PEX tubing. They include:

- A commercial system that pumps heated water through the tube to the ice blockage, and returns the cooled water for reheating
- Wet hot towels
- Hot water
- Hand-held hair dryer
- Low-wattage electrical heating tape

Pressure Testing and Inspection of the Completed System

Test system with water.

Test pressure shall be at least equal to the expected working pressure (main pressure), but not less than 40 psi and not greater than 200- psi at 73°F.

Compressed air or any other compressed gases should not be used for pressure testing plastic plumbing systems.

EXCEPTIONS:

For plastic piping systems specifically designed for use with compressed air or gasses;

- Manufacturers' instructions must be strictly followed for installation, visual inspection, testing and use of the systems, and
- Compressed air or other gas testing is not prohibited by the authority having jurisdiction (AHJ).

When compressed air or other gas pressure testing is specifically authorized by the applicable written instructions of the manufacturers of all plastic pipe and plastic pipe fittings products installed at the time the system is being tested and compressed air or other gas testing is not prohibited by the authority having jurisdiction (AHJ).

The manufacturer should be contacted if there is any doubt as to how a specific system should be tested.

Do not allow water in system to freeze.

Disinfection of Potable Water Systems

If disinfection of the system is required by code, and the conditions are not specified, the following procedures can be used.

Chlorine Concentration	Disinfection Period	Authority
50 to 100 ppm	3 hours	AWWA*
50 ppm	6 hours	ICC**

* American Water Works Association

** International Code Council

Select one the recommended test procedures.

Pre-mix the solution before injection into the system.

Thoroughly flush all lines of the system at the end of the disinfection period.

Failure to do so may damage the plumbing system.

Buried PEX Water Service Lines

Material

Plumbing codes approves the use of ASTM F876 and CSA B137.5 tubing within the jurisdiction of the code, generally meaning within the property line. PEX intended for use for municipal service lines (outside the property line) should be manufactured according to ANSI/AWWA C904. This standard describes cross-linked polyethylene (PEX) pressure pipe for water service.

Fittings

Consult PEX manufacturer for proper fittings for water service application.

Compression joint fittings or valves in accordance with AWWA C800 are compatible with PEX tubing. As with CTS polyethylene pipe, insert stiffeners are required.

Trench Preparation

Trench bottom shall be solid with no hollows, lumps, rocks, or other materials that could damage the tubing.

Laying the Tubing

Tubing should be laid with sufficient slack (snaking) to accommodate any contraction due to cooling prior to backfilling. Tubing will expand or contract approximately 1.00 inch in length for each 10°F change in tubing temperature for each 100 feet of tubing.

Minimum bending radius requirements for PEX tubing shall be followed. See “Bending the Tubing” Table.

Inspect tubing for damage. Remove and replace damaged sections.

In poor soil conditions, such as mud, rock, black gumbo, or clay, it is necessary to excavate deeper and use good clean fill or granular fill to smooth the trench bottom.

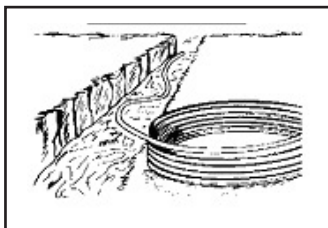

Correct

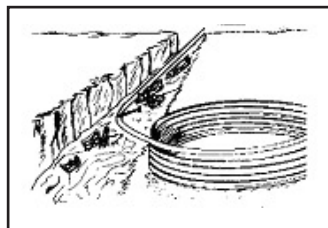

Incorrect

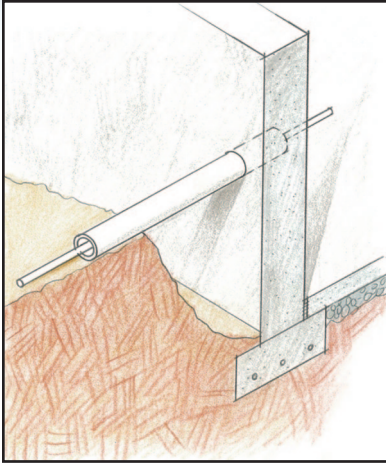

Penetrating Foundation or Basement Walls

When PEX is run through a basement or foundation wall, it must be protected by a rigid sleeve that spans the distance from within the wall out to the undisturbed soil in the pipe trench. The purpose of this protective sleeve is to prevent shearing of the PEX tubing at the wall in the event there is settlement in the backfill around the wall. At the point where the sleeve terminates inside the foundation or wall, the space between the PEX and the sleeve should be sealed to prevent leakage into the building.

Note: Petroleum-based caulks or sealants should not come in direct contact with PEX.

Slab-on-Grade Installation

Laying and Supporting Tubing under Slab

Only continuously-run lengths of tubing without fittings shall be used when installing PEX under a slab. All connections shall be outside or above the slab. Tubing shall be completely buried by a suitable, easily compacted, backfill material such as sand or pea gravel. PEX tubing should be installed under the rebar, re-mesh, or tensioning cables in the slab. PEX tubing shall be covered or fastened to prevent the tubing from floating or being pulled up to the slab surface.

PEX tubing does not have to be sleeved its entire length where it lies beneath a slab. PEX tubing shall be protected with a non-metallic sleeve where it comes through the slab. Because PEX is flexible, it may need support to keep it from falling back onto the slab once it exits the slab. To prevent this, PEX can be carefully tied to re-bar, wood stakes or rigid drain pipe for support. This will serve to protect the PEX tubing as the slab is poured, leveled and smoothed and from subsequent framing and construction work.

If termiticides or pesticides are applied to the soil all ends of the tubing should be closed or capped to prevent entry into the pipe. Also, it is important to ensure that no pooling or puddling of the termiticide or pesticide occurs in the spacing between any sleeving and PEX tubing at the slab penetration. This spacing should be filled with sealants that are compatible with PEX. Please reference PPI TN 39 *Recommended Practices Regarding Application of Pesticides and Termiticides Near PEX Tubing* for additional information.

Protection of Tubing and Fittings from UV Exposure after the Pour

Due to the nature of slab-on-grade installations, tubing and fittings may be exposed to UV light for unspecified periods of time after the slab is poured and before the structure is framed and enclosed. To prevent damage from UV exposure, PEX tubing and fittings that are exposed above the slab shall be wrapped with an opaque covering such as black polyethylene bags or sheeting immediately after the pouring of the slab. This covering should extend down to the surface of the slab to protect all of the tube above the slab from excessive UV exposure. For specific limitations on UV exposure, consult the PEX tube manufacturer.

Backfilling

Do not use clay, silt, or rocky backfill. Remove the construction materials, trash, or foreign objects from trench prior to backfilling.

The tubing and fittings should be surrounded with good clean fill, or sand, or river run gravel of 1/2-inch maximum particle size.

Compact the initial backfill around the tubing to provide adequate tubing support and prevent settlement. It is particularly important to adequately compact the soil around the tap connection.

It is recommended that the tubing be pressurized with water prior to backfilling to reveal any damage.

Technical Data

Tubing Dimensions and Weights

PEX Pipe Dimensions					
Nominal Diameter	OD	Wall	ID	Weight	Volume ³
	inches ¹	inches ²	inches	lb/ft	gallon/100ft
3/8"	0.500	0.075	0.350	0.04	0.5
1/2"	0.625	0.075	0.475	0.05	1.0
5/8	0.750	0.088	0.574	0.07	1.3
3/4"	0.875	0.102	0.671	0.10	1.9
1"	1.125	0.132	0.862	0.17	3.2
1 1/4"	1.375	0.161	1.054	0.25	4.7
1 1/2"	1.625	0.191	1.244	0.35	6.5
2"	2.125	0.248	1.629	0.60	11.1
¹ Average OD from ASTM F 876 ² Average wall thickness from ASTM F 876 ³ Typical pipe volumes in US gallons, not imperial					

Tubing water flow rate, velocity, and frictional losses are given in the following tables. Long-radius tubing bends have the same head loss as straight tubing.

Flow Rate and Velocity

Flow Velocity								
Flow Rate	Flow Velocity ft/sec							
GPM	3/8"	1/2"	5/8"	3/4"	1"	1 1/4"	1 1/2"	2"
0.5	1.67	0.91	0.62	0.45	0.27	0.18	0.13	0.08
0.75	2.50	1.36	0.93	0.68	0.41	0.28	0.20	0.12
1.0	3.33	1.81	1.24	0.91	0.55	0.37	0.26	0.15
1.5	5.00	2.72	1.86	1.36	0.82	0.55	0.40	0.23
2.0	6.67	3.62	2.48	1.81	1.10	0.74	0.53	0.31
2.5	8.34	4.53	3.10	2.27	1.37	0.92	0.66	0.38
3.0	10.00	5.43	3.72	2.72	1.65	1.10	0.79	0.46
3.5	11.67	6.34	4.34	3.18	1.92	1.29	0.92	0.54
4.0		7.24	4.96	3.63	2.20	1.47	1.06	0.62
4.5		8.15	5.58	4.08	2.47	1.65	1.19	0.69
5.0		9.05	6.20	4.54	2.75	1.84	1.32	0.77
6.0		10.86	7.44	5.44	3.30	2.21	1.58	0.92
7.0			8.68	6.35	3.85	2.57	1.85	1.08
8.0			9.92	7.26	4.40	2.94	2.11	1.23
9.0			11.16	8.17	4.95	3.31	2.38	1.39
10.0				9.07	5.50	3.68	2.64	1.54
11.0				9.98	6.05	4.04	2.90	1.69
12.0				10.89	6.60	4.41	3.17	1.85
13.0				11.79	7.15	4.78	3.43	2.00
14.0					7.70	5.15	3.70	2.16
15.0					8.25	5.52	3.96	2.31
16.0					8.80	5.88	4.22	2.46
17.0					9.35	6.25	4.49	2.62
18.0					9.90	6.62	4.75	2.77
19.0					10.45	6.99	5.02	2.92
20.0					11.00	7.35	5.28	3.08
25.0						9.19	6.60	3.85
30.0						11.03	7.92	4.62

Flow Velocity <i>(continued)</i>								
Flow Rate	Flow Velocity ft/sec							
GPM	3/8"	1/2"	5/8"	3/4"	1"	1 1/4"	1 1/2"	2"
35.0							9.24	5.39
40.0							10.65	6.16
45.0							11.88	6.93
50.0								7.70
55.0								8.47
60.0								9.24
65.0								10.01
70.0								10.78
75.0								11.55

Friction Losses

Type of Fitting	Equivalent Length of Tubing (ft.)			
	3/8" Size	1/2" Size	3/4" Size	1" Size
Coupling	2.9	2.0	0.6	1.3
Elbow 90°	9.2	9.4	9.4	10.0
Tee-branch	9.4	10.4	8.9	11.0
Tee-run	2.9	2.4	1.9	2.3

Friction losses stated are representative only, consult manufacturer for specific fitting friction losses of the connection system being used.

Pressure Loss and Flow Rate

Pressure Loss								
60°F (16°C) Water								
Flow Rate	Pressure Loss psi/100 ft of Pipe							
GPM	3/8"	1/2"	5/8"	3/4"	1"	1 1/4"	1 1/2"	2"
0.5	1.95	0.44	0.18	0.08	0.02	0.01	0.00	0.00
0.75	4.14	0.94	0.37	0.17	0.05	0.02	0.01	0.00
1.0	7.05	1.59	0.63	0.30	0.09	0.03	0.01	0.00
1.5	14.93	3.38	1.35	0.63	0.19	0.07	0.03	0.01
2.0	25.44	5.76	2.29	1.07	0.32	0.12	0.05	0.01
2.5	38.45	8.70	3.46	1.62	0.48	0.18	0.08	0.02
3.0	53.90	12.20	4.86	2.27	0.67	0.25	0.11	0.03
3.5	71.70	16.23	6.46	3.02	0.89	0.34	0.15	0.04
4.0		20.78	8.27	3.87	1.14	0.43	0.19	0.05
4.5		25.85	10.29	4.81	1.42	0.53	0.24	0.06
5.0		31.41	12.51	5.85	1.73	0.65	0.29	0.08
6.0		44.03	17.53	8.20	2.42	0.91	0.41	0.11
7.0			23.32	10.91	3.22	1.21	0.54	0.15
8.0			29.86	13.97	4.13	1.55	0.69	0.19
9.0			37.14	17.38	5.14	1.93	0.86	0.23
10.0				21.12	6.24	2.35	1.05	0.28
11.0				25.20	7.45	2.80	1.25	0.34
12.0				29.60	8.75	3.29	1.47	0.40
13.0				34.33	10.15	3.81	1.70	0.46
14.0					11.64	4.38	1.95	0.53
15.0					13.23	4.97	2.22	0.60
16.0					14.91	5.60	2.50	0.67
17.0					16.68	6.27	2.80	0.75
18.0					18.54	6.97	3.11	0.84
19.0					20.49	7.70	3.44	0.93
20.0					22.54	8.47	3.78	1.02
25.0						12.81	5.72	1.54

Pressure Loss <i>(continued)</i>								
60°F (16°C) Water								
Flow Rate	Pressure Loss psi/100 ft of Pipe							
GPM	3/8"	1/2"	5/8"	3/4"	1"	1 1/4"	1 1/2"	2"
30.0						17.95	8.01	2.16
35.0							10.66	2.87
40.0							13.65	3.68
45.0							13.98	4.57
50.0								4.56
55.0								6.63
60.0								7.79
65.0								9.04
70.0								10.37
75.0								11.78

Shown is pressure loss in units of psi per 100 feet of pipe.

Connection (Transition) to Other Piping Materials

Solder copper transition fittings onto the copper pipe and allow cooling before connecting to PEX tubing. High heat (greater than 180°F) may damage the PEX tubing.

Do not use plastic male pipe threads or non-gasketed plastic female pipe threads when making a connection to metal pipe threads. Use only manufacturer's recommended transition fittings.

When making connections to CPVC pipe or fittings, use only approved transition fittings.

Joining Procedures Utilizing Metallic or Polymer Insert Fittings

Insert Fitting with a Black Copper Crimp Ring (ASTM F1807 or ASTM F2159)

Making a PEX Crimp Connection

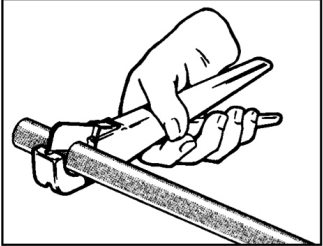
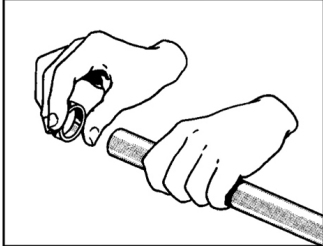
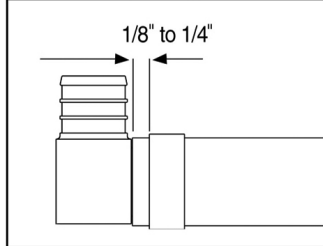
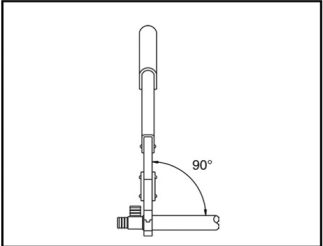
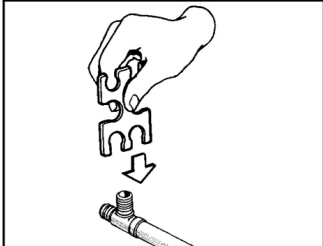
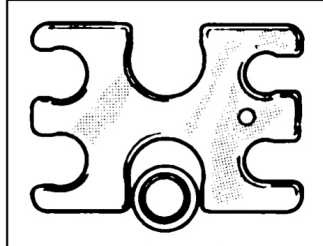
		
<p>1. Square off tubing to proper length. Uneven, jagged or irregular cuts will produce unsatisfactory connections.</p>	<p>2. Slide the correct size crimp ring over end of the tubing.</p>	<p>3. Insert the fitting into the pipe to the shoulder or tube stop. Position the ring 1/8" to 1/4" from the end of the tubing.</p>
		
<p>4. Center the crimping tool jaws exactly over the ring. Keep the tool at 90° and close the handles completely. DO NOT CRIMP TWICE.</p>	<p>5. When checking crimps with a GO/NO GO gauge, push the gauge STRAIGHT DOWN over the crimped ring. NEVER slide the gauge in from the side. Do not attempt to gauge the crimp at the jaw overlap area. The overlap area is indicated by a slight removal of the blackening treatment.</p>	<p>6. A crimp connection is considered good if the GO gauge fits the ring and the NO GO does not. A crimp connection is considered bad if the GO gauge does not fit the ring or the NO GO gauge does fit. Bad crimps must be cut out of the tubing and replaced.</p>

Making a Connection

Incorrect Connections

The consequence of not following correct procedures is a potential for leaks.

- Ring crimped over end of tube
Result: Doesn't cover enough ribs and/or tool could crush or crack fitting
- Tool not at 90 degrees to tube when crimped
Result: Insufficient rib coverage; tubing dented

- Ring not completely covered by crimp tool
Result: Ring distortion, non-uniform crimp
- Tubing not cut squarely
Result: Insufficient rib coverage
- Ring too far from pipe end
Result: Insufficient rib coverage

Tools and Rings

Use tools recommended by fitting and tubing manufacturers.

All tools must make a full-circle crimp.

Check tool adjustment at least daily and readjust as necessary.

Use only black-colored crimp rings designed for this PEX system.

Joining Procedures Utilizing ASTM F1960 Fittings and PEX Rings

1. Cut the PEX tubing perpendicular to the length of the tubing using a cutter designed for plastic tubing. Remove all excess material or burrs that might affect the fitting connection.
2. Slide the PEX Ring over the end of the tubing.
3. The PEX Ring should extend over the end of the tubing no more than 1/16 inch. The end of the tubing and inside of the PEX Ring must be dry and free of grease or oil to prevent the PEX Ring from sliding out of place during expansion.

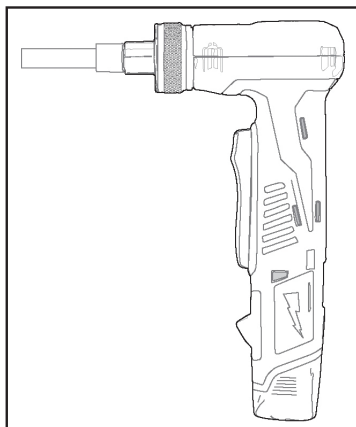
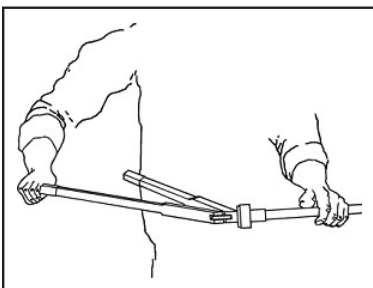

4. When using the hand expander tool, place the free handle of the tool against your hip, or place one hand on each handle when necessary. Fully separate the tool handles and insert the expander head into the end of the tubing until it stops. Be sure you have the correct size expander head on the tool. Full expansion is necessary to make a proper connection. Bring the handles together to expand. Separate the handles, remove the head from the tubing and rotate it 1/8 turn. Slide the tool head into the tubing in the newly rotated position and expand again.

IMPORTANT: Rotation of the expander head in either direction after every expansion is necessary to provide smooth and even expansion of the tubing. If you fail to reposition the head after each expansion, the segments of the tool head may cause deep grooves in the tubing, which could result in potential leak paths.

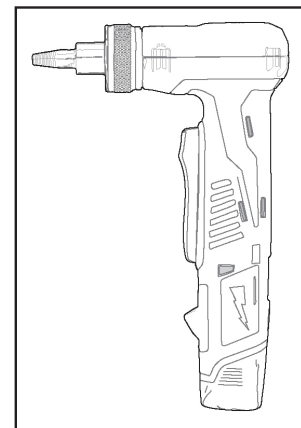
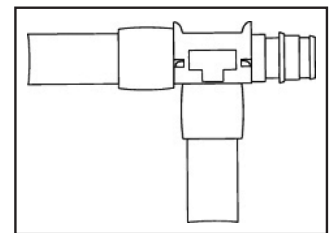

When using the battery expander tool, slide the expander head into the tubing until it stops. Full expansions are necessary to make a proper connection. Press the trigger to expand. The head for pipe sizes up to 1-1/2" will auto-rotate. For 2" pipe refer to the hand expander instructions.

5. Repeat the expansion process until the tubing and ring are snug against the shoulder on the expander head.
6. Immediately remove the tool and slide the tubing over the fitting until the tubing reaches the stop on the fitting. As you slide the tubing over the fitting, you should feel some resistance. If the tubing reaches the shoulder of the fitting without any resistance, the tubing may be over-expanded and may require additional time to fully shrink over the fitting. To ensure a proper connection, the PEX Ring must be seated up against the shoulder of the PEX fitting.
7. At minimum, ASTM F1960 connections must be pressure tested to the system's working pressure. PEX tubing and fittings are safe for air and hydrostatic testing. Refer to your local code for additional requirements.

ASTM F1960 Connections, Helpful Hints

- Holding the tubing in the expanded position increases the time it takes for the tubing to shrink around the fitting.
- The tubing should hold the fitting firmly after just a few seconds. If the fitting appears loose for more than a few seconds, the tubing has been over-expanded.
- If there is more than 1/16 inch between the PEX Ring and the fitting, square cut the tubing 2 inches away from the fitting and make another connection using a new PEX Ring.

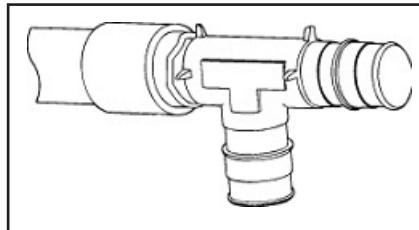

Incorrect

- Ring does not meet the pipe stops on the fitting. Tubing and rings should both meet the pipe stops on the fitting.

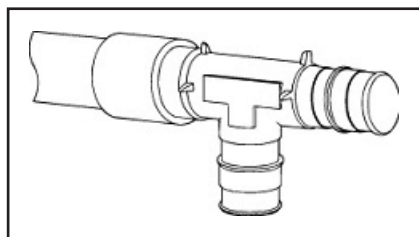

Incorrect

- Tubing does not meet the pipe stops on the fitting. Tubing and rings should both meet the pipe stops on the fitting.

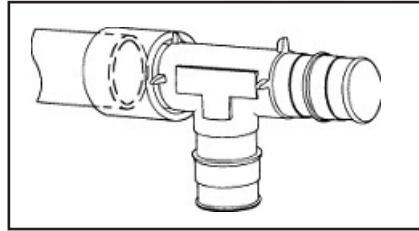

Incorrect

- Tubing and ring do not meet the pipe stops on the fitting. Tubing and rings should both meet the pipe stops on the fitting. Tubing is not cut square.

Tools

There are a variety of PEX expander tools that are designed for ease of use when making reliable, permanent connections.

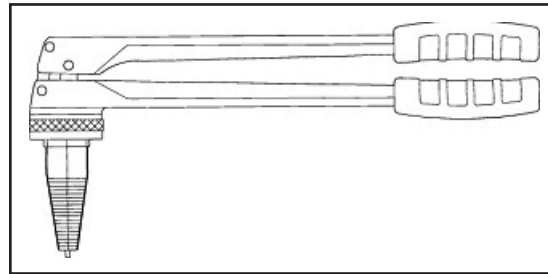
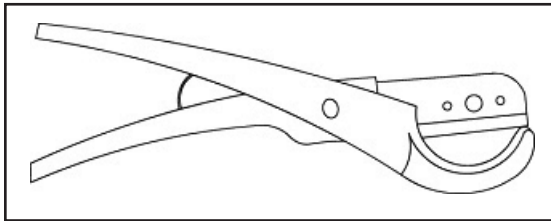

Joining Procedures Utilizing ASTM F2080 Fittings and Compression Sleeves

Summary

Fittings shall be joined to PEX pipe by first expanding the end of the pipe with the expander tool, inserting the cold-expansion fitting into expanded pipe, then pulling the compression-sleeve over the PEX pipe and the fitting, compressing the pipe between the compression sleeve and the fitting.

Procedure

1. Slide the compression sleeve onto the pipe so that the inside-beveled end is facing toward the end of the pipe. Slide the compression-sleeve far enough down the pipe so that it will not prevent expansion of the pipe.
2. Insert the head of the expander tool into the pipe. The expander tool segments shall be centered inside the pipe.

3. Fully expand the pipe, holding it open for approximately 3 seconds, and remove the tool. Rotate the pipe approximately 30°, insert the expander-tool into the pipe and repeat the expansion process. This ensures that the pipe is round inside.
4. The cold-expansion fitting should be inserted within 30 seconds of the expansion; otherwise the pipe will shrink back to its original size and become too small for fitting insertion. The fitting is properly inserted when the PEX pipe is pushed up against the last rib of the cold-expansion fitting. If full insertion is not possible, remove the cold-expansion fitting immediately and expand the pipe again for 3 seconds.
5. When the expansion is complete, and the cold-expansion fitting is inserted properly into the PEX pipe, the metal compression sleeve shall be pulled over the fitting with the compression tool (this may be the same tool as the expander tool or a separate tool).
6. Use the compression tool to pull the compression sleeve over the cold-expansion fitting and the PEX pipe end until the sleeve touches the collar of the fitting or until the tool stops.
7. The maximum allowable gap between the edge of the compression sleeve and the collar of the cold-expansion fitting shall be 0.040 inch. If this gap is too large, then repeat the compression step and/or adjust the tool.

Other Fitting Systems

Some PPFA Members have proprietary fitting systems for which ASTM standards have not been written. These systems are typically listed as meeting the performance requirements of ASTM F877 for PEX systems but their fitting dimensions and materials have not been specified in a standard. These fittings are typically available only through a single manufacturer and the components of the system do not interchange with similar looking parts from a different manufacturer. When using these systems, users are cautioned to be sure they do not mix components from different manufacturers even if they look the same.



TESTIMONIALS

Don Carpenter, Director of Product Development

Oakwood Homes of Denver, Colorado

As part of the Partnership for Advancing Technology in Housing (PATH) Program, administered by the U.S. Department of Housing and Urban Development (HUD), a Field Evaluation of technologies was conducted at Green Valley Ranch in Denver, Colo. According to Don Carpenter of Oakwood Homes, the company began using PEX piping with a central manifold and parallel system in 2000, after hearing of reduced labor, shortened construction cycle time, and decreased long-term costs. However, cost savings isn't the only reason the company chooses PEX pipe. "We look at it from a quality standpoint," said Carpenter, director of product development. "It's less money to install, and it's a superior plumbing system. For the homeowner, it's control over every fixture in the house, and the ability to easily adapt the plumbing when adding fixtures, building additions to the house, or finishing the basement." Oakwood saves the buyers an average of \$800 per home because of the PEX piping system chosen for the indoor plumbing system.

Rodney Ketzner, Plumbing Supervisor

Plumbing Specialists Inc., Wichita, Kansas

"The system goes in almost twice as fast as copper systems. After a new house has been framed, I walk through the house with the homebuyer to discuss fixtures and plumbing issues, including manifold plumbing systems using PEX. We offer conventional copper as an option but after I explain the system and the benefits it offers, homebuyers almost always choose it."

"My customers also like the quietness of the system. It's designed with both the homeowner and the plumbing contractor in mind."



Kenny Hodges, Owner

Hodges Plumbing, Blackshire, Georgia

“The owner said it was a good system and he’s right. I wish I had used it in my own home!”

Alan Boone, Plumber

Middleton Plumbing, Statesboro, Georgia

“My supplier mentioned that we could save a lot of time on installation with the PEX plumbing system. The PEX we used was much easier to install and required very few fittings. The red and blue color-coded pipe also made the installation go in quickly and easily identified hot and cold lines. It’s a great choice on large-scale projects. If we’d gone with copper, we’d still be there working.”

Tony Partusch, Shop Foreman

Partusch Plumbing, Anchorage, Alaska

“With our climate, copper doesn’t work very well. We see a lot of problems with copper sweat joints leaking. With PEX systems we’ve been able to eliminate 90 percent of the copper sweat joints in a system and now the chance of having a leak at a sweat joint is nearly nonexistent.”

“Usually you have to pay a lot more when you upgrade to a better product but PEX manifold plumbing systems are easy to sell because it’s a better product for about the same price.”

Jim Manning, President

Interstate Plumbing & Air Conditioning, Las Vegas, Nevada

“[PEX] tubing is clean, doesn’t corrode, and it’s not affected by corrosive water and soil. It even comes with a 25-year warranty. We wanted a system that would save us time, eliminate our copper theft problem, and ensure quality and reliability. [PEX] has proven itself to be a system that can do all this and more.”

Don George, Owner

Modern Plumbing, Portland, Oregon

“We’ve been installing [PEX] for years in custom homes. We utilize manifolds in most of our installations and our customers are continually impressed with how quiet the system is.”

Chris McGinnis, Owner

Tucson Plumbing and Heating, Tucson, Arizona

“The [PEX] connection is the most positive connection available. My plumbers can tell just by looking at the fitting if they’ve made a good connection. With [PEX], the installation is fast and easy, and the tubing can be buried directly in concrete—something the codes won’t allow us to do with copper. My plumbers like the ease of installation provided by the [PEX] fitting and the time savings that result. Rigid systems ... require more connections and more time without the assurance of a positive connection. With [PEX], we have eliminated many of our callbacks, which is also a nice benefit.”

Vince Lopoarchio and Levon Paul, Plumber and Project Foreman VHL Plumbing, Burbank, California

Second generation plumber Vince Lopoarchio states, “The best thing is there are no leaks so when we’re done we’re done.”

VHL and the developer benefited with consistent connections, no leaks, flexible pipe, no solder, no flux, and no flame which made for a cleaner, more secure, and faster installation process. Running 1 inch, 3/4 inch and 1/2 inch PEX tubing, four installers can complete four typical condo units per day, keeping VHL ahead of schedule.

Veteran installer and project foreman Levon Paul says, “The PEX system is very quiet so our customers are happy. It’s a pleasure working with this system after 30 years of working with copper. I would tell anybody that with [PEX] technology labor savings, the hand tools will pay for themselves on the first multi-unit job.”

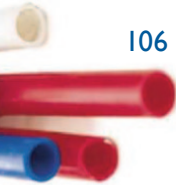



OTHER APPLICATIONS

Radiant Heating and Cooling Systems

Warm water or “hydronic” radiant heating systems utilize PEX pipes embedded within floors, walls or ceilings. Warm water is circulated through the pipe, which conducts heat to the panel, usually the floor. The warm floor then radiates heat to the space above it, warming the objects and people



Figure 11.1 – Radiant Floor Heating Piping in a Residential Application

in the room, while also allowing warm air to gently rise from the floor. The resulting comfort is unmatched with other forms of heat delivery. The warm water may be produced by a variety of heat sources such as

Figure 11.2 – Radiant Floor Heating Piping in a Commercial Application



high efficiency boilers, geothermal heat pumps and thermal solar collection systems. Benefits of radiant heating include increased efficiency, more uniform heat distribution in the lower portion of rooms, and easier zoning. Radiant heating systems are commonly found in all types of construction and applications, from houses to schools to hotels.

Some radiant heating systems also operate as cooling systems, circulating chilled water through floors, walls or ceilings in the cooling season to absorb heat energy from spaces. Radiant cooling systems improve comfort and efficiency, as the reduced cooling load on the traditional air-based system can be significantly reduced, lowering air movement, noise and drafts. The reduction in size of the air handling equipment is often enough to offset the cost of the PEX heating/cooling pipes. Radiant cooling systems are usually installed in commercial spaces where the humidity can be controlled by computerized control systems to manage air dehumidification and prevent condensation.

Municipal Water Service Pipe



Figure 11.3 – PEX Water Service

In addition to supplying water within a home or building, PEX pipe is also used to distribute water to buildings and entire communities through municipal water service pipes in sizes up to 3 in. Unlike buried metal pipes, PEX water service pipes will not corrode or suffer mineral build-up. Because PEX pipe has higher resistance to slow crack growth than other piping materials, it ensures high-impact resistance with normal backfill. PEX pipe is more flexible and resistant to freeze damage, lessening the chance of splitting or cracking. It provides excellent resistance to chlorine and chloramines, reducing risk of damage due to disinfectants. It connects to standard compression

joint valves, and fittings, so it's easy and convenient to install. Finally, PEX water service pipes can save up to half the cost of copper—a significant savings for budget-constrained waterworks professionals.

Snow and Ice Melting Systems

PEX pipes are often used in hydronic systems designed to augment the removal of snow and ice by circulating a heat transfer fluid (usually glycol and water) through pipes installed within outdoor surfaces. The durability and flexibility of PEX pipes designed for these applications allows these systems

Figure 11.4 – Snow and Ice Melt Piping for a Driveway

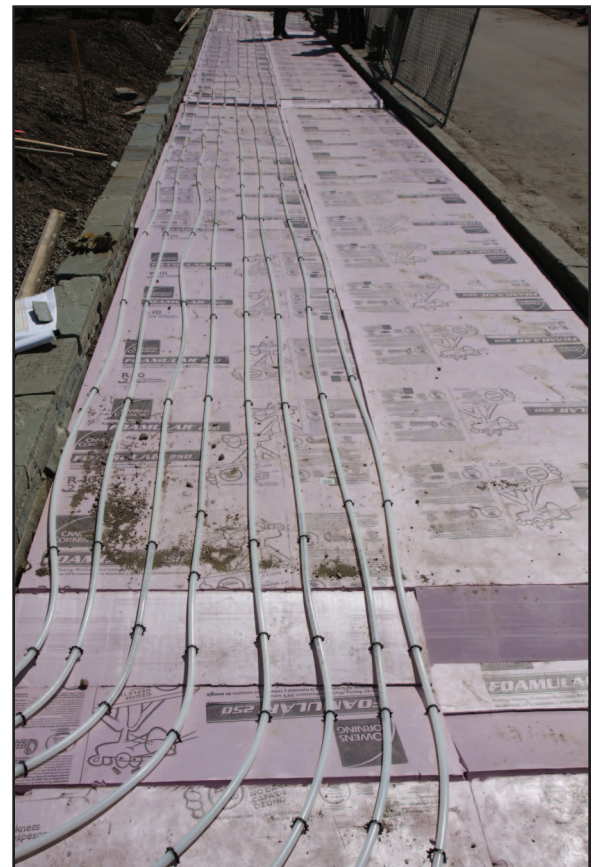

to provide years of reliable service, with no worries about pipe corrosion or failing electrical connections. Common applications of hydronic SIM systems include driveways, steps, sidewalks, hospital entrances, parking garage ramps, wheelchair ramps, car washes, hot tub/pool surrounds, and even helicopter landing pads. Benefits include safety, access, reduced maintenance costs, no snow removal costs, reduced liability, and obvious convenience.

Turf Conditioning

For outdoor playing surfaces like football, baseball and soccer fields, reliable PEX pipe is installed within the soil layer of the natural turf. Fluid is circulated at varying temperatures to gently warm the grass roots to provide optimal root zone temperature. These systems can extend the growing season of natural grass surfaces for use in late autumn and even winter, allowing the fields to recover faster after use. The systems will also melt snow, keeping playing surfaces accessible. Turf conditioning systems have been used for decades in European soccer fields, and are widely used across North America in playing fields used in the NFL and MLB, in golf courses and other sports field surfaces. Similar systems are also used in greenhouse applications with bedding plants and other foliage.



Figure 11.5 – Snow and Ice Melting in a Commercial Application

Geothermal Earth Energy Systems



Most geothermal ground source, or “earth energy”, systems utilize buried pipes as the ground heat exchanger, transferring heat to and from the earth

Figure 11.7 – PEX Piping in a Geothermal Application

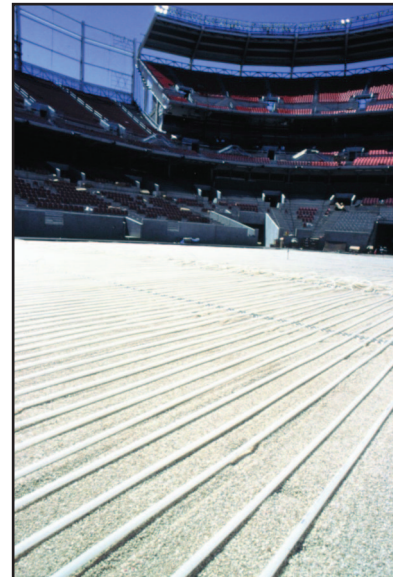

Figure 11.6 – Turf Conditioning in a Stadium

during cooling and heating operation, respectively. Ground source geothermal systems have the potential to reduce heating costs by 70% and cooling costs by 50%, or more, as compared to other sources of heating and cooling energy. PEX pipes are ideally suited for these applications, due to their flexibility, toughness and proven longevity. The flexibility of PEX assists installation in curved trenches, its high resistance to slow crack growth provides resistance to damage in both vertical and horizontal applications, its smooth interior permits excellent flow of heat transfer fluids, and its long-term history in pressurized applications ensures reliability, even when buried in the ground.



Figure 11.8 – Fire Sprinkler with PEX Piping

Fire Suppression

UL-approved PEX piping and fitting systems listed to UL Standards can be used to supply water to fire suppression sprinklers for residential applications. While many sprinkler systems are largely independent from the water distribution system, for some building types they can be combined with a building's cold-water plumbing system. This has the potential to reduce installation costs and the total amount of installed pipe and fittings. Sprinklers, PEX piping, and fittings must comply with National Fire Protection Association

(NFPA) requirements for residential fire sprinkler systems. Already, several PEX systems meet the requirements of NFPA 13D for domestic applications. Local codes must be consulted when implementing any fire suppression system to ensure that PEX and/or combined systems are permitted for each building type.

Water Reuse/Reclaim

Reclaim water systems reuse greywater, commonly defined as wastewater from bathtubs, shower drains, sinks, washing machines, and dishwashers. Greywater accounts for 60% of the outflow produced in homes. By designing plumbing systems to separate it from blackwater, greywater can be recycled for irrigation, toilets, and exterior washing, resulting in water conservation. Certain PEX pipe and fitting systems are intended for reclaim water systems and may contain special color codes or marking on the products to indicate this application. Be sure to consult your local codes, the Authority Having Jurisdiction and the pipe and fitting manufacturer when selecting a PEX piping systems for reclaimed water systems.



Figure 11.9 – Purple PEX for Water Reuse Applications

Appendix

PERFORMANCE TEST SETUP AND DATA

Diagrams of piping layouts for different test runs.

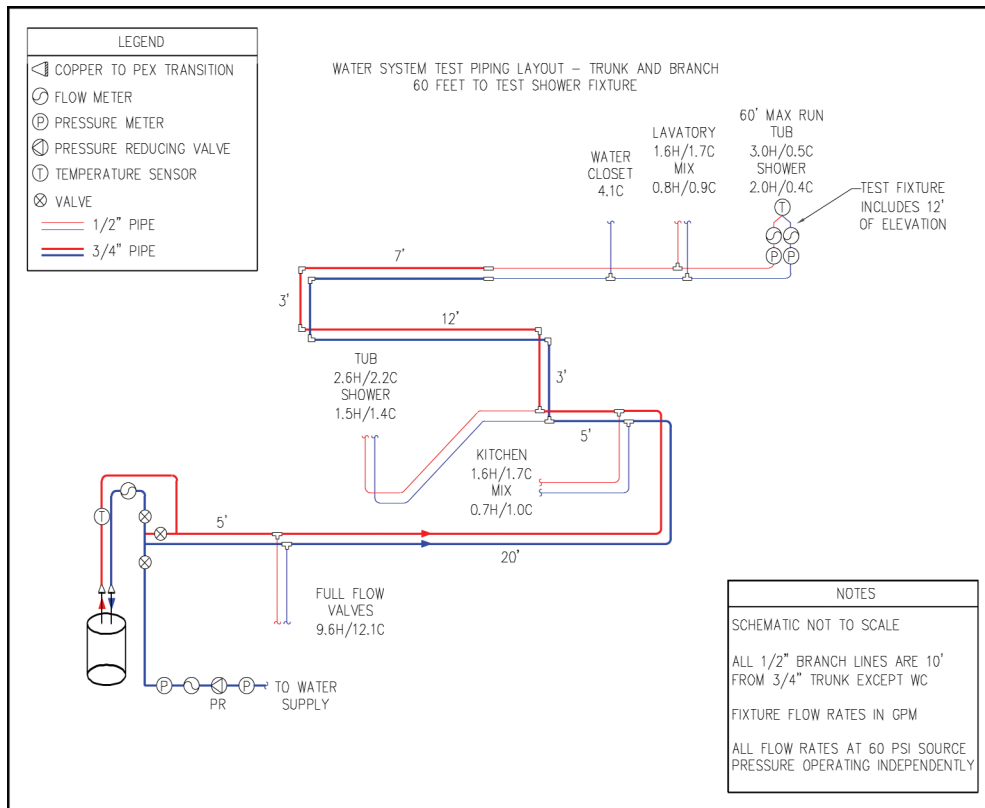

Figure A.1 – Water System Test Piping Layout – Trunk and Branch, 60' to TF

Appendix A – PERFORMANCE TEST SETUP AND DATA

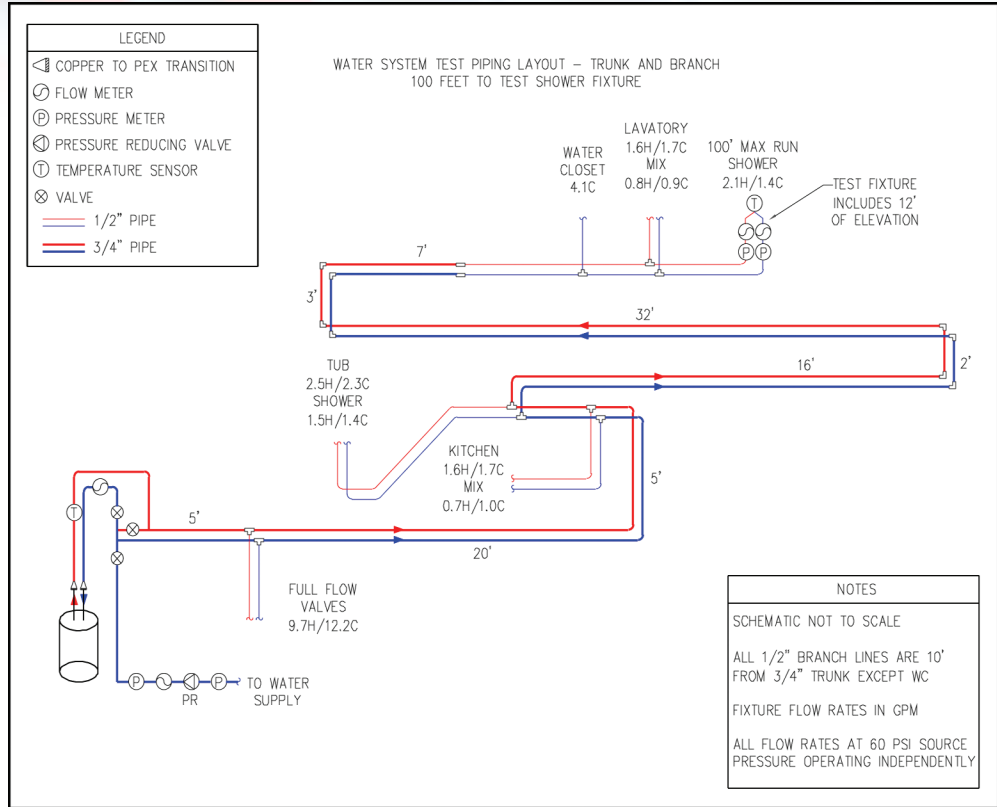

Figure A.2 – Water System Test Piping Layout – Trunk and Branch, 100' to TF

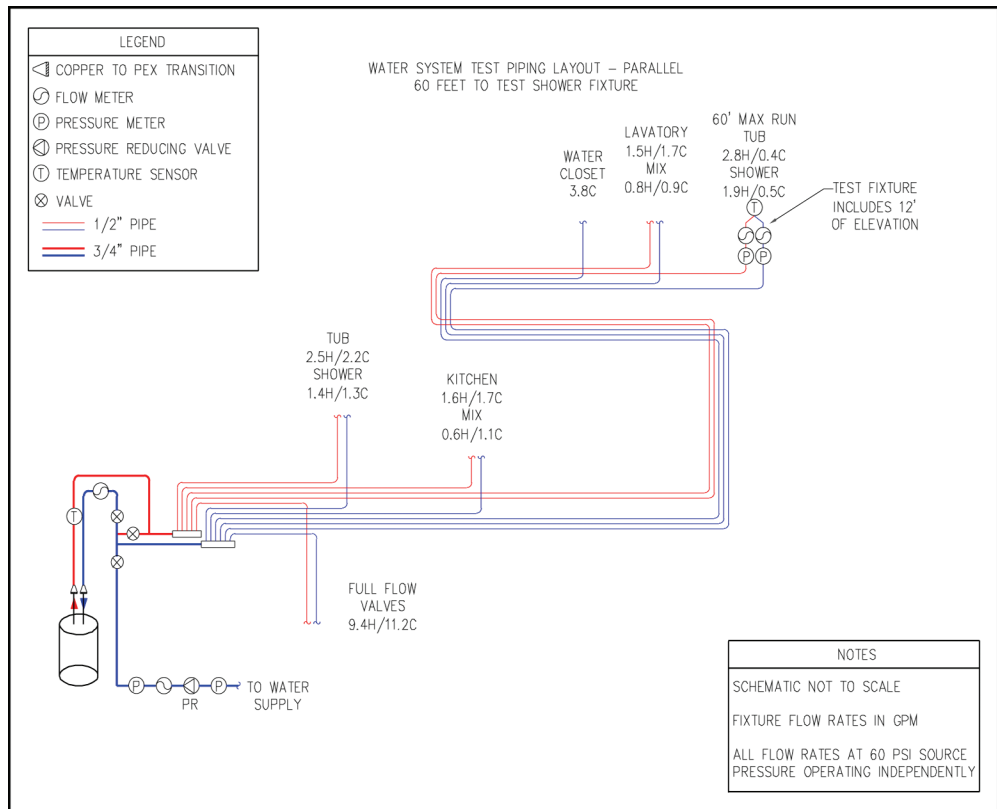

Figure A.3 – Water System Test Piping Layout – Parallel, 60' to TF

Appendix A – PERFORMANCE TEST SETUP AND DATA

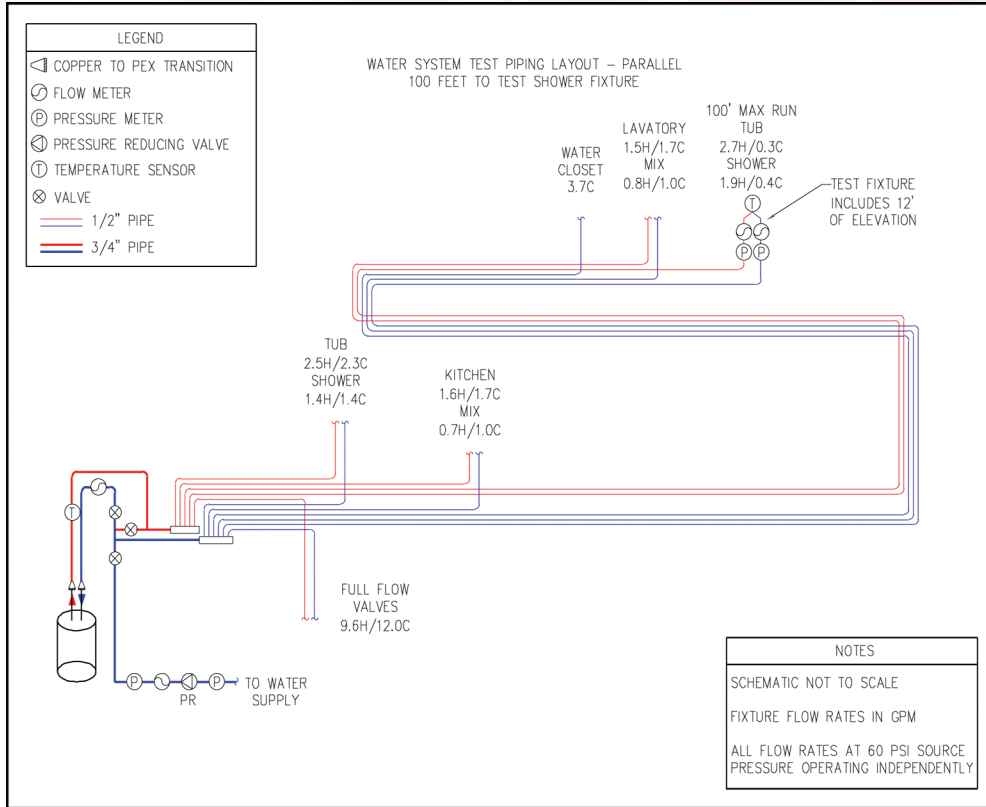

Figure A.4 – Water System Test Piping Layout – Parallel, 100' to TF

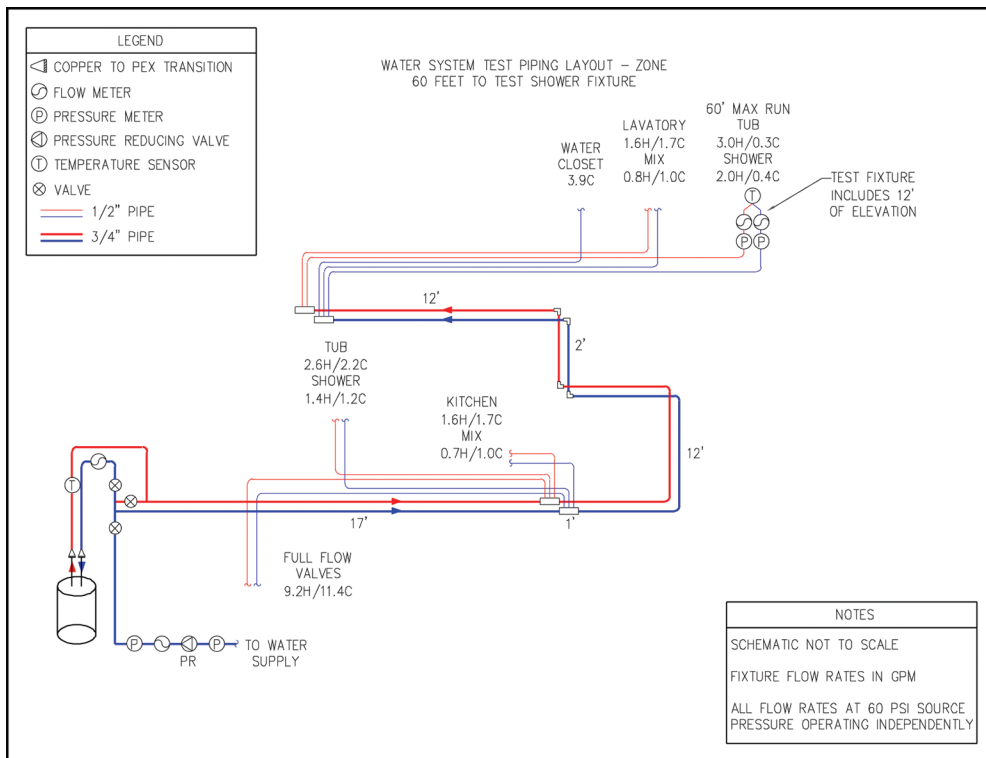

Figure A.5 – Water System Test Piping Layout – Zone, 60' to TF

Appendix A – PERFORMANCE TEST SETUP AND DATA

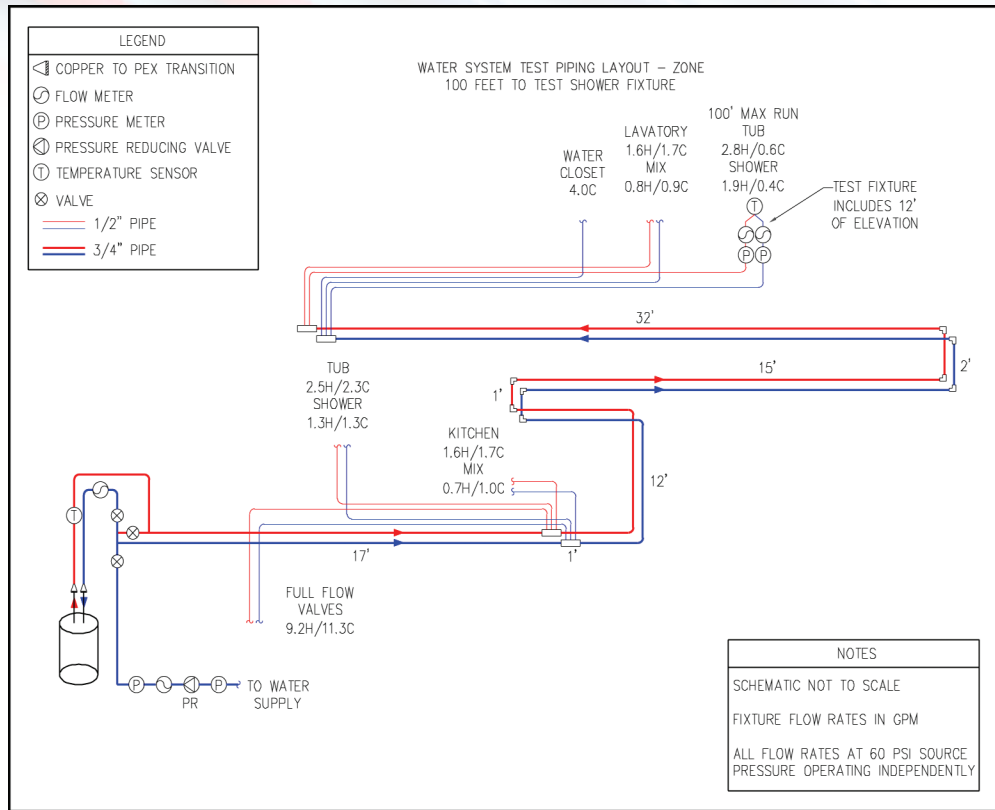

Figure A.6 – Water System Test Piping Layout – Zone, 100' to TF

Table A.1 – Simultaneous Flow Performance Data – 100' Maximum Length, 60 and 80 psi Source Pressure

Fixture Flow	Total System Flow	Cold Supply Flow	Hot Supply Flow	Main Pressure	Test Fixture (Shower)			
					Hot Flow	Hot Pres.	Cold Flow	Cold Pres.
					gpm	psi	gpm	psi
Trunk and Branch 100' 60 psi Static	0.0	0.0	0.0	60.0	0.0	54.3	0.0	55.4
TF	2.5	0.5	2.1	60.0	2.2	50.0	0.3	55.2
TF+Lav	4.3	1.8	2.5	60.0	2.2	49.1	0.3	53.5
TF+WC	6.8	4.6	2.2	60.0	2.2	50.1	0.2	46.5
TF+Kit	4.3	1.5	2.8	60.0	2.2	49.2	0.3	54.9
TF+Sh2	5.2	1.6	3.6	60.0	2.1	47.9	0.3	54.8
TF+Sh2+Kit	6.9	2.7	4.2	60.0	2.1	47.4	0.3	54.5
TF+Sh2+Kit+Lav	8.6	4.2	4.4	60.0	2.1	47.1	0.3	52.1
TF+Sh2+Kit+Lav+WC	12.5	7.2	5.3	60.0	2.1	44.4	0.2	44.5

**Table A.1 – Simultaneous Flow Performance Data –
100’ Maximum Length, 60 and 80 psi Source Pressure** *(continued)*

Fixture Flow	Total System Flow	Cold Supply Flow	Hot Supply Flow	Main Pressure	Test Fixture (Shower)			
					Hot Flow	Hot Pres.	Cold Flow	Cold Pres.
					gpm	psi	gpm	psi
Zone 100’ 60 psi Static	0.0	0.0	0.0	60.0	0.0	54.2	0.0	55.2
TF	2.5	0.5	2.1	60.0	2.2	49.7	0.3	54.9
TF+Lav	4.13	1.7	2.6	60.0	2.2	49.0	0.3	54.1
TF+WC	6.8	4.7	2.1	60.0	2.2	50.1	0.2	49.6
TF+Kit	4.3	1.6	2.7	60.0	2.2	49.1	0.3	54.8
TF+Sh2	5.2	1.7	3.5	60.0	2.2	48.4	0.3	54.7
TF+Sh2+Kit	6.9	2.8	4.0	60.0	2.1	47.9	0.3	54.3
TF+Sh2+Kit+Lav	8.6	4.2	4.4	60.0	2.1	47.2	0.3	53.1
TF+Sh2+Kit+Lav+WC	12.5	7.4	5.1	60.0	2.1	46.3	0.2	47.8
Parallel 100’ 60 psi Static	0.0	0.0	0.0	60.0	0.0	54.1	0.0	55.1
TF	2.5	0.5	2.1	60.0	2.1	46.4	0.3	54.8
TF+Lav	4.3	1.5	2.8	60.0	2.1	46.3	0.3	54.7
TF+WC	6.8	4.6	2.1	60.0	2.1	47.1	0.3	54.6
TF+Kit	4.3	1.4	2.9	60.0	2.1	46.2	0.3	54.7
TF+Sh2	5.2	1.7	3.5	60.0	2.1	45.7	0.3	54.7
TF+Sh2+Kit	6.9	2.7	4.1	60.0	2.1	45.3	0.3	54.6
TF+Sh2+Kit+Lav	8.6	3.9	4.7	60.0	2.1	45.0	0.3	54.4
TF+Sh2+Kit+Lav+WC	12.5	7.7	4.8	60.0	2.1	45.6	0.3	53.9
Trunk and Branch 100’ 80 psi Static	0.0	0.0	0.0	80.0	0.0	74.5	0.0	75.4
TF	2.9	0.4	2.5	80.0	2.6	68.7	0.3	75.1
TF+Lav	5.0	2.0	3.0	80.0	2.6	67.9	0.3	73.0
TF+WC	7.8	5.5	2.3	80.0	2.6	69.4	0.3	62.4
TF+Kit	5.0	1.7	3.3	80.0	2.6	68.5	0.3	75.0

Table A.1 – Simultaneous Flow Performance Data – 100' Maximum Length, 60 and 80 psi Source Pressure <i>(continued)</i>								
Fixture Flow	Total System Flow	Cold Supply Flow	Hot Supply Flow	Main Pressure	Test Fixture (Shower)			
					Hot Flow	Hot Pres.	Cold Flow	Cold Pres.
					gpm	psi	gpm	psi
TF+Sh2	6.0	1.8	4.1	80.0	2.6	67.9	0.3	74.8
TF+Sh2+Kit	7.9	2.9	5.0	80.0	2.5	66.3	0.3	74.3
TF+Sh2+Kit+Lav	9.9	4.8	5.2	80.0	2.5	65.2	0.3	71.3
TF+Sh2+Kit+Lav+WC	14.4	8.3	6.1	80.0	2.4	61.6	0.3	60.9
Zone 100' 80 psi Static	0.0	0.0	0.0	80.0	0.0	74.6	0.0	75.4
TF	2.9	0.5	2.4	80.0	2.6	68.7	0.3	75.1
TF+Lav	5.0	1.9	3.1	80.0	2.5	67.3	0.3	74.0
TF+WC	7.8	5.5	2.3	80.0	2.6	68.9	0.3	67.6
TF+Kit	5.0	1.7	3.2	80.0	2.6	68.2	0.3	74.8
TF+Sh2	6.0	1.8	4.1	80.0	2.5	67.2	0.3	74.8
TF+Sh2+Kit	7.9	34.1	4.8	80.0	2.5	65.9	0.3	74.5
TF+Sh2+Kit+Lav	9.9	4.8	5.1	80.0	2.5	65.0	0.3	72.7
TF+Sh2+Kit+Lav+WC	14.4	8.6	5.8	80.0	2.5	63.0	0.3	65.0
Parallel 100' 80 psi Static	0.0	0.0	0.0	80.0	0.0	74.5	0.0	75.3
TF	2.9	0.4	2.5	80.0	2.5	63.6	0.3	75.0
TF+Lav	5.0	1.7	3.3	80.0	2.5	63.3	0.3	74.8
TF+WC	7.8	5.3	2.6	80.0	2.5	64.4	0.3	74.6
TF+Kit	5.0	1.7	3.3	80.0	2.5	63.4	0.3	74.8
TF+Sh2	6.0	1.7	4.2	80.0	2.5	62.6	0.3	74.8
TF+Sh2+Kit	7.9	3.0	4.9	80.0	2.4	62.0	0.3	74.7
TF+Sh2+Kit+Lav	9.9	4.5	5.4	80.0	2.4	61.5	0.3	74.5
TF+Sh2+Kit+Lav+WC	14.4	8.9	5.5	80.0	2.4	62.0	0.3	73.8

TF = Test Shower Fixture, 15' elevation; **Lav** = Lavatory, both valves open, 15' elevation
WC = Water Closet, tank type, 15' elevation; **Kit** = Kitchen, mid-position, 4' elevation
Sh2 = 2nd Shower, full open valve, 5' elevation

**Table A.2 – Simultaneous Flow Performance Data –
60’ Maximum Length, 60 and 80 psi Source Pressure**

Fixture Flow	Total System Flow	Cold Supply Flow	Hot Supply Flow	Main Pressure	Test Fixture (Shower)			
					Hot Flow	Hot Pres.	Cold Flow	Cold Pres.
					gpm	psi	gpm	psi
Trunk and Branch 60’ 60 psi Static	0.0	0.0	0.0	60.0	0.0	54.2	0.0	55.1
TF	2.5	0.5	2.1	60.0	2.2	50.8	0.3	54.9
TF+Lav	4.3	1.8	2.5	60.0	2.2	49.9	0.3	53.7
TF+WC	6.8	4.7	2.1	60.0	2.2	50.8	0.2	46.5
TF+Kit	4.3	1.4	3.0	60.0	2.2	49.9	0.3	48.6
TF+Sh2	5.2	1.6	3.5	60.0	2.2	48.7	0.3	54.7
TF+Sh2+Kit	6.9	2.7	4.2	60.0	2.1	48.0	0.3	54.5
TF+Sh2+Kit+Lav	8.6	4.2	4.4	60.0	2.1	47.7	0.3	52.4
TF+Sh2+Kit+Lav+WC	12.5	7.3	5.2	60.0	2.1	46.0	0.2	46.5
Zone 60’ 60 psi Static	0.0	0.0	0.0	60.0	0.0	54.0	0.0	55.2
TF	2.5	0.5	2.0	60.0	2.2	50.6	0.3	55.0
TF+Lav	4.3	1.7	2.6	60.0	2.2	50.1	0.3	54.5
TF+WC	6.8	4.7	2.1	60.0	2.2	50.9	0.3	51.7
TF+Kit	4.3	1.7	2.7	60.0	2.2	50.2	0.3	54.8
TF+Sh2	5.2	1.6	3.6	60.0	2.2	49.2	0.3	54.7
TF+Sh2+Kit	6.9	2.7	4.2	60.0	2.2	48.5	0.3	54.4
TF+Sh2+Kit+Lav	8.6	4.1	4.5	60.0	2.1	48.0	0.3	53.5
TF+Sh2+Kit+Lav+WC	12.5	7.5	5.0	60.0	2.1	47.4	0.2	49.7
Parallel 60’ 60 psi Static	0.0	0.0	0.0	60.0	0.0	27.6	0.0	28.5
TF	2.5	0.5	2.0	60.0	2.2	48.8	0.3	54.9
TF+Lav	4.3	1.5	2.8	60.0	2.2	48.6	0.3	54.8
TF+WC	6.8	4.8	2.0	60.0	2.2	49.3	0.3	54.6

Table A.2 – Simultaneous Flow Performance Data – 60' Maximum Length, 60 and 80 psi Source Pressure <i>(continued)</i>								
Fixture Flow	Total System Flow	Cold Supply Flow	Hot Supply Flow	Main Pressure	Test Fixture (Shower)			
					Hot Flow	Hot Pres.	Cold Flow	Cold Pres.
					gpm	psi	gpm	psi
TF+Kit	4.3	1.7	2.7	60.0	2.2	48.5	0.3	54.8
TF+Sh2	5.2	1.7	3.5	60.0	2.1	47.8	0.3	54.8
TF+Sh2+Kit	6.9	2.7	4.2	60.0	2.1	47.3	0.3	54.6
TF+Sh2+Kit+Lav	8.6	4.0	4.6	60.0	2.1	46.9	0.3	54.5
TF+Sh2+Kit+Lav+WC	12.5	7.8	4.6	60.0	2.1	47.5	0.3	54.0
Trunk and Branch 60' 80 psi Static	0.0	0.0	0.0	80.0	0.0	74.6	0.0	75.4
TF	2.9	0.4	2.5	80.0	2.6	69.9	0.3	75.2
TF+Lav	5.0	2.0	3.0	80.0	2.6	68.9	0.3	73.8
TF+WC	7.8	5.5	2.3	80.0	2.6	70.2	0.3	66.4
TF+Kit	5.0	1.7	3.3	80.0	2.6	69.4	0.3	75.0
TF+Sh2	6.0	1.8	4.2	80.0	2.6	68.2	0.3	75.1
TF+Sh2+Kit	7.9	2.9	5.0	80.0	2.5	66.9	0.3	74.7
TF+Sh2+Kit+Lav	9.9	4.7	5.2	80.0	2.5	66.1	0.3	72.1
TF+Sh2+Kit+Lav+WC	14.4	8.4	6.0	80.0	2.5	63.4	0.3	63.6
Zone 60' 80 psi Static	0.0	0.0	0.0	80.0	0.0	74.5	0.0	75.3
TF	2.9	0.5	2.4	80.0	2.6	70.2	0.3	75.1
TF+Lav	5.0	1.8	3.1	80.0	2.6	69.0	0.3	74.4
TF+WC	7.8	5.6	2.2	80.0	2.6	70.2	0.3	69.9
TF+Kit	5.0	1.8	3.2	80.0	2.6	69.4	0.3	74.9
TF+Sh2	6.0	1.9	4.1	80.0	2.6	68.4	0.3	74.8
TF+Sh2+Kit	7.9	2.9	5.0	80.0	2.5	66.7	0.3	74.5
TF+Sh2+Kit+Lav	9.9	4.6	5.3	80.0	2.5	66.0	0.3	73.4
TF+Sh2+Kit+Lav+WC	14.4	8.7	5.7	80.0	2.5	64.5	0.3	67.7

**Table A.2 – Simultaneous Flow Performance Data –
60’ Maximum Length, 60 and 80 psi Source Pressure** *(continued)*

Fixture Flow	Total System Flow	Cold Supply Flow	Hot Supply Flow	Main Pressure	Test Fixture (Shower)			
					Hot Flow	Hot Pres.	Cold Flow	Cold Pres.
					gpm	psi	gpm	psi
Parallel 60’ 80 psi Static	0.0	0.0	0.0	80.0	0.0	74.5	0.0	75.3
TF	2.9	0.5	2.4	80.0	2.5	66.9	0.3	75.1
TF+Lav	5.0	1.6	3.4	80.0	2.5	66.3	0.3	75.0
TF+WC	7.8	5.4	2.5	80.0	2.5	67.3	0.3	74.7
TF+Kit	5.0	1.6	3.4	80.0	2.5	66.4	0.3	74.9
TF+Sh2	6.0	1.8	4.2	80.0	2.5	65.8	0.3	75.0
TF+Sh2+Kit	7.9	2.9	5.0	80.0	2.5	64.8	0.3	74.8
TF+Sh2+Kit+Lav	9.9	4.5	5.5	80.0	2.5	63.8	0.3	74.6
TF+Sh2+Kit+Lav+WC	14.4	9.0	5.4	80.0	2.5	64.2	0.3	73.9

TF = Test Shower Fixture, 15’ elevation; **Lav** = Lavatory, both valves open, 15’ elevation
WC = Water Closet, tank type, 15’ elevation; **Kit** = Kitchen, mid-position, 4’ elevation
Sh2 = 2nd Shower, full open valve, 5’ elevation

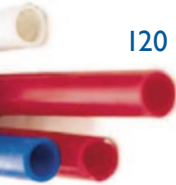

Appendix

INSTALLATION CHECKLIST

DESIGN

- Consult Local Codes
- Select Pipe and Joining System
- Design Piping System
 - Optimize Home Layout
 - Select Appropriate System
 - Plan Piping Routing
 - Plan Manifold and Valve Locations
- Estimate Material and Order

TRAINING

- Train piping installers on installation techniques and fittings
- Order or rent fitting tools

INSTALLATION

- Receive material and store as recommended by manufacturer
- Review piping plan with installers
- Ensure tools are calibrated/maintained
- Install per plan and manufacturer recommendations
- Pressure test per manufacturer recommendations and code requirements

FOLLOW UP

- Instruct homeowner on location and operation of manifold valves (if applicable)



Appendix B – INSTALLATION CHECKLIST

Appendix

RESOURCES

Articles and Reports

1. **Automated Builder Magazine, “PEX Pipe Gains Popularity for Practical Purposes.”** April 2005, page 40. This article presents the multitude of advantages to using PEX plumbing water supply systems in residential construction, and discusses the standards and certifications required for PEX pipe and fittings. One home builder’s experience with PEX and a manifold system is described.
2. **Couch, Toro, Oliphant and Vibien, *Chlorine Resistance Testing of UV Exposed Pipe*,** Jana Laboratories, Ontario, Canada, 2002. Chlorine Resistance (CR) testing is used to determine the impact of accelerated UV exposure on the oxidative resistance of cross-linked polyethylene (PEX) pipe. Following accelerated UV exposure, samples were tested to failure under accelerated test conditions to simulate chlorinated potable water. For the particular material examined, it was demonstrated that excellent retention of oxidative stability was achieved when suitable UV protection was employed.
3. **Kempton, William, “Residential Hot Water: A Behaviorally-Driven System,”** *Energy*, Volume 13, Number 1, January 1988, pages 107-114. This article reports on the results of monitoring the hot water use in seven homes over 7-18 months. The study shows the wide variation in hot water use among the different project participants. For instance, water consumption ranged from 44.5 liters per day per person to 126.4 liters per day per person. Bathing comprised the largest single water use in all homes but duration and volume varied significantly. The study points to the potential for water and energy savings through modification of behavior but also notes that habits related to hot water usage have deep roots in personal, social, and cultural values. The study also found that most of the participants had misperceptions related to the duration and amount of their water usage and did not have a firm understanding of the costs of hot water.

4. **Korman, Thomas M. et al, *Knowledge and Reasoning for MEP Coordination, Journal of Construction and Engineering Management*, Volume 129 Number 6, November-December 2003, pp. 627-634.** “Currently, designers and constructors use tailored CAD systems to design and fabricate MEP systems, but no knowledge-based computer technology exists to assist in the multidiscipline MEP coordination effort. The paper describes results from a research project to capture knowledge related to design criteria, construction, operations, and maintenance of MEP systems and apply this knowledge in a computer tool that can assist designers and builders in resolving coordination problems for multiple MEP systems.” This work might provide background information relevant to developing a knowledge-based design tool for residential plumbing distribution systems.
5. **NSF International, *Frequently Asked Questions on Health Effects of PEX Tubing*.** This article explains who NSF International is, provides information on NSF Listed Products for potable water applications, and describes applicable NSF/ANSI standards for testing and evaluation of potable plumbing.
6. **Okajima, Toshio, *Computerized Mechanical and Plumbing Design, Actual Specifying Engineer*, Volume 33 Number 6, June 1975, pp. 78-83.** “Many mechanical and plumbing systems designs are based on the engineer’s past experience or educated guesses. The author tells how one firm developed a computer program for plumbing and heating, ventilating, and air conditioning design.”
7. **Orloski, M.J. and Wyly, R.S., *Performance Criteria and Plumbing System Design*, National Engineering Lab, Washington, D.C., 1978.** “An overview is presented indicating how the performance approach to plumbing system design can be used to extend traditional methods to innovative systems. ...Some of the mathematical models now used for system design and pipe sizing in plumbing codes are reviewed in the context of performance-oriented research. ... Conceivably the re-examination by plumbing designers of traditional design criteria against measured user needs could be beneficially extended to other areas of plumbing design such as water distribution, storm drainage, and plumbing fixtures. Beyond this, it has been recognized that uniform guidelines for evaluation of innovative systems, based on research findings, are essential for wide acceptance of performance methods, particularly by the regulatory community.
8. **Rubeiz, Camille, “Flexing Your PEX: Plumbing the Possibilities of Cross-linked Polyethylene Pipes,” *Modern Materials*, Vol. 2, No. 2, November 2004, pages 5-8.** Properties of PEX pipe are described, as well as benefits of using PEX for potable water supply plumbing systems. Parallel piping and central manifold system installations are discussed. Real and misconceived limitations are also presented. In addition, other applications for PEX pipe systems, such as snow and ice melt and turf conditioning are mentioned.
9. **Rubeiz, Camille & Ball, Michael, “Warming Up to PEX Pipe Radiant Heating Systems,” *Modern Materials*, Vol. 2 No. 1, May 2004, pages 14-18.** The article describes how radiant heating works, and compares the radiant heat distribution to traditional baseboard or forced air systems. There is a general description of the three methods of cross-linking polyethylene to form PEX piping (radiation, peroxide,

and silane processes). Applicable ASTM and CSA standard specifications for testing of PEX pipe and fittings are listed. Finally, the article briefly discusses the installation of PEX radiant heating systems in new residential construction or remodeling projects.

10. **Steele, Alfred, “Plumbing Design Has Major Impact on Energy Consumption,”** *Specifying Engineer*, Volume 45, Number 6, June 1981, pages 80-83. The paper discusses the potential energy savings that could result from low-flow fixtures, pipe insulation, and water heater temperature settings. The author emphasizes that significant water savings and therefore, energy savings as well could be achieved with no inconvenience to the end-user. It was not until 1994 that the first low-flow fixtures were introduced in the United States after being federally mandated.
11. **Stewart, William E. et al, *Evaluation of Service Hot Water Distribution system Losses in Residential and Commercial Installations: Part 1 – Field/Laboratory Experiments and Simulation Model and Part 2 – Simulations and Design Practices*, ASHRAE Transactions, Volume 105, 1999.** The papers describe a numerical model developed to estimate the heat loss or gain from insulated and uninsulated, copper and steel hot water pipes. The authors contend that the simulation model is a more reliable and consistent method of estimating such losses due to the difficulty of accurately measuring small temperature differences in field and laboratory experiments. The results of the simulation model correlate closely with previously published data, specifically 1997 ASHRAE Handbook – Fundamentals and 1995 ASHRAE Handbook – HVAC Applications. The simulation results showed more than a 50 percent decrease in heat loss in hot water piping that was insulated within approximately three feet of the water heater and that increasing the length of pipe insulated does not significantly decrease heat loss further.
12. **Tao, William & Associates, “Plumbing System Design,”** *Heating, Piping, & Air Conditioning*, Volume 59 Number 3, March 1987, pp. 101-114. This article outlines the fundamental criteria to be considered in the design of a building plumbing system. These criteria include load calculations, system sizing, and special design applications. A procedure for plumbing system design is also introduced that may serve as a comprehensive basis for developing computer aided design programs.
13. **Vibien, Couch, Oliphant et al, *Assessing Material Performance in Chlorinated Potable Water Applications*,** Jana Laboratories, Ontario, Canada. In this study, the nature of the failure mechanism of cross-linked polyethylene (PEX) pipe material exposed in the laboratory to chlorinated potable water was examined. Based on this study, the PEX pipe material appears to have good resistance to chlorinated potable water.
14. **Wendt, R.L., Evelyn Baskin, David Durfee, *Evaluation of Residential Hot Water Distribution Systems by Numeric Simulation*,** Buildings Technology Center, Oak Ridge National Laboratory for the California Energy Commission, Oak Ridge, TN, 2004. This study simulated and compared the energy and water performance, economics, and barriers to use of various domestic hot water distribution systems in California homes. Variation in systems included trunk and branch, manifold systems, copper pipe, CPVC pipe, PEX piping, insulated and uninsulated pipe, attic location, slab

location, demand recirculation, and continuous recirculation. Using a computer model, LabView, the following results were found for a clustered hot water usage pattern:

- a. Demand recirculation systems, whether piping was copper or CPVC, wasted the least water and the least energy.
- b. Whether copper or CPVC piping was used, the system with a centrally located water heater was second with respect to the least amount of energy wasted. However, almost twice as much water was wasted in comparison to the recirculation systems even though the water heater was centrally located.
- c. In both groups, the CPVC systems were slightly better energy performers than their copper counterparts – about 4 to 14 percent better.
- d. The parallel pipe configurations using PEX tubing wasted about 3 percent more energy than uninsulated copper pipe in an attic installation, but wasted 60 percent less energy than uninsulated copper installed in a slab. Insulating the sub-slab copper pipe brought its energy performance inline with the PEX system. With respect to water waste, the parallel system (attic installation) performed similarly to copper pipe installed in an attic.
- e. Sub-slab installation without insulation compromised the energy and water performance of all the systems. However, the parallel system using PEX pipe suffered the least – an approximate 30 percent drop in performance compared to a fourfold decrease for the copper and CPVC systems.
- f. Construction costs for the parallel system using PEX tubing were slightly lower than the trunk and branch system using copper, but higher than the CPVC systems.

While the study indicates that usage patterns have the most significant effect upon energy usage and water consumption in residential situations, it also postulates that “parallel pipe distribution systems may offer an attractive alternative for some house designs and distribution system layouts.” The modeling showed very little difference in energy and water performance when clustered use was assumed but indicated that parallel systems outperform conventional trunk and branch systems when cold starts are typical.

15. **Wiehagen, J. and Sikora, J. (March 2003). *Performance Comparison of Residential Hot Water Systems***, work performed by NAHB Research Center, Inc. for NREL. Using data from two research sites in Ohio and from weekly laboratory experimental data, a simulation model was developed to estimate annual energy consumption for several types of water-heating systems. Using the Transient Energy System Simulation Tool, TRNSYS, three types of systems were analyzed under high-usage (average 76 gallons per day) and low-usage conditions (average 28 gallons per day). The systems were 1) a standard electric storage tank water heater with a copper tree-configuration distribution system, 2) a central tankless water heater with a polyethylene (PEX) piping parallel distribution system, and 3) multiple point-of-use water heaters with a copper tree-type distribution system. The simulations showed a 12 percent increase in overall system efficiency for the tankless water heater with the PEX parallel piping system compared to the storage heater with the copper tree system under high usage conditions. For the low-use home, there was a 26 percent

increase in efficiency for the same system. The analysis also indicated energy savings for the PEX parallel piping configuration whether the water heating equipment was a conventional tank or a tankless system – 6 percent savings for the high-use home and 13 percent savings for the low-use home. Analysis of the tree-type system with multiple point-of-use heaters also showed improved energy performance in comparison to a similar treed distribution system with a storage tank water heater – a 50 percent reduction in energy consumption for the low-use condition and 28 percent reduction for the high-use home. In addition to the energy savings, an economic analysis showed a positive annual cash flow for the parallel distribution systems whether a tank or tankless heater was used compared to the standard tank/tree system. The analysis included estimates of installed cost, financing costs, and electricity costs.

16. **Wiehagen, J. and Sikora, J. (April, 2002). *Domestic Hot Water System Modeling for the Design of Energy Efficient Systems***, work performed by NAHB Research Center, Inc. for NREL. Using data obtained from actual home sites, the researchers developed a computer simulation model to analyze typical residential plumbing systems. The evaluation compared demand water heating equipment in conjunction with various piping configurations to a standard tank heater with a tree delivery system. High- and low-usage patterns were considered. Maximum energy savings resulted from using a combination of a centrally located demand water heater with a parallel piping system. Annual energy savings were 17 percent for the high consumption home and 35 percent for the low use home. The demand system did show some hot water temperature degradation during periods of high flow rates.
17. **Wyly, R.S. et al, (May 1975). “Review of Standards and Other Information on Thermoplastic Piping in Residential Plumbing.”** Sponsored by the U.S. Department of Housing and Urban Development, Washington, D.C. “The paper is a review of existing information on the physical characteristics of thermoplastic piping that are of particular interest in considering its potential for use in residential above-ground plumbing. The presentation is oriented to considerations of adequacy of functional performance of plumbing systems from the user’s/owner’s viewpoint in contrast with the typical product-specifications oriented format reflected in current standards. Not only are the physical characteristics emphasized that relate most directly to the determination of functional performance of installed systems, but the importance of design and installation detail in the context is discussed. In conclusion, this review indicates the need for better use of existing knowledge as well as for some research and test development work particularly in the areas of thermal properties, response to building fires, and resistance to water hammer.”

Manufacturers' Information

1. **NIBCO, Inc. (2011) *NIBCO® PEX Piping Systems Installation Manual***, Elkhart IN. The manual provides specific instructions to properly install NIBCO PEX plumbing systems and accessories. Also included are correct methods for making crimp, clamp, and sleeve connections with both metal and poly insert fittings. Definitions, tables, and warranty are included in the document as well.
2. **Uponor, Inc. (2011) *Uponor Professional Plumbing Installation Guide***, Apple Valley, MN. Uponor's installation guide is published for building officials, plumbing professionals and contractors interested in Uponor professional plumbing systems. This manual describes general installation recommendations that use Uponor AquaPEX tubing products. Local code requirements should be followed.
3. **Viega LLC, *PEX Water Systems Installation Manual (2012)***, Bedford, MA. This manual provides detailed instructions for the installation of ViegaPEX, FostaPEX tubing and the ManaBloc parallel water distribution system. Included are design and layout strategies and pressure drop information that could be used to develop more specific design tools. Guidance given for parallel water distribution systems includes:
 - Typical supply line size per number of bathrooms;
 - Typical distribution line size per fixture flow requirement;
 - Use of multiple manifolds when the home is large or there are a large number of fixtures.
4. **Zurn, (2012) *Zurn PEX Plumbing Guide***, Zurn Industries, Inc., Erie, PA. The Zurn Guide offers similar installation instructions to the other manufacturers. Each manufacturer recommends their specific crimp tool and gauge. In addition to guidance regarding thermal expansion, protection from damage, pressure drop, and flow rate, the Zurn manual also discusses sizing and locating manifolds for parallel piping distribution systems. While deferring to local code requirements, Zurn does recommend using 3/8-inch tubing for hot water lines whenever possible to reduce wait time, stating that 3/8-inch tubing is usually adequate for most sink, lavatory, and shower fixtures unless the distance is greater than 80 feet.

Plastics Pipe Institute (PPI) Technical Publications

1. **TN-17 (2013). “Crosslinked Polyethylene (PEX) Pipe and Tubing.”** This technical note provides general information on cross-linked polyethylene (PEX), such as: “What is PEX?” and “How does PEX improve properties of PE?” Three methods of cross-linking polyethylene to form PEX, qualification standards, and certification requirement are presented. Finally, several applications for the use of PEX piping, and advantages of PEX pipe systems are listed.
2. **TN-26 (2005). “Erosion Study on Brass Insert Fittings Used in PEX Piping Systems.”** The objective of this test program was to subject different brass insert fittings and different pipe diameters for PEX plumbing systems to flow rates that represented the maximums that could occur if a plumbing system was sized according to the 2000 Uniform Plumbing Code. Enough chlorinated water flowed through the pipe and fittings equivalent to 40 years of service in a typical single family residence. None of the brass fittings failed during the test. Weight losses were less than 3 percent for all fittings. A test procedure is appended to this Technical Note.
3. **TN-31 (2010). “Differences between PEX and PB Piping Systems for Potable Water Applications.”** Several features and properties of PEX pipe are presented to differentiate between PEX and polybutylene (PB) systems. For instance, PEX is a crosslinked material, PEX pipes have 22% greater wall thickness, PEX pipes are tested to prove chlorine resistance, and PEX piping systems do not use polyacetal fittings.”
4. **TN-32 (2010). “UV Labeling Guidelines for PEX Pipes.”** These guidelines present recommendations for exposure and storage of PEX piping, and an example of a cautionary label to be applied to packaging to ensure that PEX is not over exposed to sunlight (UV radiation).
5. **TN-39 (2013). “Recommended Practices Regarding Application of Pesticides and Termiticides near PEX Pipes.”** This Technical Note describes recommendations for correct installation of PEX water pipes for service line applications as well as hot- and cold-water distribution use. These recommendations are intended for the installing plumber, and will help to prevent misapplication of liquid pesticides/termiticides around PEX pipes.
6. **National Association of Home Builders (2008). “Fixture Flow Rate Comparison Cross-Linked Polyethylene (PEX) Piping and Copper Tubing.”** This study was performed by NAHB-RC at the request of PPI to compare the volumetric flow rates of copper systems versus PEX systems, and the ability of each system to meet fixture demand requirements.
7. **PPI Statement A (2013). “Relative Oxidative Aggressiveness of Chloramines and Free Chlorine Disinfectants Used in Treated Potable Water on Cross-linked Polyethylene (PEX) Pipe.”** This PPI statement examines the relative oxidative aggressiveness of the common potable water disinfectants free chlorine and chloramines on crosslinked polyethylene (PEX) pipes.

8. **PPI Statement Y (2008). “Taste and Odor Statement.”** This PPI statement documents the history and requirements for the taste and odor and safety of plastic water pipes in North America including the mandatory test method/requirement in use in North America is the standard NSF/ANSI 61: Drinking Water System Components – Health Effects.
9. **AWWA recently published the 263 Committee Report: “Design and Installation of Crosslinked Polyethylene (PEX) Pipe in Accordance with AWWA C904.”** This committee report has been issued to provide basic guidance and references on the design and installation of PEX piping manufactured in accordance with ANSI/AWWA C904, and includes information about temperature/pressure capabilities, flexibility, pressure surge dissipation, freeze-break resistance, chlorine resistance, corrosion resistance, chemical resistance, erosion, tuberculation and design.
10. **PPFA (2011). “PEER-REVIEWED LIFE CYCLE INVENTORY FOR THE PRODUCTION AND USE OF INSTALLED RESIDENTIAL PIPING SYSTEMS FOR THREE HOUSE LAYOUTS.” Submitted to: Plastic Piping Education Foundation By: Franklin Associates, A Division of ERG.** The purpose of this study was to determine the baseline energy consumption and environmental releases associated with the production and use of residential pipe systems for three house layouts.
11. **TR-XX. “R-Value of PEX.”** This report conveys the results of a test program to determine the R-Value of PEX (thermal conductivity). Samples of PEX and PERT were tested. This document has not received a final TR designation as of the printing of this guide.



GLOSSARY

ASTM: American Society for Testing and Materials

Corrosion: deterioration in metals caused by oxidation or chemical action

Crosslinked polyethylene: a polyethylene material which has undergone a change in molecular structure using a chemical or a physical process whereby the polymer chains are chemically linked. Crosslinking of polyethylene into PEX for pipes results in improved properties such as elevated temperature strength and performance, chemical resistance, and resistance to slow crack growth.

Elasticity: a measure of material stiffness or the ability of the material to stretch or deform temporarily under a load

Fitting: a device or connection that allows the PEX pipe to change direction or size, such as a tee, elbow, or coupling

Fixture: a device or appliance at the end of a water supply distribution pipe line. Example: lavatory, water closet, tub/shower, dishwasher

IAPMO: International Association of Plumbing and Mechanical Officials

ICC: International Code Council

IPC: International Plumbing Code

IRC: International Residential Code

Joint: the connection of the PEX pipe to a fitting, fixture, or manifold

Manifold: a device having a series of ports that are used to connect distribution lines for several fixtures

NSPC: National Standard Plumbing Code



Outlet: see fixture

Parallel: a plumbing design that utilizes a central manifold and distribution piping to each hot and cold water fixture

pH: a scale ranging from 0 to 14 that ranks how acidic or alkaline a liquid is; water with a pH below 7 is considered acidic and water with a pH above 7 is considered alkaline

PPFA: Plastic Pipe and Fittings Association

PPI: Plastics Pipe Institute

Scaling: process of mineral buildup on the interior of a pipe

Test fixture: the tub-shower unit farthest from the water source that was instrumented to measure flow rate, flowing pressure, and mixed water temperature in the lab tests

Thermoplastic: having the property of becoming soft when heated and hard when cooled

Thermoset: having the property of becoming permanently hard and rigid when heated or cured

Trunk and branch: a plumbing design that has a large main line that feeds smaller pipes to each fixture

Ultraviolet: high energy light waves found in sunlight that lead to the degradation of many plastics and materials (UV)

UPC: Uniform Plumbing Code

Wait time: the time it takes for hot water to be delivered to the Test Fixture; delivery time

Water hammer: a banging noise heard in a water pipe following an abrupt alteration of the flow with resultant pressure surges

Zone: a plumbing system that uses trunk lines from the water source to small manifolds at grouped fixtures, such as a bathroom; can be flow-through or closed end

