



**Home Innovation**  
RESEARCH LABS™

# EXTENDED PLATE & BEAM WALL SYSTEM

## Summary of Initial Assessment

*Prepared For*

**NYSERDA**

**Greg Pedrick, C.E.M.**

**Project Manager, Buildings R&D**

**New York State Energy Research &**

**Development Authority**

**17 Columbia Circle Albany, NY 12203**

**Agreement #: 32042:**

**Purchase Order #: ERDA1-0000037212**

Report No. 3353-006\_08292014

**Disclaimer**

Neither Home Innovation Research Labs, Inc., nor any person acting on its behalf, makes any warranty, expressed or implied, with respect to the use of any information, apparatus, method, or process disclosed in this publication or that such use may not infringe privately owned rights, or assumes any liabilities with respect to the use of, or for damages resulting from the use of, any information, apparatus, method, or process disclosed in this publication, or is responsible for statements made or opinions expressed by individual authors.

# TABLE OF CONTENTS

## Contents

|  |    |
|--|----|
| Introduction .....   | 1  |
| EP&B Construction Details.....   | 2  |
| EP&B Scope of Work (Framing) .....   | 4  |
| Cost Comparison.....   | 5  |
| Results of Exploratory Structural Testing.....                                   | 8  |
| Building Industry Stakeholder Review .....                                       | 13 |
| Example Building Code Prescriptive Requirements for the EP&B Wall System .....   | 19 |
| Summary and Next Steps.....  | 22 |
| Appendix A. EP&B Example Details.....  | 23 |
| Appendix B. EP&B Framing Scope of Work.....                                      | 34 |
| Appendix C. EP&B Introduction Presentation Materials for Stakeholder Groups..... | 38 |



## Introduction

A new high performance wall system – Extended Plate and Beam (EP&B) – is currently under development and evaluation. Multiple approaches to higher R-value walls systems have been demonstrated since the 1970's. However, market penetration of these wall systems remains low, due in part to the added complexity and variations from standard details.

Any large-scale builder transition to a higher performing wall system will require construction details and methods that are based on common and accepted industry practices. This is understood based on the minimal diffusion of alternative wall systems such as Structural Insulated Panels (SIPs) or Insulated Concrete Forms (ICF) wall technologies that have a long history in the building industry. The transition time for builders to make significant changes to construction practices is known to extend over decades. The EP&B wall system was developed as an opportunity to bridge this long transition timeframe by maintaining industry accepted construction practices while employing wall design features that increase the thermal performance of the wall by over 50%.

The EP&B wall system design, originally developed at the Home Innovation Research Labs, incorporates standard 2x4 or advanced 2x6 wall framing but includes outside wall plates 2 inches larger than the stud framing (the inside member of the double top plate is the same size as the stud framing). Rigid foam insulation is installed in the space between the stud framing and the extended plates. Structural sheathing is placed over the foam and plates and attached through the foam to the studs and directly to the plates using a revised nailing pattern per the included details.

The EP&B wall system has undergone initial laboratory structural testing and is undergoing field testing for constructability. With support from the New York State Energy Research and Development Authority (NYSERDA), the EP&B wall system continues to undergo developmental improvements to validate the structural performance and enhance the constructability and usability of the wall system.

This report provides a compilation summary of a series of detailed reports on the EP&B wall system submitted to NYSERDA by Home Innovation Research Labs addressing the following topics:

- 1) EP&B Construction Details
- 2) EP&B Scope of Work
- 3) Cost Comparison with Other Wall Systems in the same R-value Range
- 4) Results of Exploratory Structural Testing
- 5) Stakeholder Assessment
- 6) Example Prescriptive Code Provisions

## EP&B Construction Details

An initial step in the assessment was to develop a set of EP&B construction example details and provide them to a stakeholder group for evaluation. Based on the evaluation a revised set of construction details was developed for both of the EP&B wall configurations. The example details are included for two (2) EP&B wall configurations:

1. 2x4 framing with 2x6 plates
2. 2x6 framing with 7.5 in. (ripped) plates

For each wall configuration, the set of details includes:

- Wall header options
- Rim header options
- Foundation rim
- Window framing
- Door framing
- Structural sheathing nailing pattern
- Outside corner framing and insulation options
- Outside corner structural sheathing options
- Inside corner framing options

Figure 1 shows a cross-section view of a 2x4 EP&B wall with 2x6 plates. Other details are included in Appendix A.

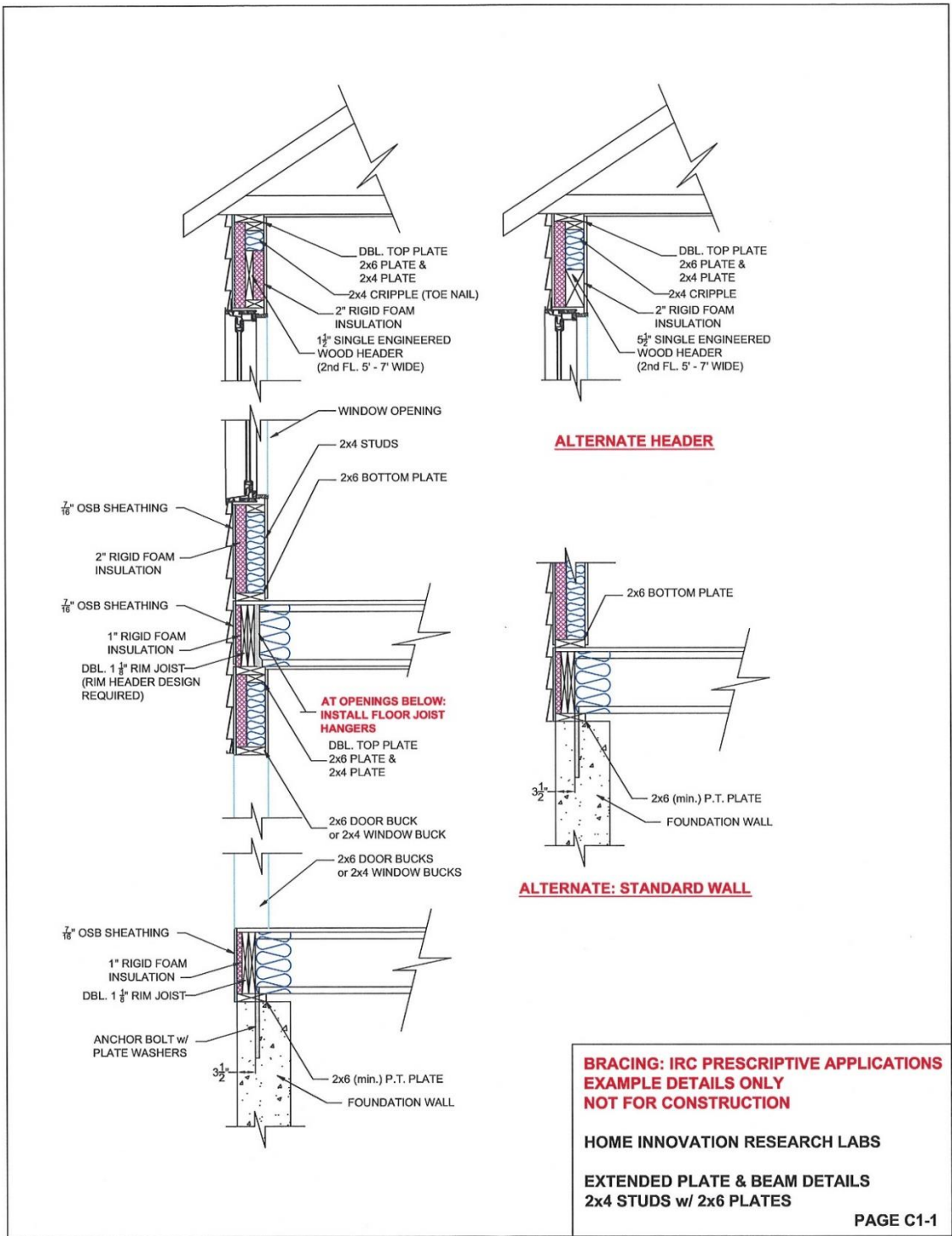

Figure 1. EP&B: Example Cross Section Detail

## **EP&B Scope of Work (Framing)**

An example Scope of Work was developed to support implementation of construction details. It is recommended that a Scope of Work is included with construction documentation and distributed to framing trades. The presented Scope of Work is limited to framing practices. Other trades that may be affected by the EP&B framing include those responsible for air sealing and cladding installation. Cavity insulation is installed in a manner consistent with the standard light frame construction.

The Scope of Work is attached in Appendix B. An outline of the Scope of Work includes the following sections:

- 1. Introduction**
- 2. Material List**
- 3. Field-Framing Guidelines**
  - 3.1. Sill plate and First Floor Construction**
  - 3.2. Wall construction**
  - 3.3. First Floor Openings**
  - 3.4. Rim Headers and Second Floor Construction**
  - 3.5. Top Floor Openings**
  - 3.6. Corner Details (Exterior Walls)**



## Cost Comparison

An important aspect of the assessment was to analyze the cost of the EP&B wall design in comparison with other high performance wall systems. A reference wall section size and configuration was developed for the analysis. The reference wall section included the supported rim in order to address all cost implications on analyzed systems. The wall section was 20 feet wide by 10 feet in height (9 feet wall and one foot rim) and included a 6-foot by 5-foot window (3050 twin) to capture the cost impact on framing and detailing of openings. The window opening represented 15 percent of the total wall area – a typical ratio for residential construction. Each wall included all components including interior and exterior finishes. Figure 2 shows the reference wall configuration.

Two types of claddings were analyzed: vinyl siding and fiber cement siding. These two cladding were selected for their difference in price and installation requirements. Nine wall types were analyzed with each cladding for a total of 18 (eighteen) unique wall assemblies. Table 1 summarizes the wall assemblies and estimated costs. Key variables between wall assemblies included framing (2x4 vs 2x6 vs double wall vs EP&B), stud spacing (16" vs 24" oc), framing at openings (standard vs rim header), XPS foam (no foam, 2" foam, 1"+3/4" foam), and other derivative details. For walls with 2 inches of exterior rigid foam insulation, furring strips are used for siding attachment. Where vinyl siding is attached to furring strips, a ½-inch rigid foam backer is installed between the furring strips to comply with wind rating requirements for a solid backer behind vinyl siding.

Costs were developed and represented at the national level from three primary sources:

- Home Innovation Research Labs' database<sup>1</sup> that was originally compiled in 2008 and has been updated and expanded over the following five years;
- R.S. Means Residential Cost Data 2014<sup>2</sup> (RSM 2014); and
- Websites for major national manufactures and retailers.

Where additional labor time was needed for specific tasks not directly addressed by standard cost guides, the labor rate from RSM 2014 was used. The reported costs contain overhead and profit (O&P) expected to be charged by trades and suppliers (i.e., builder's costs). No builder O&P has been added.

The costs are evaluated for the entire wall system in order to capture the interaction effects (e.g., impact of the header type on the number of supporting studs, impact of the cladding type of the backing material, etc). The system approach also allows for evaluating the cost impact of increasing the wall's R-value relative to the entire cost of the wall system.

---

<sup>1</sup> Economic Database in Support of ASHRAE 90.2 (Energy-Efficient Design of Low-Rise Residential Buildings), 1481 RP, Prepared for AHSRAE, Prepared by NAHB Research Center, Upper Marlboro, MD, December 2008.

<sup>2</sup> Published by Reed Construction Data (<http://rsmeans.reedconstructiondata.com/default.aspx>).

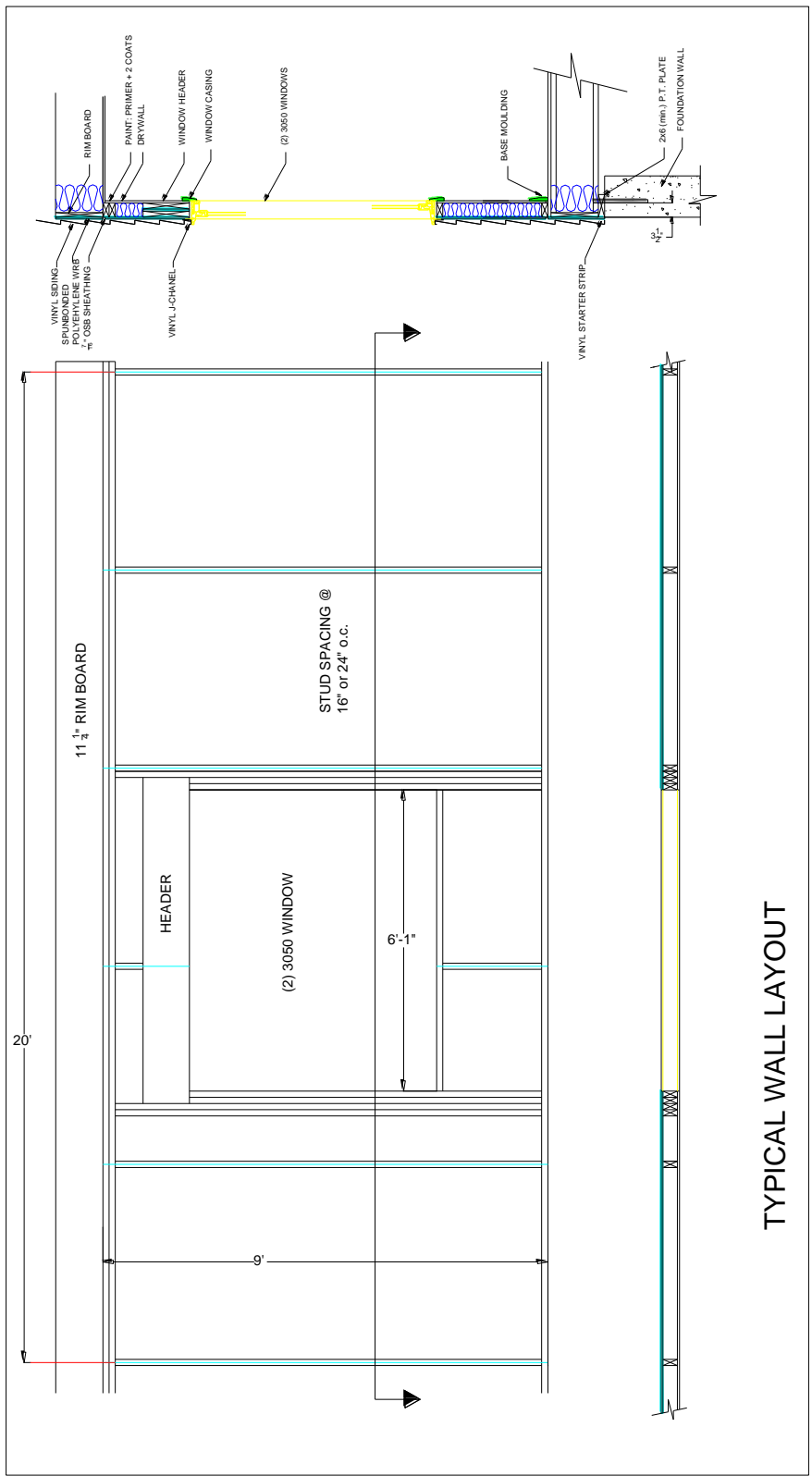

Figure 2. Reference Wall Layout

Table 1. Cost Summary

| Wall Type    |                         | Fig # | R-Value Nominal | Total Width | Total Cost | Cost/SF | Cost/SF increase | Cost per R value per SF |
|--------------|-------------------------|-------|-----------------|-------------|------------|---------|------------------|-------------------------|
| Vinyl Siding |                         |       |                 |             |            |         |                  |                         |
| 1VS          | 2x4 @ 16" o.c.          | 1     | 13              | 4.4         | \$3,499.48 | \$17.50 | n/a              | \$1.35                  |
| 2VS          | 2x6 @ 24" o.c.          | 2     | 20              | 6.4         | \$3,509.98 | \$17.55 | ref              | \$0.89                  |
| 3VS          | 2x6 @ 16" o.c.          | 3     | 20              | 6.4         | \$3,576.98 | \$17.88 | \$0.34           | \$0.90                  |
| 4VS          | Ext P&B 2x4/2x6         | 4     | 23              | 4.4         | \$3,935.18 | \$19.68 | \$2.13           | \$0.87                  |
| 5VS          | 2x4 w/2" +1/2" ext foam | 5     | 25              | 6.9         | \$4,305.02 | \$21.53 | \$3.98           | \$0.86                  |
| 6VS          | 2x6 w/2" +1/2" ext foam | 6     | 32              | 8.9         | \$4,435.72 | \$22.18 | \$4.63           | \$0.69                  |
| 7VS          | Ext P&B 2x6/2x8         | 7     | 29              | 6.4         | \$4,147.68 | \$20.74 | \$3.19           | \$0.73                  |
| 8VS          | Ext P&B 2x6/1.5x7.5     | 8     | 30              | 6.4         | \$4,043.38 | \$20.22 | \$2.67           | \$0.68                  |
| 9VS          | 2x4 dbl stud w/ 1" gap  | 9     | 29              | 8.9         | \$3,994.43 | \$19.97 | \$2.42           | \$0.69                  |

| Fiber Cement Siding <sup>A</sup> |                        | Fig # | R-Value Nominal | Total Width | Total Cost | Cost/SF | Cost/SF increase | Cost per R value per SF |
|----------------------------------|------------------------|-------|-----------------|-------------|------------|---------|------------------|-------------------------|
| 1FCS                             | 2x4 @ 16" o.c.         |       |                 |             |            |         |                  |                         |
| 2FCS                             | 2x6 @ 24" o.c.         | 3     | 20              | 6.4         | \$3,798.80 | \$18.99 | ref              | \$0.96                  |
| 3FCS                             | 2x6 @ 16" o.c.         | 2     | 20              | 6.4         | \$3,865.80 | \$19.33 | \$0.34           | \$0.98                  |
| 4FCS                             | Ext P&B 2x4/2x6        | 4     | 23              | 4.4         | \$4,224.00 | \$21.12 | \$2.13           | \$0.93                  |
| 5FCS                             | 2x4 w/2" ext foam      | 5     | 23              | 6.4         | \$4,333.64 | \$21.67 | \$2.67           | \$0.96                  |
| 6FCS                             | 2x6 w/2" ext foam      | 6     | 30              | 8.4         | \$4,464.34 | \$22.32 | \$3.33           | \$0.75                  |
| 7FCS                             | Ext P&B 2x6/2x8        | 7     | 29              | 6.4         | \$4,436.50 | \$22.18 | \$3.19           | \$0.78                  |
| 8FCS                             | Ext P&B 2x6/1.5x7.5    | 8     | 30              | 6.4         | \$4,332.20 | \$21.66 | \$2.67           | \$0.73                  |
| 9FCS                             | 2x4 dbl stud w/ 1" gap | 9     | 29              | 8.9         | \$4,283.25 | \$21.42 | \$2.42           | \$0.74                  |

Total Cost for 200 SF wall section, rim, 3050 dbl window, interior/exterior finishes

<sup>A</sup> Figures are in representation only. Wall sections still show vinyl details

Review of the results indicates that the cost of the EP&B system is comparable and in some cases lower than the cost of walls with the same R-value. The cost normalized by the R-value is also similar between walls types in the same R-value range. Therefore, the added benefit of the EP&B system do not come with an extra price and in some cases result in a moderate cost saving relative to comparable R-value alternatives.

## Results of Exploratory Structural Testing

The primary goal of this exploratory testing program was to understand the impact (if any) of the framing details and sheathing attachment on the structural load bearing capacity of the EP&B system.

One objective of this testing program was to evaluate the shear performance of an EP&B wall supported on 1) a rigid base, or 2) floor framing with a recessed rim joist. Another objective for the testing program was to evaluate the resistance of the wall/floor system subjected to gravity loads.

The test matrix is summarized in Table 2 including wall configuration details and a purpose statement for each test configuration. A total of three configurations were tested:

- Config. 1 (Shear Wall Test) – EP&B wall system with a 3-inch on center nailing pattern at the top and bottom extended plates;
- Config. 2 (Shear Wall Test) – EP&B wall system supported by floor framing with a single rim joist inset by 1 inch to accommodate foam insulation to the exterior of the rim; and
- Config. 3 (Vertical Test) – EP&B wall assembly consisting of two wall segments separated by floor framing with a double rim joist to the exterior edge of the extended plate.

Table 2. Test Matrix

| Conf. # | Test                     | Description   | Floor Framing   | Sheathing Fastener Schedule   | Purpose  |
|---------|--------------------------|---|---|---|--|
| 1-A     | Shear Wall (E 72-13a)    | EP&B Wall Supported on Rigid Base                         | n/a   | 4" x 0.131" nails at 3" o.c. on the top and bottom plates and 6" in the studs | Evaluate shear strength of EP&B wall with 3" o.c. nailing at plates for two nail diameters |
| 1-B     |                          |   |   | 4" x 0.148" nails at 3" o.c. on the top and bottom plates and 6" in the studs |  |
| 2       | Shear Wall (E 72-13a)    | EP&B Wall Supported by Floor Framing with Inset Rim Joist | 9-½" I-joists at 24" o.c. with (1) 1-½" rim joist inset | 4" x 0.148" nails at 3" o.c. on the top and bottom plates and 6" in the studs | Evaluate the impact of floor framing with inset rim joist (for exterior foam)              |
| 3       | Vertical Load (E 72-13a) | Two EP&B Walls Segments Separated by Floor Framing        | 9-½" I-joists at 16" o.c. with (2) x 1-½" rim joists    | 4" x 0.148" nails at 3" o.c. on the top and bottom plates and 6" in the studs | Evaluate vertical load path and compression strength of EB&B wall system through the floor |

Figure 3 through Figure 8 show specimen configurations and test setups.

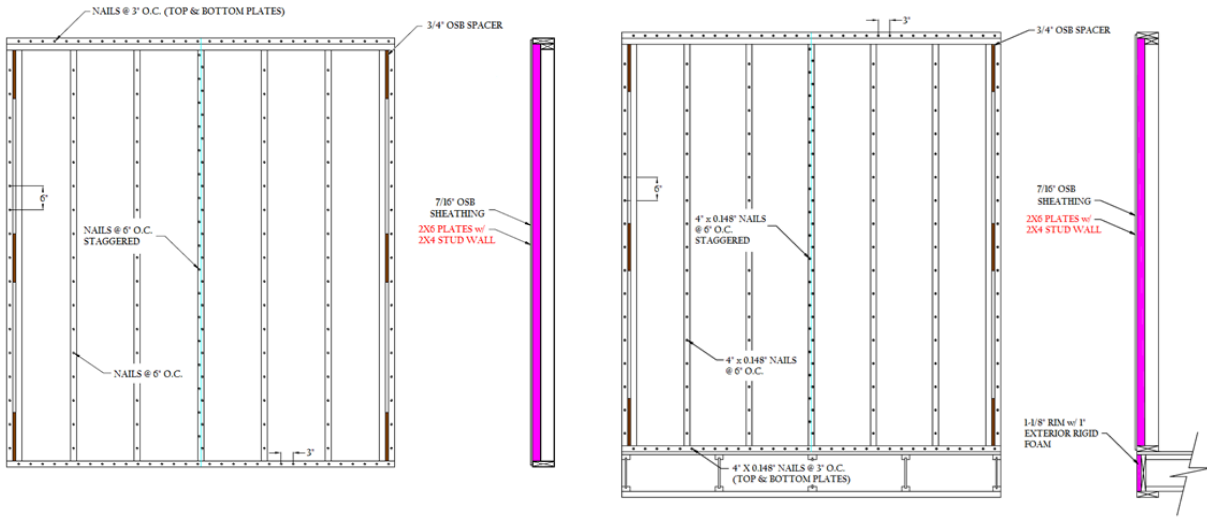

Configuration 1

Configuration 2

Figure 3. Shear Wall Test Configurations

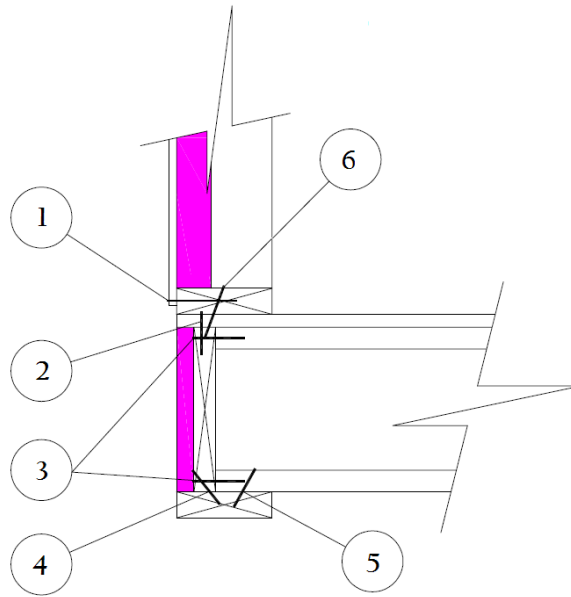

Figure 4. Configuration 2 Inset Rim Joist Detail

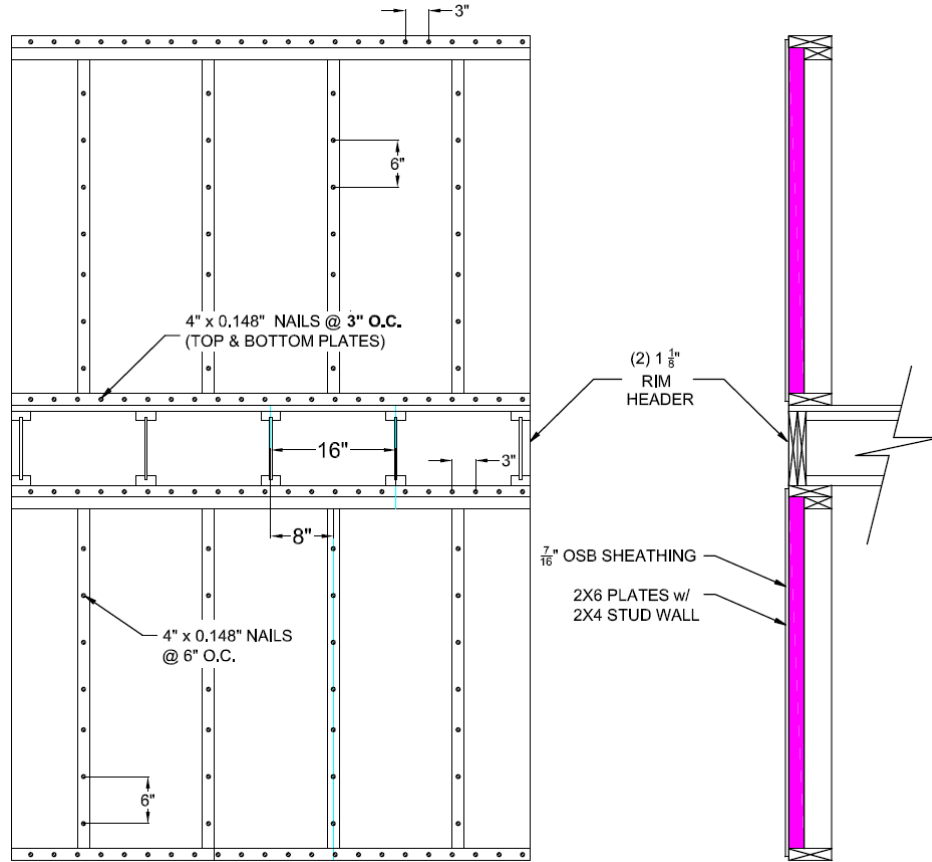
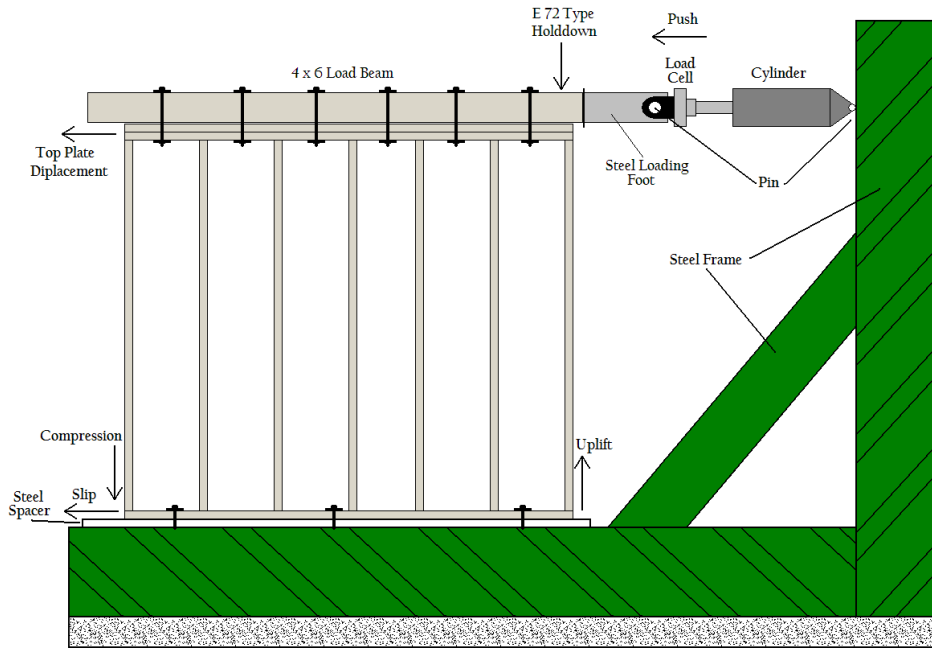

Figure 5. Configuration 3



Steel/Concrete Composite Section

Figure 6. Test Setup and Sensor Locations



Figure 7 Specimen in Test Setup with and without floor platform

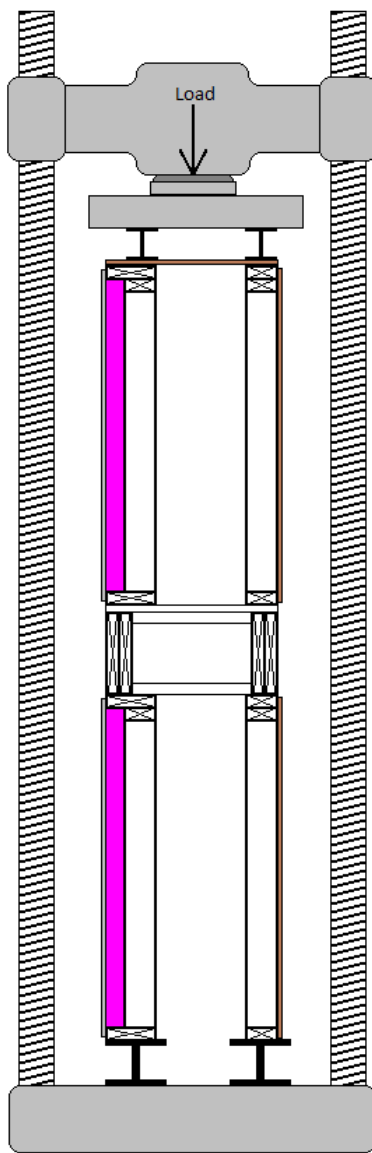

Figure 8. Configuration 3 Test Setup with Temporary Bracing

## EP&B Wall System Structural Testing Summary

The reported testing represents an exploratory phase of evaluation of the structural performance of the EP&B system. Results of the testing provide a basis for initial observations:

- The measured shear capacities are within the range of values for standard wood-frame walls used in typical low-rise residential construction in low-hazard areas (non-hurricane and non-seismic areas).
- The nail spacing increase from 2 inch on center to 3 inch on center can be offset by an increase in the nail diameter from 0.131 inch to 0.148 inch resulting in a similar shear capacity for both systems.
- When maintaining the 2 inch on center nail spacing, use of larger diameter nails of 0.148 inch showed an increased capacity of 18.2 percent when compared to the smaller 0.131 inch diameter nails.
- Shear wall tests performed with the specimen attached to a rigid base (Configuration 1) and with the specimen attached to a wood floor with an inset rim joint (Configuration 2) result in similar shear capacity. Therefore, inseting the rim by 1 inch to accommodate exterior foam insulation did not appear to have a significant effect on shear capacity.
- Vertical load testing indicates that the floor rim joist detail is capable of carrying story-to-story loads that exceed loads applicable for typical residential construction.



## Building Industry Stakeholder Review

A stakeholder group was convened with the purpose of reviewing design details for the EP&B wall system and independently assess the constructability of the wall system based on the initial proposed construction approach. The range of stakeholder backgrounds allowed for various perspectives on the EP&B wall construction and encouraged identification of specific details that would alter standard construction or fabrication processes.

The stakeholders were shown a power point presentation (Appendix C) outlining the EP&B wall system design as currently envisioned, structural testing to-date, and an initial field fabrication example. The participants asked to identify construction issues that might require changes to the initial wall design or that would require changes to typical construction practices. In order to accommodate all of the participants, two stakeholder meetings were held, one four-hour meeting held on March 5, 2014 at the NYSERDA offices in Albany (with one participant via webinar), and one hour and a quarter webinar meeting held March 21, 2014. The outcome of both stakeholder meetings is jointly reported below.

### EP&B Constructability Evaluation Based on Stakeholder Discussion

Various aspects of the EP&B wall system design and construction, including an overall discussion of higher R-value walls, highlighted the following summary points:

- 24 inches OC framing (applicable to 2x6 advanced framing option only) – issues identified include problems with gypsum installation on bowed framing members and subsequent framer resistance; non-alignment between wall framing at 24 inches OC and floor joist framing that is 16 inches or 19.2 inches OC. The alignment was seen as necessary for duct installation in the exterior walls.
- Increasing wall insulation – significant time was taken on the best methods and options to increase wall insulation. The discussion encompassed the barriers to adopting higher R-Value walls, approaches currently known to the participants such as spray polyurethane foam (SPF) and exterior foam sheathing are used less than 2x6 framing. Use of insulated vinyl siding was raised as one option for increasing the R-value of the wall. Use of SPF in modular construction was less common due to shipping concerns.
- Wall moisture performance – viewed as an important issue that must be considered in any higher R-value wall design and where more research is likely needed.
- Cavity dew point temperature – concerns arose on where the dew point temperature falls within the EP&B system and whether there was field data for both a 2x4 and 2x6 stud systems.
- Sheathing attachment – details of the EP&B sheathing attachment were presented and discussed at length. Structural shear nailing solely at the extended plates was viewed as a limitation in hurricane zones in the southern part of NY State. The use of non-standard nail guns to handle the 4 inches long nails in the field of the sheathing was seen as an extra cost that would need to be considered.

- Sheathing attachment – a close 2 inches on-center nailing pattern was viewed as a potential difficulty for framers and potentially a problem for the sheathing if the nail spacing ended up less than 2 inches on-center.
- Shear resistance – as one means to alleviate the reliance on the sheathing for shear resistance, one participant suggested using diagonal cross bracing located on the framing studs with 2-inch+ nails as alternative design.
- Sheathing attachment – sheathing installation is often overlapped to the rim/sill plate. The EP&B may need to accommodate the connection to the extended plate and include an overlap of the rim board.
- Rough opening – use of double sill/top rough window opening framing is common which conflicts with some advanced framing methodologies.
- Non-standard nail length – the suggestion was made to reduce the cost of use of 4 inches long nails; approach the nail gun supplier to retrofit a cartridge for larger 4-inch nails. Through the discussion it was resolved that this is an issue but if a builder is committed to this system calling for 4-inch nails goes to a supplier and asks for retrofit or manufacturers see a growing market for this system they will easily create a 4-inch nail gun that is acceptable. However, retooling for contractors can be expensive and must be accounted.
- Nailing accuracy – one potentially problematic detail of nailing through the sheathing and 2-inch foam to the stud is the difficulty for framers to reliably hit the studs.
- Nailing accuracy – one builder suggested using screws rather than nails, acknowledging this would slow installation down but had other advantages such as improved shear load capability.
- Design detail – use of the wall system in wall designs over 10 feet [e.g., an 18-foot wall in an atrium room] may be a limitation to use of the EP&B system [without a more complete set of design details].
- Design detail – use of the double or triple rim board was viewed as a detrimental cost implication. One suggestion was made to use squash blocks at each joist.
- Modular construction – based on the presentation of the initial Shear Wall testing, the discussion centered on use of sheathing panels that are required to span the extended plates. The perspective from modular construction was that vertical sheathing and gypsum drywall at bottom of the wall are needed for secure transporting of walls connected to floors and ceiling during transport. Horizontal rather than vertical sheathing is used for this purpose. Vertically installed sheathing could be feasible if the wall was designed/built at 8 feet with a 10-foot panel or a 9-foot wall with 11-foot panel. Hurricane standard for this plant still needs to be addressed.
- Modular construction – concerns over sheathing attachment which in modular is more advantageous to use horizontal sheathing for transport security. Sheathing changes however could be modified and still be applicable to the production process. Use of new nailing guns and nails is not a major issue for them.

- Roof truss – one builder raised a concern with the truss attachment to the extended plate at the top of the wall.
- Air sealing – concerns were raised with creating increased air sealing requirements due to multiple rim joists all the way around the building and the potential for more air infiltration at sills. This concern also acknowledged that all of these infiltration passages can be addressed with a continuous air barrier and proper use of sealants and caulks at strategic locations.
- Learning curve – associated constructability issues included costs of retraining for the framer which was viewed as a liability and may include other “nuisance costs” (e.g., sheathing orientation and length).
- Factory panelization – fabrication of EP&B panels would require modified equipment to accommodate the nails and nailing pattern required. Shipping the EP&B would be easier than with exterior foam. Site installation of EP&B panels would require modified corner details. Likewise, use of the continuous rim may be complicating and add unnecessary cost.

### **Stakeholder Review – EP&B Design and Construction Enhancements**

Based on the stakeholder review and discussion of the EP&B proposed wall system, the following enhancements are either planned for future design iterations or have been included in design changes:

1. Multiple rim components:  
The added cost and complexity of installing multiple rim members is considered an important design detail for improvement. Subsequent laboratory structural testing demonstrated that a double rim member would be sufficient for both shear and gravity loads. The double member could also serve as a header in most standard sized window openings. Future shear testing will include designs that use a single standard rim member.
2. Location of and insulating the rim member:  
Multiple discussions demonstrated the need for a “design consistency” in employing a layer of rigid insulation to the exterior of the rim board. While the exterior insulation of the rim is less critical due to the interior insulation options for the rim area that exceed the limitations of the cavity. Subsequent laboratory structural testing has demonstrated sufficient structural performance when the rim member is installed one inch inside from the outer edge of the plate. The structural performance is sufficient both for shear and gravity loads.
3. Sheathing attachment using 4-inch long nails:  
The EP&B wall system uses 2-inch thick foam between the structural sheathing and the studs. In order to develop a 1.5-inch nail penetration, 4-inch nails are required, longer than the standard 3.0 to 3.5 inches. Most standard nail guns are designed for nails up to 3.5 inches in length. Longer nails require fastener devices that are somewhat larger and heavier; requiring the trade contractors to invest in another tool set. At least one manufacture of nail guns was found that designs a nail gun that can accommodate nails up to 4 inches in length. The primary limitation of standard nail guns is the nail cartridge, a relatively inexpensive component of the hardware.

Given sufficient demand, tool design modifications to accept up to 4-inch nail lengths would appear reasonable in this regard.

4. Wall moisture performance:

Wall moisture concerns, specifically the condensation potential in the sheathing in higher efficiency walls. The concern stems from the reduced drying potential in the wall cavity due to higher levels of insulation and lower air infiltration rates. In addition, the use of material combinations that have lower perm ratings can slow drying. In some homes where infiltration rates have been reduced without use of ventilation, the indoor humidity levels may increase causing a higher outward vapor pressure in winter. Home Innovation has instrumented one home in climate zone 5 to measure the changes in sheathing moisture content in the EP&B system. Additionally EP&B wall systems are installed in a test hut in climate zone 4 to obtain similar data. An initial set of simulations using WUFI software has shown typical cyclic moisture content in the sheathing for the EP&B system under assumed conditions. Other Building America review of the system has not raised any particular moisture management concerns for the EP&B system due to the configuration of materials.

5. Air sealing:

Due to the configuration of materials, the infiltration performance of the wall system, including the rim area, requires investigation. To this end, a test house is planned such that the ceiling drywall will be installed prior to the wall insulation and drywall. With the ceiling air sealed, the building infiltration rate can be measured, in particular during various stages of air sealing. During the infiltration test, air leakage pathways will be investigated using standard diagnostic tools.

6. Complex framing variations:

As experience with the EP&B wall system expands, variations in wall layouts will be encountered. For example, wall sections framing atrium rooms may be 12 to 16 feet or more in height will require unique framing details for the EP&B system. This is consistent with any wall framing system, however for the EP&B system, the unbroken structural sheathing span between the plates may limit the section height for tall walls. Likewise, oblique angle walls, for example at bay windows, will require slight variations in the wall section attachment, although these differences would be minor. Variations in framing details will be developed based on actual field experience and unique home designs.

### **EP&B Building Code Review**

A meeting with New York State Codes Division staff was held on March 6, 2014 in Albany, NY at the NYS Department of State, Code Division meeting room.

The meeting was attended by Joseph Hill, R.A., Assistant Director for Energy Services, NYS Codes Division; and Mike Burnetter, P.E. Senior Engineer For Energy Services, NYS Codes Division. The EP&B wall system background and need was presented by Vladimir Kochkin and Joe Wiehagen of the Home Innovation Research Labs, and Philip LaRocque of the LaRocque Business Management Services, LLC.

The primary purpose of the meeting was to review design details for the EP&B wall system and independently assess the constructability of the wall system based on the initial proposed construction approach and identify specific building code or inspection issues that might be anticipated as the EP&B system gains traction in residential new home construction. One specific outcome from the meeting was to determine if the EP&B wall system meets current NYS code (IRC and ECC) and would be expected to meet the new NYS codes to be finalized in early 2015. If the EP&B wall system was determined to not meet current building code requirements, the additional purpose of the meeting would be to identify design changes necessary to have the wall system accepted for these codes.

Acknowledged early on was one limitation of the wall design in its applicability in hurricane zones. Since NYS has hurricane zones along the coast, further design and engineering, likely including testing, would be necessary if the EP&B system were to be used in these high wind areas.

Outside of the high wind areas though, no impediments to use of the EP&B system were identified.

Requirements for siding attachment was discussed and determined that given the current 2010 NYS Energy Conservation Code changes that provide prescriptive attachment of siding through foam (Section 402.1.5 of the 2010 NYSECC), the EP&B system would not present any complications. [Similar siding attachment prescriptive requirements for attachment of siding through foam have been included in the 2015 IRC.]

Home Innovation staff raised the concern expressed by builders of moisture management in high performing (energy efficient) wall systems. Ongoing moisture studies by the Home Innovation was of interest to the meeting participants and forthcoming reports will be provided when complete. The NYS Codes Division staff identified concerns from the Wood Council on moisture handling capability of the OSB sheathing when overlaid with foam sheathing products. It was noted that the EP&B wall system design mitigates this concern. Though not specifically related to the EP&B system, it was also noted that Class 1 vapor retarders were going to be disallowed in the upcoming code changes.

When discussing parallel changes to the International Residential Code (IRC), it was noted that State code modifications to date are based on the 2012 ICC documents. While the time frame for adoption of the new code is unknown, there is doubt that the 2012 ICC will be superseded immediately by the 2015 ICC (which have just recently been published) as the baseline code reference. Also noted; since NYS has now uses the ICC codes as a basis (with state modifications) it has always lagged the ICC updates by at least a year to allow for other states to experience the ICC latest changes first.

Finally, the code officials did not see any problem (except in high wind areas) at this time in having the EP&B wall system used under the current code and the NYS modifications coming in the near future.

### **EP&B Building Code Applicability**

The stakeholder review and a similar review by building code officials indicate continuation of the development of the EP&B system is warranted and beneficial to the residential building industry. Based on these reviews, further laboratory testing was performed and various details, particularly in the rim design, were modified, resulting in improved thermal performance and simplified installation

Thus far, the EP&B system may be used in residential construction that is allowed by the International Residential Code (IRC). However, using the requirements of the IRC, the EP&B system must be engineered at this time since prescriptive requirements have yet to be developed and submitted for approval through the ICC code making process.

## Example Building Code Prescriptive Requirements for the EP&B Wall System

A draft example set of prescriptive IRC provisions for the EP&B wall system, based on 2015 IRC, have been outlined, demonstrating how the EP&B wall system might be incorporated into the IRC. While these example provisions are based on current laboratory testing and field implementation, they are for demonstrative purposes only, indicating where the prescriptive requirements would fit into the existing IRC code and how these example provisions might modify other sections of the IRC. In order for any building code change proposal to be submitted for the EP&B system, repetitive testing results will be required.

---

### Example IRC provisions applicable for the EP&B wall system:

Add new definition to Section R202

**EXTENDED PLATE WALL (EPW).** A wood framing method for constructing exterior walls using the top and bottom plates wider than the width of the studs such that rigid foam sheathing can be inset between the studs and the exterior wood structural panel sheathing.

*(Note – the name of the wall system has been modified from the Extended Plate and Beam to the Extended Plate Wall system. This was done to avoid confusion of a beam design or a beam requirement. Based on further laboratory testing, the original beam concept has been shown as a less critical part of the system design and thus is not required as part of the definition or code requirements.)* Add new section to IRC Chapter 6.

**602.13 Extended Plate Wall (EPW).** Framing, wood structural panel sheathing, connections, wall bracing, and anchorage for the EPW shall be in accordance with all applicable provisions of Sections R602.1 through R602.12 as modified by the provisions of Section R602.13.

**602.13.1 Plates.** The bottom plate and the upper top plate shall be of equal width and shall be wider than the width of the studs, by not more than 2 inches, in accordance with Figure R602.13.1. Where a double plate is used, the plate directly attached to the stud shall be the same width as the stud width.

**602.13.2 Wood structural panel sheathing attachment.** Wood structural panel sheathing shall be attached to wall plates and studs at the panel perimeter and to studs in the panel field with nails providing a minimum penetration of 1-1/2 inches into plates and studs. Different nail sizes are permitted to be used at plates and studs.

**602.13.3 Horizontal joints in wood structural panels.** Where used as part of wall bracing, each wood structural panel shall be continuous between the extended top and bottom plates. Blocking of panel edges shall not be an acceptable alternative to continuous wood structural panels.

**602.13.4 Wall Bracing.** Wall bracing shall be in accordance with the WSP Bracing Method in Table R602.10.4 except the fasteners' diameters and spacing shall be in accordance with

Table R602.13.4. All provisions applicable to the use of the WSP Bracing Method, including provisions for mixing bracing methods, shall be applicable to EPW.

**Table R602.13.4 Braced Wall Fastener Requirements**

| Minimum nail diameter | Fastener Spacing         |          |
|-----------------------|--------------------------|----------|
|                       | At Top and Bottom Plates | At Studs |
| 0.131"                | 3" oc                    | 6" oc    |

**602.13.4.1 Simplified Wall Bracing.** With the exception of Section R602.12.2 Item 2 and Section R602.12.3 Item 1, provisions of Section R602.12 shall be applicable to the EPW. The fastening schedule for wood structural panels shall be in accordance with the additional requirements of Table R602.13.4.

**602.13.5 Rim joist.** Rim joists (band joists) installed above an EPW or supporting an EPW shall be a minimum 1-1/8 inch double member or minimum 2-1/4 inch single rim member . Rim joists are permitted to be inset by 1 inch from the exterior framing surface to provide space for exterior rigid insulation. The minimum bearing length requirements for the floor joists shall be satisfied or joists shall be supported with metal hangers.

**602.13.6 Headers.** Where the rim joist framing and supporting full-height studs are constructed in accordance with Section R602.7.2 or an equivalent alternative, no additional headers are required at openings.

**602.13.7 Door bucks.** On each side of door openings, door frames shall include a stud with the width equal to the width of the top and bottom plates. (Figure R602.13.7)

**602.13.8 Foam plastic sheathing.** Foam plastic sheathing with a maximum total thickness of 2 inches shall be installed between the studs and the exterior wood structural panels. The foam plastic sheathing shall be extruded polystyrene in accordance with ASTM C 578 or polyisocyanurate in accordance with C1289. It is permitted to apply spray foam with maximum permeance of 1.5 perms to the interior cavity side of the foam plastic.

**602.13.9 Vapor Retarder.** A vapor retarder on the interior side of the frame shall be in accordance with Section R702.7 except:

1. Class I vapor retarder shall not be permitted.
2. Class II vapor retarder shall be kraft paper or an approved equivalent.
3. Where Class III vapor retarder is installed in accordance with Section R702.7.1, the requirements for walls with continuous insulation shall be followed.
4. Where spray foam is installed to the interior cavity side of the foam plastic sheathing, it is permitted to use combined through-the-cavity insulation R-value for use with Section R702.7.1.



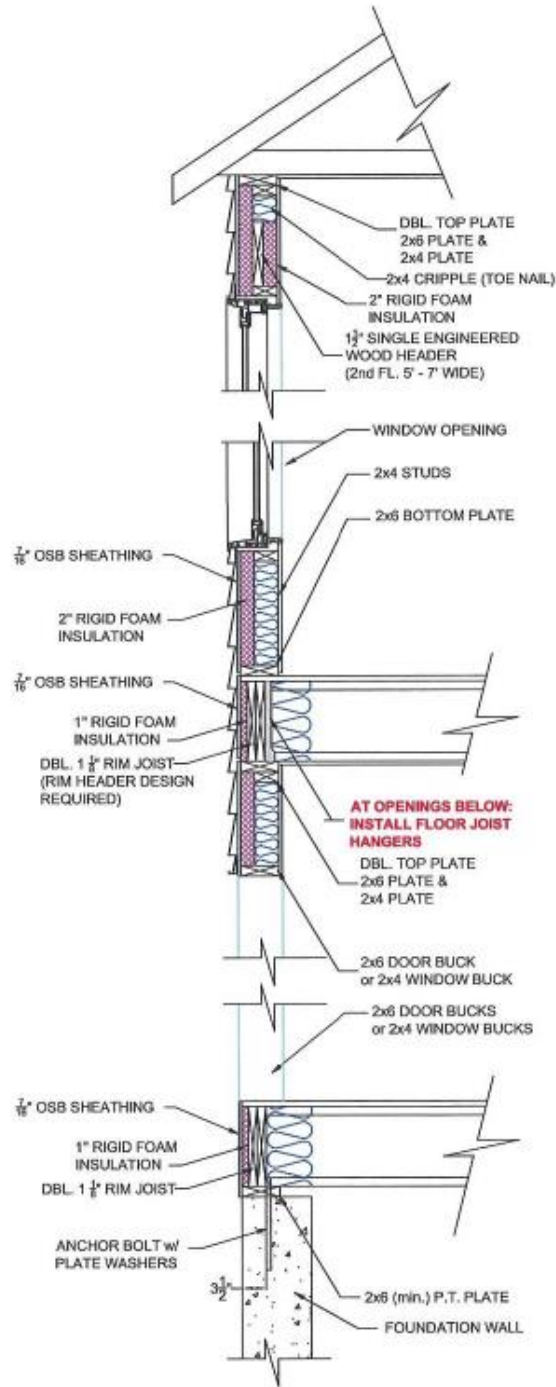

Figure R602.13 Extended Plate Wall (EPW) System

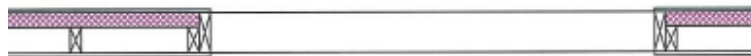

Figure R602.13.7 Full-width studs (bucks) at door openings

## Summary and Next Steps

The results of the overall assessment summarized in this report support the viability of the EP&B wall system and warrant continued refinement of the system and development of further substantiating materials on the system's performance.

Construction of walls using the EP&B system has been proposed for projects in New York State. Other projects to perform laboratory testing to develop test results suitable for use in IRC code change proposals are being considered. Based on field testing and revised design details, selected EP&B wall system configurations will be developed as specimens for repetitive testing and documentation. Additional laboratory testing on full scale mock-ups that include openings, will be performed as needed for development of more detailed design specifications.

The EP&B wall system enables wall system construction with R-values 50% or more above standard code requirements. The major advantage to use of the EP&B system is the straightforward approach using common methods and materials used by the industry today. Wide spread application of the wall system in new residential construction will be encouraged through the development of a design guide. The development of such a guide is planned as a final step in the maturation of the EP&B system.



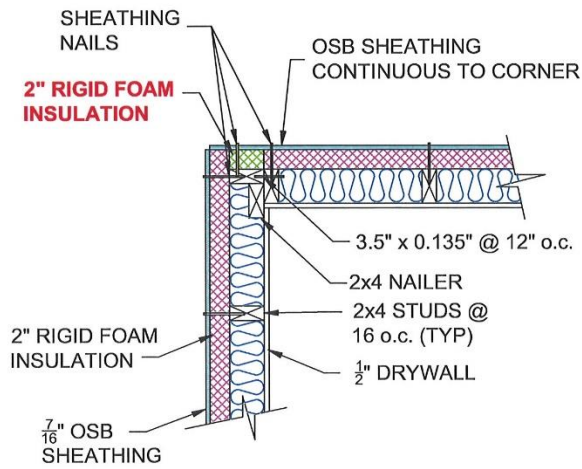

**OPTION 1: CONTINUOUS EXTERIOR FOAM**

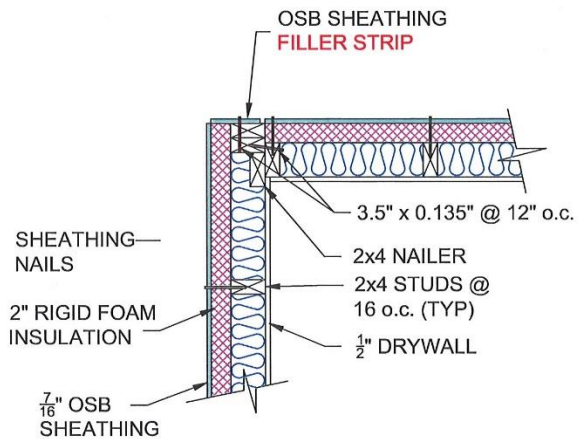

**OPTION 2: 2x4 STUDS & OSB FILLER**

**OUTSIDE CORNER DETAIL  
ON EXTERIOR WALL**

**BRACING: IRC PRESCRIPTIVE APPLICATIONS  
EXAMPLE DETAILS ONLY  
NOT FOR CONSTRUCTION**

HOME INNOVATION RESEARCH LABS

EXTENDED PLATE & BEAM DETAILS  
2x4 STUDS w/ 2x6 PLATES

PAGE C1-4

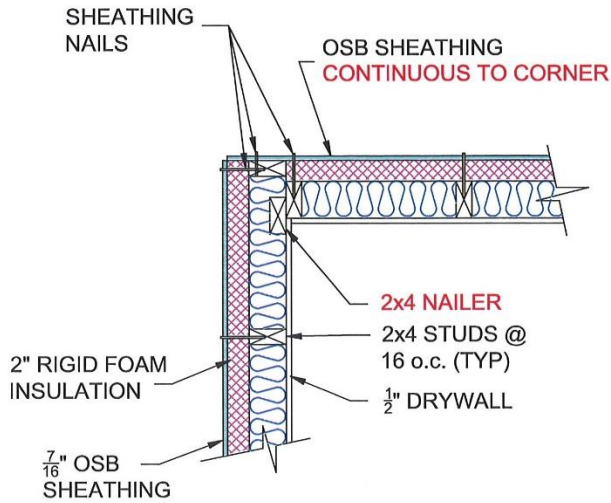

**OPTION 3: 2x4 STUDS AND CONTINUOUS OSB**

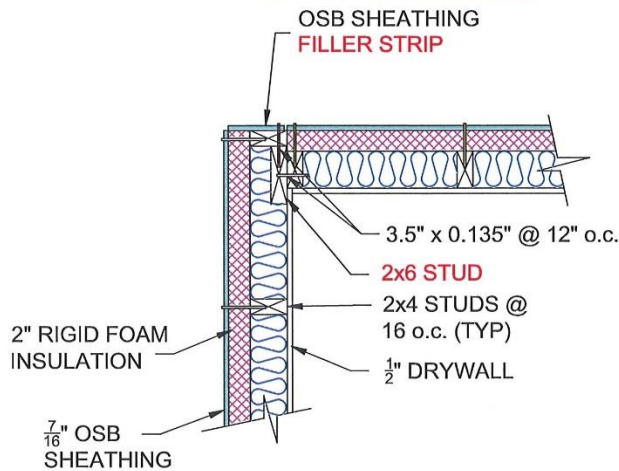

**OPTION 4: 2x6 STUD AND OSB FILLER**

**OUTSIDE CORNER DETAIL ON EXTERIOR WALL**

NOTE: GYPSUM NAILERS CAN BE SUBSTITUTED WITH APPROVED CORNER CLIPS

**BRACING: IRC PRESCRIPTIVE APPLICATIONS  
EXAMPLE DETAILS ONLY  
NOT FOR CONSTRUCTION**

HOME INNOVATION RESEARCH LABS

EXTENDED PLATE & BEAM DETAILS  
2x4 STUDS w/ 2x6 PLATES

PAGE C1-3

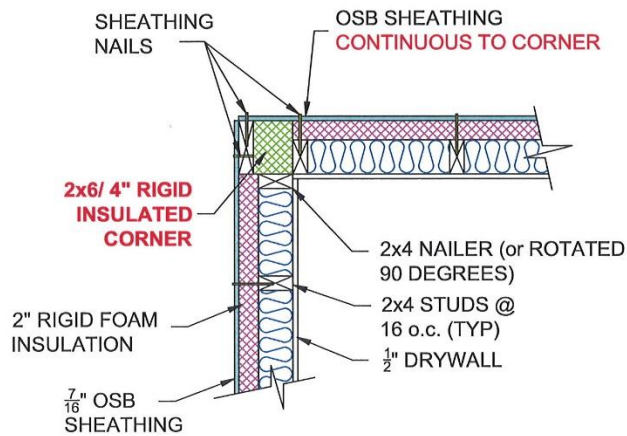

**OPTION 5: INSULATED CORNER POST  
CONTINUOUS OSB**

(e.g. Weyerhaeuser Insulated Structural Corner)

NOTE: GYPSUM NAILERS CAN BE  
SUBSTITUTED WITH APPROVED  
CORNER CLIPS

**BRACING: IRC PRESCRIPTIVE APPLICATIONS  
EXAMPLE DETAILS ONLY  
NOT FOR CONSTRUCTION**

HOME INNOVATION RESEARCH LABS

EXTENDED PLATE & BEAM DETAILS  
2x4 STUDS w/ 2x6 PLATES

PAGE C1-5

**OUTSIDE CORNER DETAIL  
ON EXTERIOR WALL**

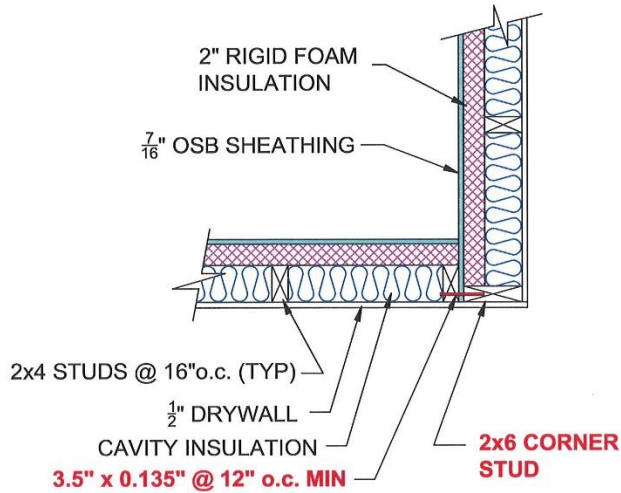

**OPTION 1: 2x6 END STUD**

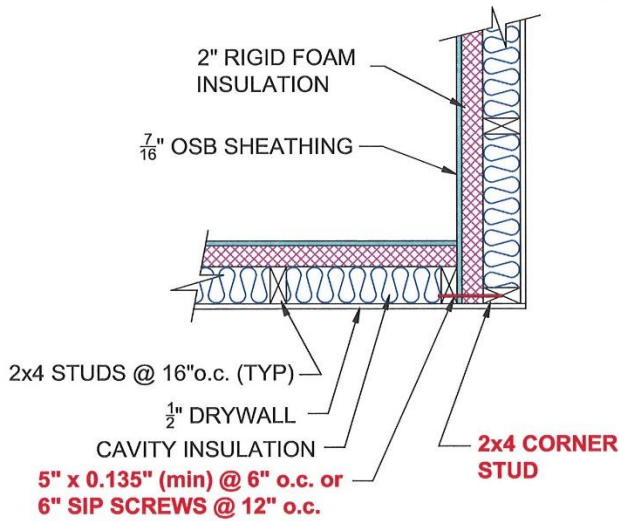

**OPTION 2: 2x4 END STUD**

**INSIDE CORNER DETAIL**  
**ON EXTERIOR WALL**

**BRACING: IRC PRESCRIPTIVE APPLICATIONS  
EXAMPLE DETAILS ONLY  
NOT FOR CONSTRUCTION**

HOME INNOVATION RESEARCH LABS

EXTENDED PLATE & BEAM DETAILS  
2x4 STUDS w/ 2x6 PLATES

PAGE C1-6

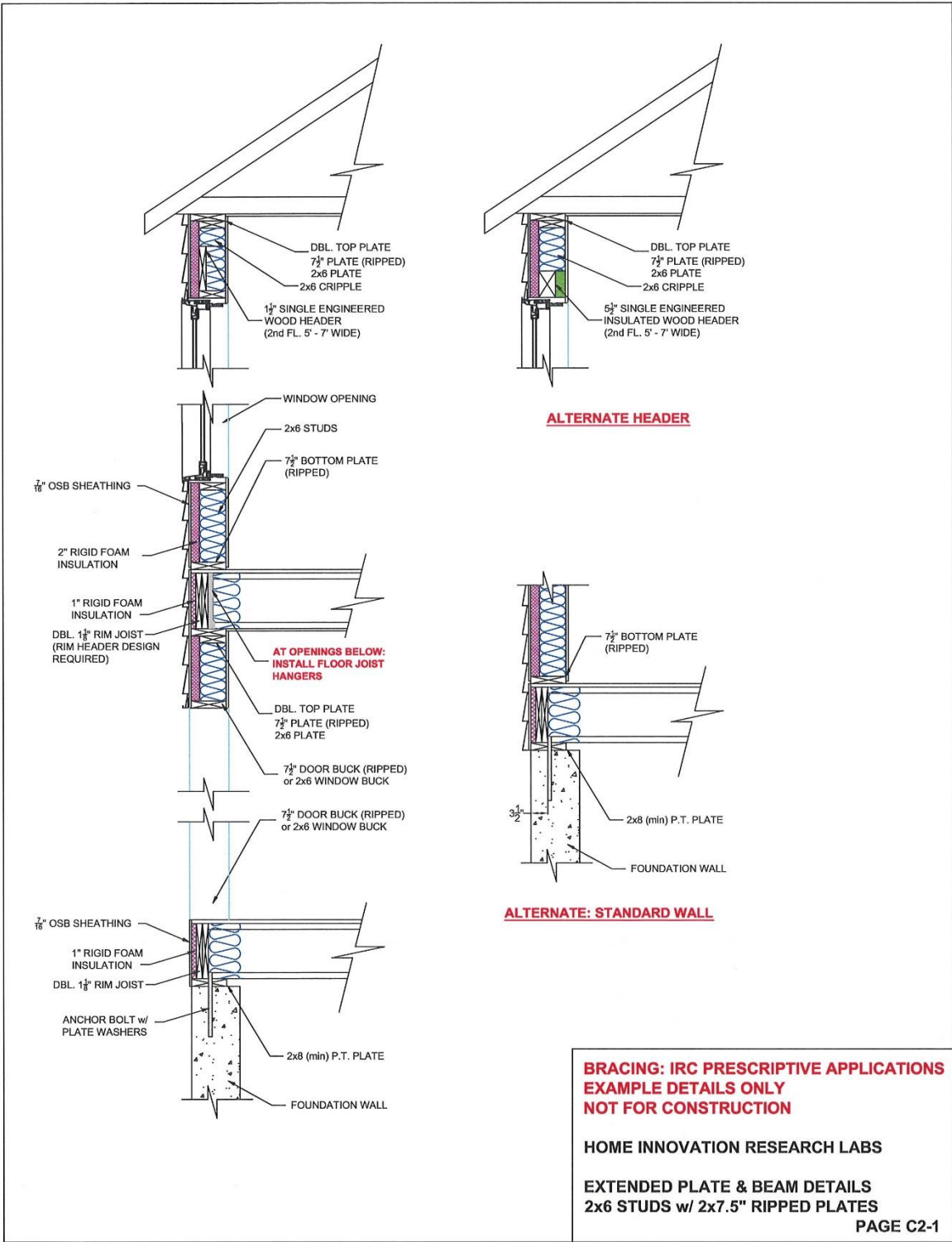





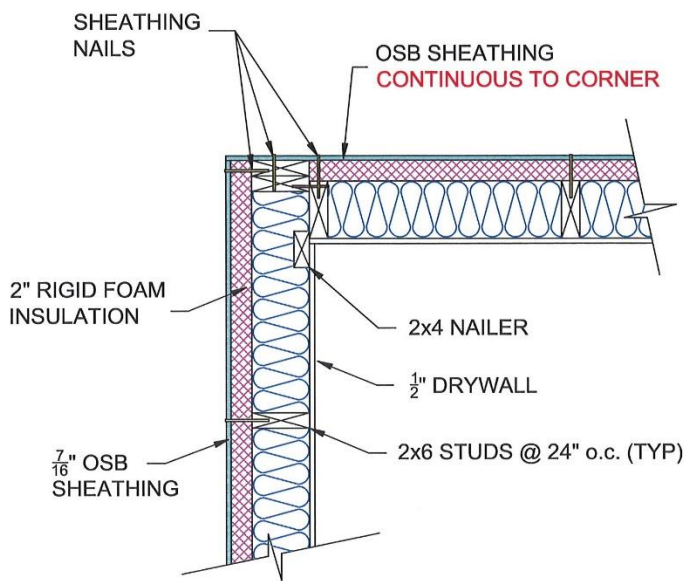

**OPTION 1: (2) 2X6 w/ CONTINUOUS OSB**

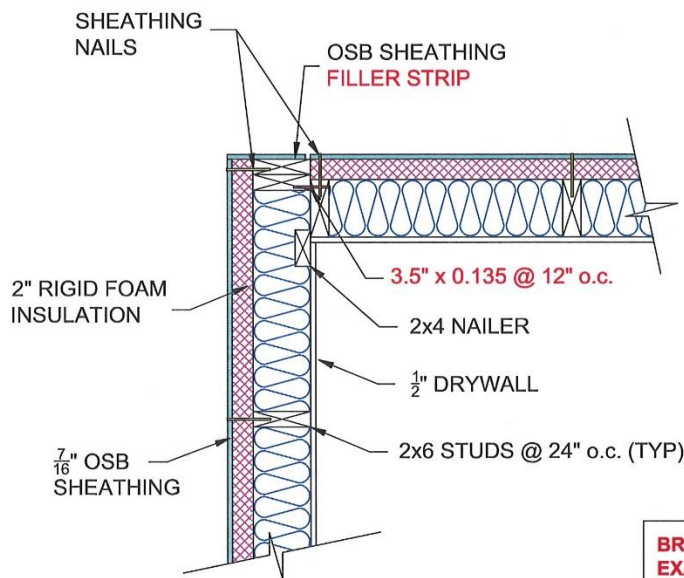

**OPTION 2: (2) 2X6 w/ OSB FILLER**

NOTE: GYPSUM NAILERS CAN BE SUBSTITUTED WITH APPROVED CORNER CLIPS

**BRACING: IRC PRESCRIPTIVE APPLICATIONS  
EXAMPLE DETAILS ONLY  
NOT FOR CONSTRUCTION**

HOME INNOVATION RESEARCH LABS

EXTENDED PLATE & BEAM DETAILS  
2x6 STUDS w/ 2x7.5" RIPPED PLATES

PAGE C2-3

**EXTERIOR OUTSIDE CORNER DETAIL**

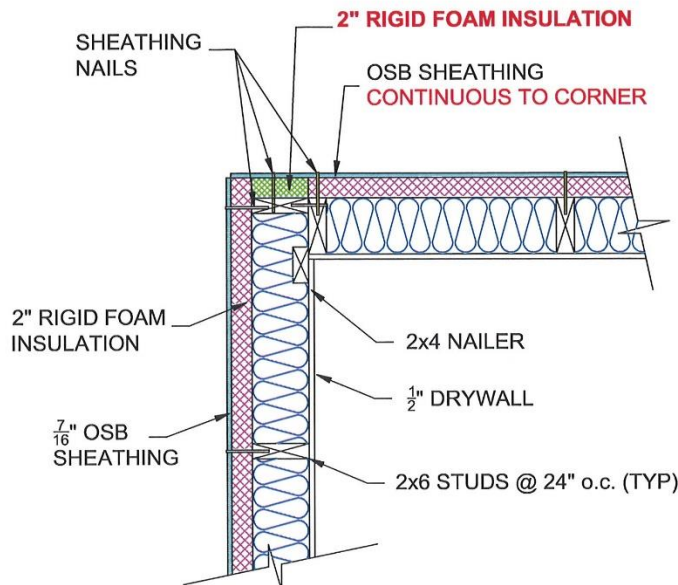

**OPTION 3: CONTINUOUS EXTERIOR  
FOAM & CONTINUOUS OSB**

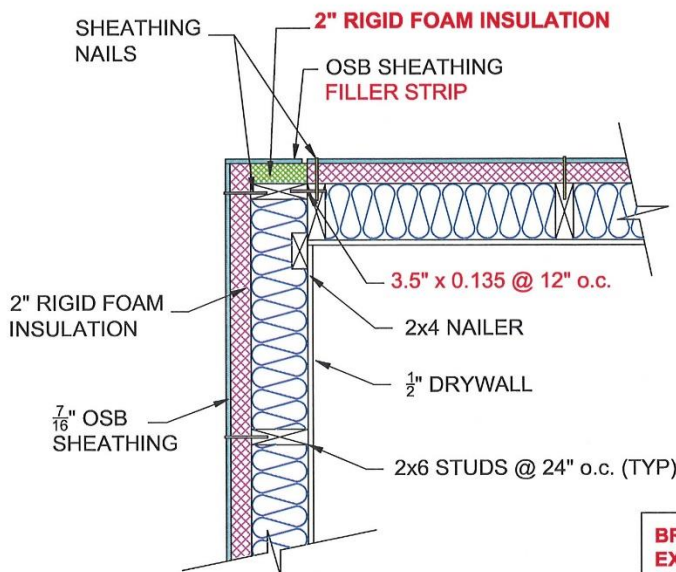

**OPTION 4: CONTINUOUS EXTERIOR  
FOAM & OSB FILLER**

**EXTERIOR OUTSIDE CORNER DETAIL**

NOTE: GYPSUM NAILERS CAN BE  
SUBSTITUTED WITH APPROVED  
CORNER CLIPS

**BRACING: IRC PRESCRIPTIVE APPLICATIONS  
EXAMPLE DETAILS ONLY  
NOT FOR CONSTRUCTION**

HOME INNOVATION RESEARCH LABS

EXTENDED PLATE & BEAM DETAILS  
2x6 STUDS w/ 2x7.5 RIPPED PLATES

PAGE C2-4

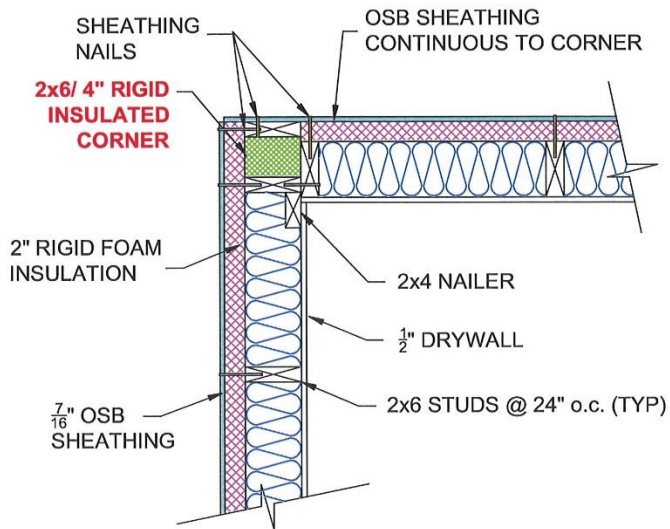

**OPTION 5: INSULATED CORNER POST**

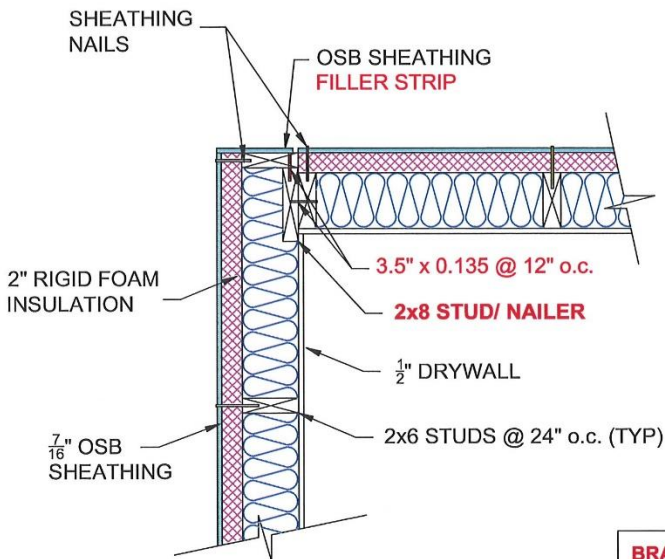

NOTE: GYPSUM NAILERS CAN BE SUBSTITUTED WITH APPROVED CORNER CLIPS

**OPTION 6: 2x8 STUD AND OSB FILLER**

**EXTERIOR OUTSIDE CORNER DETAIL**

**BRACING: IRC PRESCRIPTIVE APPLICATIONS  
EXAMPLE DETAILS ONLY  
NOT FOR CONSTRUCTION**

HOME INNOVATION RESEARCH LABS

EXTENDED PLATE & BEAM DETAILS  
2x6 STUDS w/ 2x7.5" RIPPED PLATES

PAGE C2-5

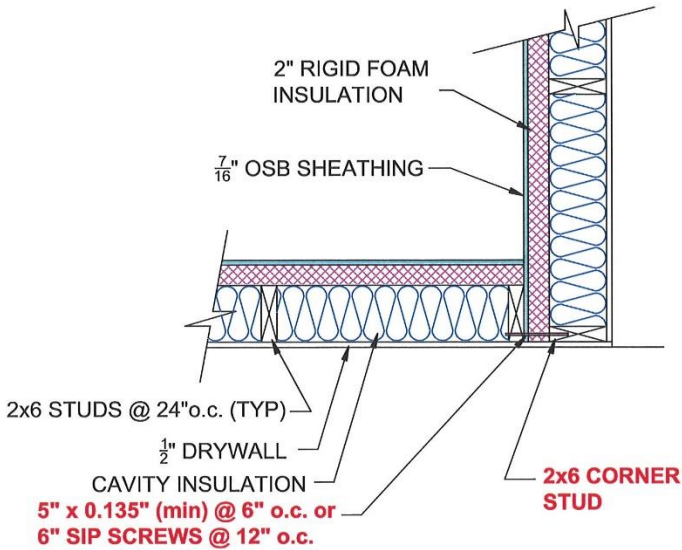

**OPTION 1: 2x6 END STUD**

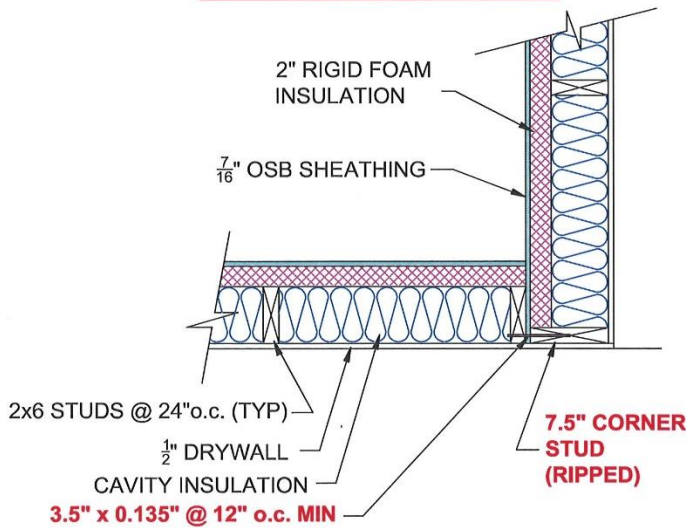

**OPTION 2: 7 $\frac{1}{2}$ " END STUD (RIP)**  
**INSIDE CORNER DETAIL**  
**ON EXTERIOR WALL**

**BRACING: IRC PRESCRIPTIVE APPLICATIONS**  
**EXAMPLE DETAILS ONLY**  
**NOT FOR CONSTRUCTION**

HOME INNOVATION RESEARCH LABS

EXTENDED PLATE & BEAM DETAILS  
2x6 STUDS w/ 2x7.5" RIPPED PLATES

PAGE C2-6

## Appendix B. EP&B Framing Scope of Work

### 1. Introduction

- 1.1. This scope of work addresses the construction procedure for field-framed Extended Plate and Beam (EP&B) walls in a two-story building with a basement or a crawlspace.
- 1.2. This scope of work addresses the EP&B configuration constructed using 2x4 stud and 2x6 plates (Configuration 1).
- 1.3. The construction procedure addresses framing and sheathing (including structural and foam sheathing).
- 1.4. The primary focus is on the methods and materials that are unique to the EP&B system or impacted by the EP&B system design. Where framing practices are not altered by the EP&B design, typical construction methods and material shall be followed.
- 1.5. All headers shall be in accordance with building code or approved engineered design.
- 1.6. With exception of wall structural sheathing nailing schedule that is unique to the EP&B system, all fastening requirements are consistent with building code requirements for light-frame wood walls as applicable. Approved alternatives shall be permitted.
- 1.7. For additional information, refer to construction details provided with the Scope of Work.

### 2. Material List

- 2.1. Dimension lumber: Stud grade or higher
- 2.2. Wall sheathing: wood structural panels (WSP) - plywood or oriented strand board (OSB) with minimum 7/16 inch thickness
- 2.3. Engineered wood rim board
- 2.4. Metal joist hangers (at first-floor openings only – rim header application) per engineered design
- 2.5. Structural composite lumber (second-floor headers and rim joist application at first floor)
- 2.6. Insulating rigid board foam sheathing (XPS or Polyisocyanurate)
- 2.7. Fasteners per construction details
- 2.8. WSP floor sheathing and engineered floor joists per building plans

### 3. Field-Framing Guidelines

#### 3.1. **Sill plate and First Floor Construction**

- 3.1.1. Verify sill plate anchor bolt size and spacing is in accordance with the house plans. The anchor bolt edge distance from exterior edge of the foundation wall should be approximately 3.5 inches to allow for the double rim joist installation.
- 3.1.2. Install minimum 2x6 pressure treated sill plate and secure using nuts over an appropriately-sized washer.
- 3.1.3. Install a double 1-1/4 inch engineered wood rim joist faced-nailed at a nominal spacing of 24 inches on center at top and bottom edges and toe-nailed to sill plate on the exterior face with 8d nails (2-1/2" x 0.113") at 6 inches on center.

3.1.4. Install engineered floor joists and floor sheathing in accordance with the building plans.

**3.2. Wall construction**

3.2.1. Layout 2x6 bottom (sole) plate.

3.2.2. Layout 2x4 studs @ 16 inches on center.

3.2.3. Layout first top plate (2x4 framing).

3.2.4. Attach bottom plate to studs and first top plate to studs using (2) 3½"x0.135" nails at each connection.

3.2.5. Attach second top plate (2x6 framing) to the first top plate using 10d nails (3"x0.128") at 24 inches on center. End joints in double top plates shall be offset at least 24 inches and a minimum of eight (8) 10d nails (3"x0.128") shall be installed in the lapped area. In lieu of the offset, double top plates may be fastened to each other with an approved metal plate connector.

3.2.6. Mark the plates with the location of studs (will be needed for attaching WSP sheathing after foam sheathing is installed).

3.2.7. Install 2-inch-thick rigid foam sheathing over 2x4 studs between 2x6 top and bottom plates. The foam sheathing can consist of two layers of 1-inch-thick panels or a single 2-inch-thick layer. Rigid foam sheathing shall fill the entire space between the 2x6 top and bottom plates except at openings (see Sections 3.3 and 3.5 for framing at openings). The edge/end joints of foam sheathing panels shall be tight against each other and against 2x6 plate framing members. A rigid foam sheathing panel or a panel section shall span at least one stud bay. Where a double foam layer is used, it is recommended that joints are offset between the two layers.

3.2.8. Install WSP sheathing over the insulating rigid foam sheathing. The WSP sheathing shall be oriented vertically and shall be continuous between top and bottom 2x6 plates. Horizontal WSP orientation or horizontal joints in WSP sheathing shall not be permitted (blocked or unblocked). WSP sheathing shall overlap top and bottom plates by a minimum of 1 inch to allow installation of sheathing nails. All vertical edges shall occur over studs. Use of elongated WSP panels that extend over the rim joists below and/or above the wall is permitted.

3.2.9. Allow 1/8-inch space at all WSP edges (or in accordance with WSP manufacturer's recommendations).

3.2.10. Attach WSP sheathing to 2x6 top and bottom plates and to 2x4 studs using nails in accordance with the following schedule:

- At 2x6 top and bottom plates: a minimum 2½"x0.131" at maximum 3 inches on center.
- At 2x4 studs through foam sheathing: a minimum 4"x0.131" at maximum 6 inches on center (at panel edges and in the field) to allow 1.5-inch penetration into the framing

Note: 4 inch long nails can be also used at plates to minimize the number of nail sizes at the job site.

### 3.3. First Floor Openings

- 3.3.1. Window bucks are framed using 2x4 studs.
- 3.3.2. Door bucks are framed using 2x6 studs to provide for direct attachment of WSP sheathing to achieve a greater stiffness of the door frame.
- 3.3.3. The space above all openings is framed as for a non-bearing wall (rim header design – see Section 3.4).
- 3.3.4. Horizontal door/window buck at the top of the opening shall be a continuous member and shall be attached to the exterior WSP sheathing using sheathing nails at 6 inches on center (to provide support for the horizontal buck member).
- 3.3.5. The number of king studs shall be determined based on the size of the opening in accordance with Table SW-1 or approved engineered design. (Note: a window or door buck continuous from bottom to top plate is a king stud.)

**Table SW-1. Number of King Studs at First Floor Openings (Rim Header)<sup>1</sup>**

| Opening Width, ft | At Window Opening | At Door Opening <sup>2</sup> |
|-------------------|-------------------|------------------------------|
| 3                 | 1                 | 1                            |
| 4                 | 2                 | 1                            |
| 6                 | 3                 | 2                            |
| 8                 | 3                 | 2                            |
| 10                | 4                 | 3                            |
| 12                | 5                 | 4                            |

- 1. The number of king studs at each side of the opening.
- 2. Number of king studs is reduced at door opening because the first stud (buck) is a 2x6 member.

- 3.3.6. WSP sheathing is connected to window or door bucks using 4"x0.131" nails at 6 inches on center (2½"x0.131" nails are permitted for use with 2x6 door bucks where sheathing applied directly to framing.)

### 3.4. Rim Headers and Second Floor Construction

- 3.4.1. Install double 1-1/4 inch engineered wood rim joist along the entire perimeter of the wall.
- 3.4.2. Rim joists shall not have splice joints over an opening and the first splice joint to each side of the opening shall occur a minimum of 6 inches away from the opening edge and past the outermost king studs (rim header application).
- 3.4.3. Double rim joist shall be faced-nailed at top and bottom edges at a nominal spacing of 24 inches on center and at 16 inches on center over openings with minimum



- 2.5"x0.131" nails. The exterior rim shall be toe-nailed to top plate with 8d nails (2-1/2" x 0.113") at 6 inches on center.
- 3.4.4. The maximum rim joist span shall be verified by a licensed professional. (Note: A double 1¼ x11.875 structural composite lumber member is sufficient for most openings up to 8-feet wide).
  - 3.4.5. Install engineered wood floor joists in accordance with the floor plans.
  - 3.4.6. Floor joists located above an opening shall be supported by a metal joist hanger selected by a licensed professional based on design loads.
  - 3.4.7. Install WSP floor sheathing in accordance with the building plans.
- 3.5. **Top Floor Openings**
- 3.5.1. Top floor openings are conventionally framed using single 1¼-1½-inch thick engineered wood headers (up to 5-7 feet) or double engineered wood headers (for larger openings).
  - 3.5.2. Where single header is used, it is insulated with 2-inch rigid foam sheathing on the interior face of the header.
  - 3.5.3. Headers are supported by jack studs. The number of jack studs and king studs is determined based on standard practice in accordance with building code or engineered design.
- 3.6. **Corner Details (Exterior Walls)**
- 3.6.1. Construct wall corners at intersecting exterior walls using one of the details provided with this Scope of Work.
  - 3.6.2. Framing members at the corners are arranged in a manner to minimize thermal bridging and allow for increased quality and level of insulation installation. Rigid foam sheathing insulation is installed at the corners as provided on the details.
  - 3.6.3. The intersecting walls shall be connected to each other at the corner using one of the options:
    - Adjacent framing members are nailed directly to each other using 3.5"x0.135" nails at 12 inches on center.
    - Adjacent framing members that are separated by up to 2 inches of rigid foam sheathing insulation are nailed to each other using 5"x0.135" nails at 6 inches on center or using 6"x0.190" SIP screws at 12 inches on center.
    - Exterior WSP sheathing from both intersecting walls is nailed directly to a common 2x framing member using minimum 2.5"x0.131" nails spaced a maximum of 6 inches on center (for each wall).
    - Other approved fastening methods.
  - 3.6.4. Double top plates are overlapped at corners and intersections and two (2) 3"x0.128" nails installed at each lap (face-nailed). Alternatively, the intersecting walls are fastened to each other with an approved metal plate connector.

# Appendix C. EP&B Introduction Presentation Materials for Stakeholder Groups



## Extended Plate and Beam Wall System

### Stakeholder Meeting

NYSERDA

March 2014

Home Innovation RESEARCH LABS

Buildings AMERICA U.S. Department of Energy

## Meeting Outline

- Meeting Objectives
- Background
- EP&B System
- EP&B Research To Date
- Discuss EP&B details and attributes
- Discuss EP&B constructability
- Summarize feedback and input

Home Innovation RESEARCH LABS

## Meeting Objectives

- Obtain feedback and input from stakeholders on the EP&B system
- Identify system attributes valued by stakeholders
- Identify system attributes that can be improved to facilitate adoption
- Identify strategies for successful implementation

Home Innovation RESEARCH LABS

## Background

- Technologies for high-R walls have been proposed and used for over 25 years
- But real market penetration is very low
- Often the last EE measure implemented by builders (e.g. E\*)

Home Innovation RESEARCH LABS

## Background

- High-R wall solutions have not achieved a broad level of standardization and commonality
  - A large set of methods and materials entered the market
  - Multiple and conflicting details
- Wall characteristics are more critical = RISK

Home Innovation RESEARCH LABS

## Drivers for EE walls

- 2012 IECC, 2015 IECC
  - CZ 4&5: R20, R13+5
  - CZ 6: R20+5, R13+10
- Green Programs
- Energy Star
- DOE Challenge Home
- Utility savings, comfort, durability

Home Innovation RESEARCH LABS

### New Home Starts – Wall Framing

| FRAMING        | 2001        | 2006        | 2011        |
|----------------|-------------|-------------|-------------|
| 2x4 @ 16" o.c. | 74%         | 73%         | 57%         |
| 2x4 @ 24" o.c. | 2%          | 3%          | 4%          |
| 2x6 @ 16" o.c. | 22%         | 22%         | 32%         |
| 2x6 @ 24" o.c. | 2%          | 2%          | 6%          |
| Other          | 1%          | 0%          | 1%          |
| <b>TOTAL</b>   | <b>100%</b> | <b>100%</b> | <b>100%</b> |

Home Innovation RESEARCH LABS 7

### New Home Starts – Wall Sheathing

| FRAMING                           | 2001        | 2006        | 2011        |
|-----------------------------------|-------------|-------------|-------------|
| None (concrete, SIPs or others)   | 10%         | 12%         | 9%          |
| WSP (Plywood, OSB, ZIP)           | 65%         | 68%         | 80%         |
| 1/2 inch fiberboard               | 3%          | 3%          | <1%         |
| 1/8 inch (Thermopyl, EnergyBrace) | 3%          | 2%          | 3%          |
| SIS                               | n/a         | n/a         | 1%          |
| Foam (XPS, EPS, ISO)              | 17%         | 12%         | 5%          |
| Other                             | 3%          | 4%          | 0%          |
| <b>TOTAL</b>                      | <b>100%</b> | <b>100%</b> | <b>100%</b> |

Home Innovation RESEARCH LABS 8

### New Home Starts

#### Oversheathing

| Oversheathing                                    | 2006 | 2011 |
|--|------|------|
| Shares of Homes with 2nd Layer of Foam Sheathing | 7%   | 9%   |

#### Housewrap

| Housewrap            | 2006 | 2011 |
|----------------------|------|------|
| Homes with housewrap | 54%  | 75%  |

Home Innovation RESEARCH LABS 9

### New Home Starts – Cavity Insulation

| FRAMING          | 2006        | 2011        |
|------------------|-------------|-------------|
| Fiberglass batt  | 76%         | 68%         |
| Fiberglass blown | 7%          | 8%          |
| Spray foam       | 3%          | 11%         |
| Cellulose        | 11%         | 8%          |
| Other or none    | 3%          | 5%          |
| <b>TOTAL</b>     | <b>100%</b> | <b>100%</b> |

Home Innovation RESEARCH LABS 10

- ### Increasing Wall Insulation
- When builders are asked how would they go about increasing the wall R-value
    - About 60% say they would use 2x6 or increase the cavity R-value
    - Less than 15% say they would use exterior foam
- Home Innovation RESEARCH LABS 11

- ### Barriers to Adoption
- “Devil is in the details”
    - Claddings
    - Attachments/connections
    - Windows
    - Drainage plane
    - Trim
    - Air barriers
    - Vapor retarder
    - Etc etc etc
    - Framing layout
- Home Innovation RESEARCH LABS 12

### Wall Innovation Metrics

- High R (thermal and air barrier)
- High Performance
  - Durable, structural
- Build-able
- Low transition risk to builders
- ≈ R23+ (CZ 4 and higher)

Home Innovation RESEARCH LABS 13

### Current High-R Options

- Deeper cavity
  - Thermal bridging limitation
  - R-value limit
  - Practical wall thickness limit
- Ext Rigid Insul.
  - OSB behind foam
  - Cladding attachments
  - Foam attachment
  - Windows
  - Drainage plane
  - Panelization

Home Innovation RESEARCH LABS 14

### Is there another way?

- Hybrid: *Extended Plate & Beam System*
  - R23+
  - Integrated foam sheathing
  - Standard cavity (2x4 or 2x6)
  - OSB on the exterior, so is drainage plane
  - Standard building materials
  - Standard window installation
  - Site-built or panelized
  - Rim headers integral part of the system

Home Innovation RESEARCH LABS 15

### Feedback & Input Questions

- Which of these attributes do you see as an easy transition from your current practice?
- Which of these attributes do you see as having the steepest learning curve?
- Which of these attributes need further development?

Home Innovation RESEARCH LABS 16

### Extended Plate & Beam

- Plates and studs are different width
- R25 (2x4 studs & 2x6 plates)
- R30 (2x6 studs & 2x8 plates)

Home Innovation RESEARCH LABS 17

### What do we know so far?

- Concept has been shared with various stakeholders including builders, building science professionals, DOE, USDA
- An exploratory shear wall test performed, more testing underway
- A house is being framed in PA
- NYSERDA Project is underway
- Cost analysis

Home Innovation RESEARCH LABS 18

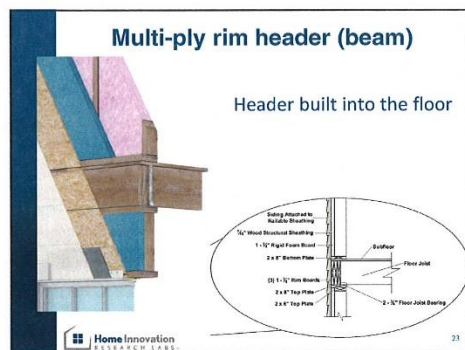
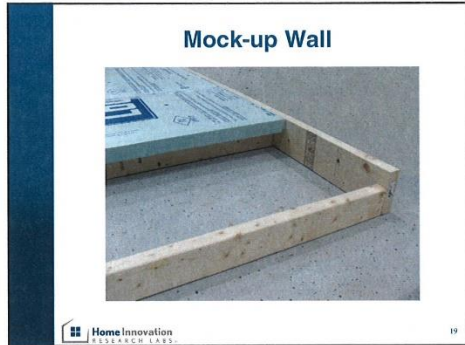

### EP&B Specs

- Framing
- Sheathing Nailing
- Outboard Insulation
- Cavity Insulation
- Claddings
- Air Sealing
- Interior

Home Innovation RESEARCH LABS 25

### EP&B Summary

- Developed for R25+ walls
- Structural sheathing on the exterior
- Foam sheathing to exterior of studs
- Window placement and drainage plane standard methods
- Rim header sufficient span most openings
- Warm Cavity

Home Innovation RESEARCH LABS 26

### EP&B Summary (cont'd)

- Same construction methodology for R25 and R30 options
- Under development
  - Siding attachment
  - OSB and plate attachment
  - Window and door installation
  - Rim header: lumber, EWP
  - Moisture management
  - Additional shear wall testing

Home Innovation RESEARCH LABS 27

### EP&B Summary (cont'd)

- Field-framed or panelized
- Standard construction details
- Durable by design

= Simplified transition from conventional framing options

Home Innovation RESEARCH LABS 28





**Home Innovation**  
RESEARCH LABS™